



Submittal Data Sheet: VRFI-09EC4-D2B(55)5

INDOOR UNIT



Job Name:		Tag #:	
Location		Date:	
Engineer:		Approval:	
Submitted to:		Unit #:	
Submitted by:		Drawing #:	
Reference		PO #:	

DC Inverter Motor

Efficiency is improved by 30% over standard PSC motors.

Ultra-Low Noise Operation

Stepless speed regulation and scientifically optimized fan wheel design enable quiet operation.

Intelligent Drainage Device

Built-in water lift condensate pump and overflow protection.

Protection Function

Water overflow, anti-freezing, temperature sensor malfunction, and fan motor overload protection.

Strong and Balanced Airflow

4-way airflow, variable fan speeds ensure consistent and comfortable circulation.

Digital Display

Users and service technicians can use the digital display on the Wall Mount Controller to see status and protection or error codes.

Thermostat Controller

By using a YMGI bridge controller, North American style thermostats (Nest, Honeywell, Pro1, YMGI etc.) can be used for temperature control, locally or remotely, individually or in groups.

ACCESSORIES

- REPLACEMENT FILTERS
- THERMOSTAT
- MOUNTING BRACKETS
- COPPER/WIRE/ACC.SET
- BRIDGE CONTROLLER

Model		VRFI-09EC4-D2B(55)5
Connection Pipes		
Liquid Connecting Pipe Diameter	in.	Ø1/4
Gas Connecting Pipe Diameter	in.	Ø1/2
Drain Pipe External Diameter	in.	Ø1
Drain Pipe Internal Diameter	in.	Ø13/16
Dimensions & Weight Indoor Unit		
Main Body (W x D x H)	in.	33 1/16 x 33 1/16 x 10 1/4
Net/Gross Weight	lbs.	58/75
Dimensions & Weight Faceplate		
Panel (W x D x H)	in.	37 3/8 x 37 3/8 x 2 1/2
Net/Gross Weight	lbs.	15/24

Model		VRFI-09EC4-D2B(55)5
Cooling Capacity	Btu/h	9500
Heating Capacity	Btu/h	10500
Power Supply	V/Ø/Hz	208/230/1/60
Power Consumption	W	59
Airflow Volume	m³/h	1000/900/750
	CFM	590/530/440
Related Current Heating/ Cooling	Amp	0.5
MCA	Amp	0.625
MOP	Amp	15
Condensate Pump Lift from base of unit	in.	19 11/16"
Sound Pressure Level (H/M/L)	dB(A)	37/35/32
Refrigerant		R410A



Submittal Data Sheet: VRFI-09EC4-D2B(55)5

INDOOR UNIT

Dimensions (inches)	
L	33 1/16"
W	33 1/16"
H	10 1/4"
L1	37 3/8"
W1	37 3/8"
H1	2 1/2"
D	26 3/4"
E	30 11/16"

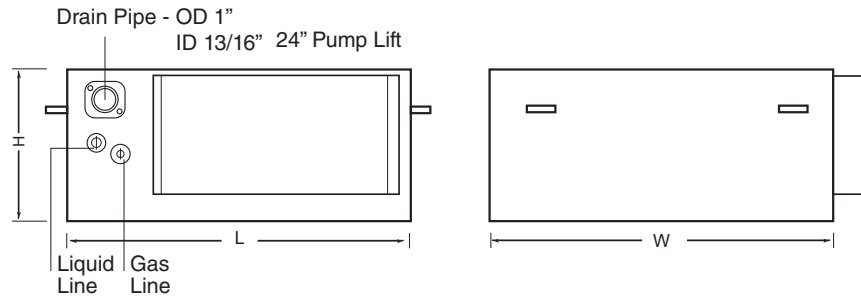
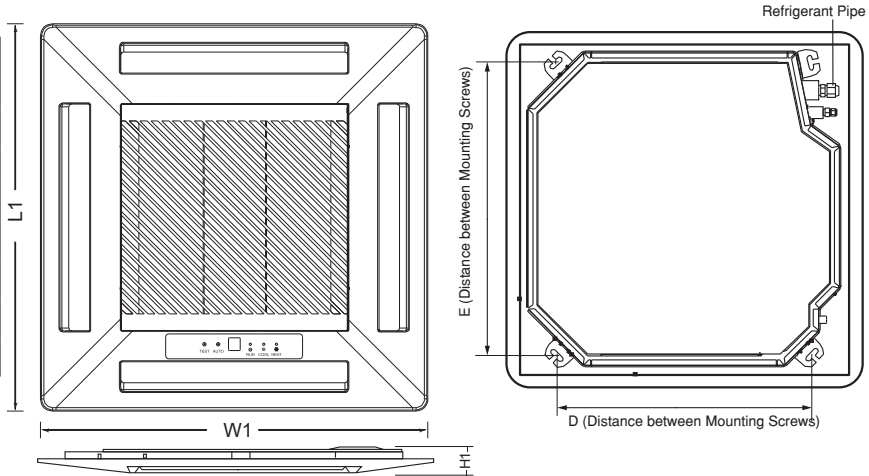

WIRING

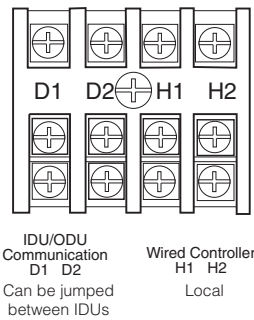
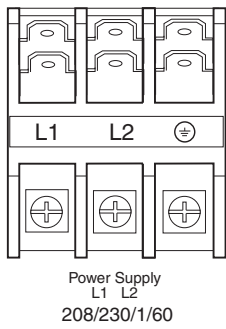

CLEARANCE

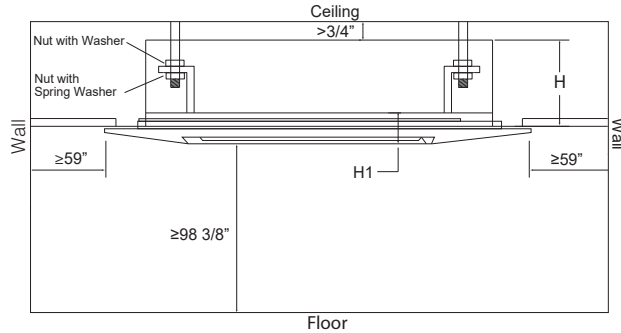

FEATURES

- 208-230/1/60 power input
- Quiet and efficient heating & cooling.
- DC Inverter technology
- Wide working ambient temperature ranges
- Built in protection functions
- Washable filter
- Unit ships pre-charged with dry nitrogen
- Stylish design
- Standard flare nut connection valves
- Built to ETL/UL/CSA/AHRI standards
- Easy installation and convenient maintenance

YMG I Group
 601 Arrow Ln, O'Fallon, Missouri 63366
 Phone: 1-866-833-3138
 Fax: 1-866-377-3355
 ymgigroup.com
 sales@ymgigroup.com

Sales Representative or Distributor: