



Submittal Data Sheet: VRFI-15EC4-D2B(55)5

INDOOR UNIT



Job Name:		Tag #:	
Location		Date:	
General Contractor:		Mechanical Contractor:	
Sales Representative:		Sales Engineer:	
Submitted by:		Drawing #:	
Reference		PO #:	

DC Inverter Motor

Efficiency is improved by 30% over standard PSC motors.

Ultra-Low Noise Operation

Stepless speed regulation and scientifically optimized fan wheel design enable quiet operation.

Intelligent Drainage Device

Built-in water lift condensate pump and overflow protection.

Protection Function

Water overflow, anti-freezing, temperature sensor malfunction, and fan motor overload protection.

Strong and Balanced Airflow

4-way airflow, variable fan speeds ensure consistent and comfortable circulation.

Digital Display

Users and service technicians can use the digital display on the Wall Mount Controller to see status and protection or error codes.

Thermostat Controller

By using a YMGI bridge controller, North American style thermostats (Nest, Honeywell, Pro1, YMGI etc.) can be used for temperature control, locally or remotely, individually or in groups.

ACCESSORIES

- REPLACEMENT FILTERS
- THERMOSTAT
- MOUNTING BRACKETS
- COPPER/WIRE/ACC.SET
- BRIDGE CONTROLLER

Model		VRFI-15EC4-D2B(55)5	
Connection Pipes			
Liquid Connecting Pipe Diameter	in.	Ø1/4	
Gas Connecting Pipe Diameter	in.	Ø3/8	
Drain Pipe External Diameter	in.	Ø1	
Drain Pipe Internal Diameter	in.	Ø13/16	
Dimensions & Weight Indoor Unit			
Main Body (W x D x H)	in.	33 1/16 x 33 1/16 x 10 1/4	
Net/Gross Weight	lbs.	58/75	
Dimensions & Weight Faceplate			
Panel (W x D x H)	in.	37 3/8 x 37 3/8 x 2 1/2	
Net/Gross Weight	lbs.	15/24	

Model	VRFI-15EC4-D2B(55)5	
Cooling Capacity	Btu/h	15000
Heating Capacity	Btu/h	17000
Power Supply	V/Ø/Hz	208/230/1/60
Power Consumption	W	59
Airflow Volume	m³/h	1000/900/750
	CFM	590/530/440
Related Current Heating/ Cooling	Amp	0.5
MCA	Amp	0.625
MOP	Amp	15
Condensate Pump Lift from base of unit	in.	19 11/16"
Sound Pressure Level (H/M/L)	dB(A)	37/35/32
Refrigerant		R410A



Submittal Data Sheet: VRFI-15EC4-D2B(55)5

INDOOR UNIT

Dimensions (inches)	
L	33 1/16"
W	33 1/16"
H	10 1/4"
L1	37 3/8"
W1	37 3/8"
H1	2 1/2"
D	26 3/4"
E	30 11/16"

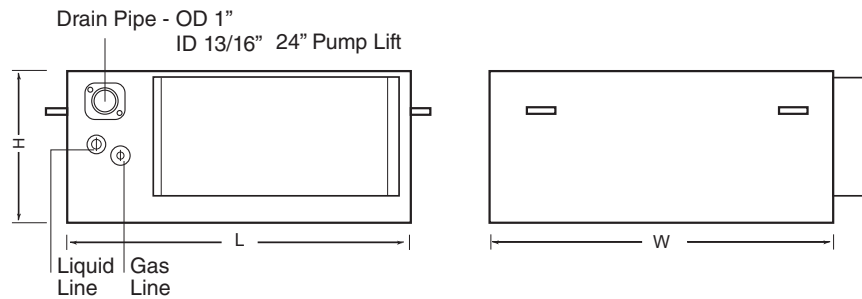
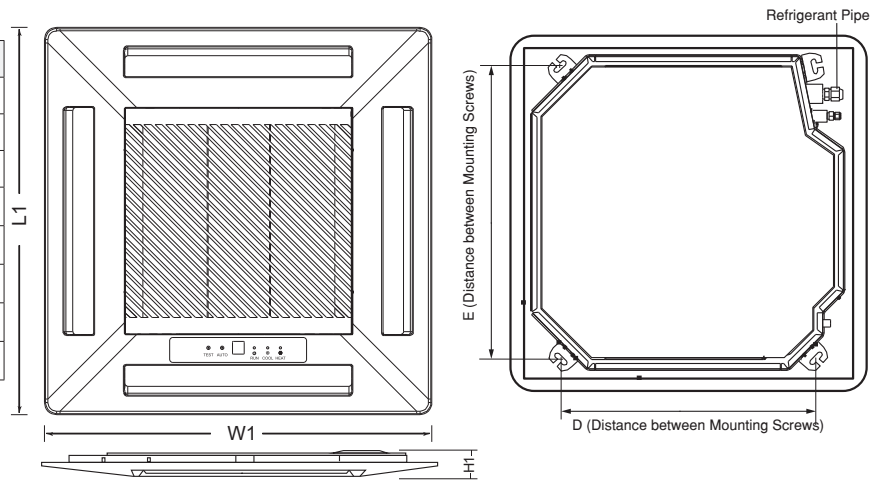

WIRING

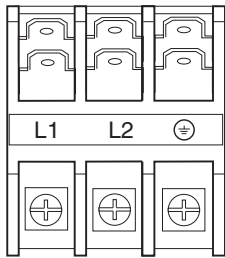

Power Supply
L1 L2
208/230/1/60

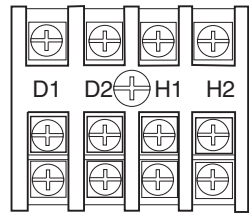

IDU/ODU Communication
D1 D2
Can be jumped between IDUs

Wired Controller
H1 H2
Local

CLEARANCE

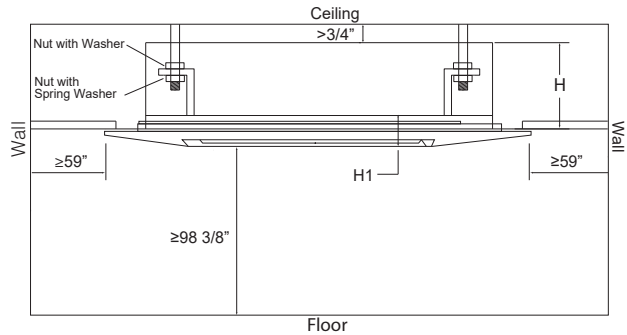

FEATURES

- 208-230/1/60 power input
- Quiet and efficient heating & cooling.
- DC Inverter technology
- Wide working ambient temperature ranges
- Built in protection functions
- Washable filter
- Unit ships pre-charged with dry nitrogen
- Stylish design
- Standard flare nut connection valves
- Built to ETL/UL/CSA/AHRI standards
- Easy installation and convenient maintenance

YMGI Group
601 Arrow Ln, O'Fallon, Missouri 63366
Phone: 1-866-833-3138
Fax: 1-866-377-3355
ymgigroup.com
sales@ymgigroup.com

Sales Representative or Distributor: