



## Submittal Data Sheet: VRFI-09EC4-C2B(55)5

### INDOOR UNIT



**VRFI-09EC4-C2B(55)5**

### ACCESSORIES

- REPLACEMENT FILTERS
- THERMOSTAT
- MOUNTING BRACKETS
- COPPER/WIRE/ACC.SET
- BRIDGE CONTROLLER

Model		VRFI-09EC4-C2B(55)5	
<b>Connection Pipes</b>			
Liquid Connecting Pipe Diameter	in.		Ø1/4
Gas Connecting Pipe Diameter	in.		Ø3/8
Drain Pipe External Diameter	in.		Ø1
Drain Pipe Internal Diameter	in.		Ø13/16
<b>Dimensions &amp; Weight Indoor Unit</b>			
Main Body (W x D x H)	in.	23 15/32 x 23 15/32 x 9 1/2	
Net/Gross Weight	lbs.		48.5 / 59.5
<b>Dimensions &amp; Weight Faceplate</b>			
Panel (W x D x H)	in.	26 3/8 x 26 3/8 x 1 31/32	
Net/Gross Weight	lbs.		8.8 / 11

Job Name:		Tag #:	
Location		Date:	
General Contractor:		Mechanical Contractor:	
Sales Representative:		Sales Engineer:	
Submitted by:		Drawing #:	
Reference		PO #:	

#### Ceiling Mount Compact Cassette EC Unit

The EC indoor unit is the perfect solution for large open rooms that are more than 25' long or wide. YMGI's Ceiling Mount Cassette Units allow for easy installation into the 24" joist space and flush mount to the ceiling. Standard remote or wall mounted thermostats are available. Each unit has an indicator that displays unit mode, and a Wall Controller with an LED display that shows unit set temperature and mode settings as well as technician information.

Model	VRFI-09EC4-C2B(55)5	
Power Supply	V/Ø/Hz	208~230 / 60 / 1
Function Type		Heat Pump
Cooling Capacity	kW	2.8
Cooling Capacity	kBtu/h	9.5
Heating Capacity	kW	3.1
Heating Capacity	kBtu/h	10.5
Air flow volume L / M / H	m3/h	400 / 500 / 600
Air flow volume L / M / H	CFM	235 / 295 / 355
Related Current Heating/ Cooling	Amp	0.5
MCA	Amp	0.625
MOP	Amp	15
Condensate Pump Lift from base of unit	in.	19 11/16"
ESP	Pa	0
Sound Pressure Level L / M / H	dB	35 / 39 / 41
Sound Power Level L / M / H	dB	45 / 49 / 51
Cross-sectional Area of Power Cable Conductor	mm2	1
Recommended Power Cable	N	3
Circuit Breaker	A	15
Fan Type		Centrifugal
Fan Quantity		1
Fan Diameter-height	inch	12 5/8 / 5 7/8
Fan Motor Model		FN35B-ZL
Fan Motor Drive Type		Direct
Fan Motor Speed	rpm	800/750/700/650/600/550
Motor Insulation Class		B
Motor Safe Class		IP40
Fan Motor Power Output	W	45
Fan Motor Running Current	A	<1
Refrigerant		R410A
Evaporator Max. Allowable Pressure	MPa	10
Connection method		Flare Connection
Cross-sectional Area of Power Cable Conductor	sq in	0.002
Fuse Current	A	15
Power Consumption	kW	0.035
Evaporator Material		Aluminum fin-copper tube
Evaporator Face Area	sq.ft	2.69
Evaporator Fin Type		hydrophilic-window
Timer		YES
Energy Saving		YES
Access Control System		Optional



# Submittal Data Sheet: VRFI-09EC4-C2B(55)5

## INDOOR UNIT

Dimensions (inches)	
L	23 15/32 "
W	23 15/32 "
H	9 1/2"
L1	26 3/8"
W1	26 3/8 "
H1	1 31/32"
D	19"
E	21 3/4"

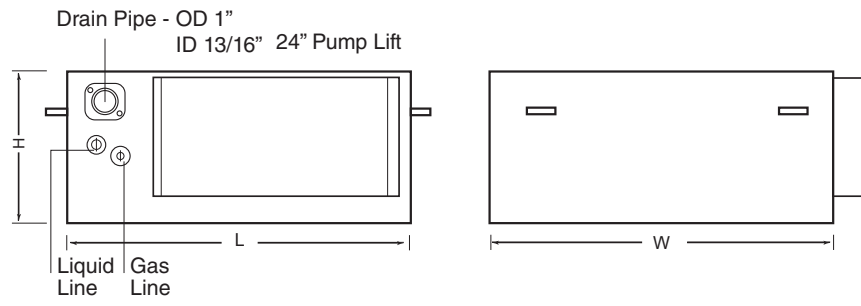
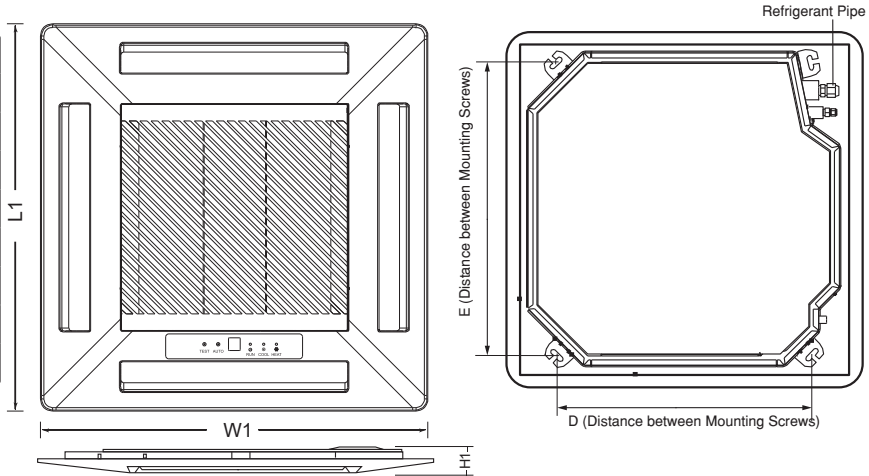

## WIRING

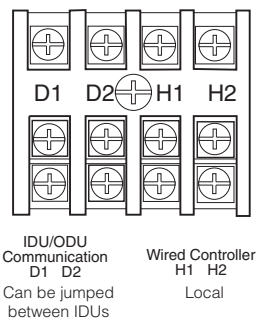
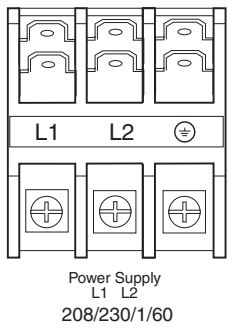

## CLEARANCE

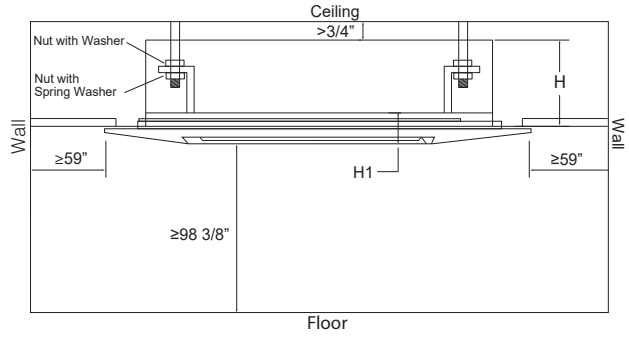

## FEATURES

- 208-230/1/60 power input
- Quiet and efficient heating & cooling.
- DC Inverter technology
- Wide working ambient temperature ranges
- Built in protection functions
- Washable filter
- Unit ships pre-charged with dry nitrogen
- Stylish design
- Standard flare nut connection valves
- Built to ETL/UL/CSA/AHRI standards
- Easy installation and convenient maintenance

**YMG I Group**  
 601 Arrow Ln, O'Fallon, Missouri 63366  
 Phone: 1-866-833-3138  
 Fax: 1-866-377-3355  
 ymgigroup.com  
 sales@ymgigroup.com

Sales Representative or Distributor: