



YMGI, Engineered Comfort Products for A Sustainable and Efficient Green World

## Installer's Instruction and User's Manual Variable Refrigerant Flow (VRF) Indoor Units - Ducted Medium/High ESP

**Models:** VRFI-18EF-M2B(55)5  
VRFI-24EF-M2B(55)5  
VRFI-30EF-M2B(55)5  
VRFI-36EF-M2B(55)5

VRFI-42EF-M2B(55)5  
VRFI-48EF-M2B(55)5  
VRFI-72EF-H2B(55)5  
VRFI-96EF-H2B(55)5



Thank you for choosing this YMGI product. Please read the user's manual carefully before installation/operation and retain for your records and future reference. If you need a replacement copy, please contact your local agent or visit [www.ymgigroup.com](http://www.ymgigroup.com) to download a current electronic version.

### NOTICE

This product is designed and manufactured to be free from any defects in material and workmanship during normal use and maintenance. Installation, operation, maintenance and repair must follow all standards and professional practices for regular cooling and heating equipment, such as NEC, State, or Local Codes and all related documents/manuals provided by YMGI. Failure to follow and adhere to all codes and documentation can cause damage to equipment, property even personal injury.

**Installer:** Currently licensed/certified HVAC technicians only. Must Read the manual and all provided documents prior to installation. Complete and fill out all required information on the warranty registration card.

**User:** Retain this manual and all supplied documents for your records and future reference.

**Service:** Use this manual for information concerning servicing and maintenance of this product.

### SAFETY WARNING

Only qualified technicians should install and service this equipment. The installation, startup, operation and servicing of this equipment can be hazardous and requires a HVAC professional who has been trained, licensed and certified. Installations, adjustments or any equipment alterations done by an unqualified person could result in serious injury and even death. When working on the equipment, observe all precautions in the provided documents, on the tags, stickers, and labels that are attached to or placed on the equipment.

# Table of Contents

<b>Introduction</b> .....	<b>3</b>
Important Environmental Concerns .....	3
Responsible Refrigerant Practices .....	3
Disposal Notice .....	3
Proper Field Wiring .....	3
Personal Protective Equipment .....	3
Copyright .....	3
Basic Cautions and Warnings .....	4
Note From YMGI .....	4
Installing Technician/Contractor's Responsibilities .....	7
<b>Section 1</b> .....	<b>8</b>
Limited Product Warranty .....	8
Why Require Professional Installation .....	11
Suggestions on Hiring a HVAC Professional .....	11
Safety Precautions .....	9
<b>Section 2</b> .....	<b>13</b>
Preparing for Installation .....	13
Standard Fittings .....	13
Accessories .....	14
Location Considerations .....	14
Unit Dimensions .....	15
Service Clearances .....	16
Related Working Condition .....	17
<b>Section 3</b> .....	<b>17</b>
Installation Instructions .....	17
Installation of the Indoor Unit .....	17
Mounting the Unit .....	17
Refrigerant Pipe Connections .....	19
Pipe Flaring .....	19
Installation of Drainage for Indoor Unit .....	20
Drainage Installation .....	20
Testing Drainage System .....	22
Installation of Air Ducts .....	22
<b>Section 4</b> .....	<b>25</b>
Wiring the Unit .....	25
Wiring Power Requirements .....	26
Power Cord Connection .....	28
Communication Wire Between Units .....	28
Illuminated Connection .....	29
<b>Section 5</b> .....	<b>31</b>
Routine Maintenance .....	31
Cleaning Filters .....	31
Maintenance Before Seasonal Use .....	31
Maintenance After Seasonal Use .....	31
<b>Section 6</b> .....	<b>32</b>
Error Codes for the Indoor Unit .....	32
<b>Section 7</b> .....	<b>33</b>
Troubleshooting .....	33
<b>Section 8</b> .....	<b>34</b>
Wall Mount Control .....	34
<b>Section 9</b> .....	<b>35</b>
Operating Tips .....	35
<b>Section 10</b> .....	<b>35</b>
Customer Service and Technical Support .....	35

## Introduction

Read this manual carefully, making sure you understand all the instructions, practices and procedures contained in this manual. Be sure you are familiar with all the safety advisories that appear throughout this manual. Your personal safety depends upon your observance of all precautions contained in this manual.

The 3 types of advisories are defined in the following table:

<b>⚠ WARNING</b>	Indicates a potentially hazardous situation which, if not avoided, could result in serious injury or even death.
<b>⚠ CAUTION</b>	Indicates a potentially hazardous situation which, if not avoided, could result in minor or moderate injury. It is also used to alert against unsafe practices.
<b>NOTICE</b>	Indicates a situation that could result in equipment or property-damage only. It can also be used to call attention to important details within this manual.

## Important Environmental Concerns

Studies have shown that certain man-made chemicals can affect the earth's stratospheric ozone layer when released into the atmosphere. Refrigerants that contain Chlorine, Fluorine and Carbon (CFCs) and those containing Hydrogen, Chlorine, Fluorine and Carbon (HCFCs), may affect the ozone layer. Not all refrigerants have the same potential impact on the environment. YMGI Group advocates for the responsible handling of all refrigerants including industry replacements for CFCs such as HCFCs and HFCs.

## Responsible Refrigerant Practices

YMGI Group believes that responsible refrigerant practices are important to our customers, the HVAC/R industry and the environment. All HVAC/R technicians who handle refrigerants must be certified. The Federal Clean Air Act (Section 608) sets forth the requirements for handling, reclaiming, recovering and recycling of certain refrigerants, the equipment and tools necessary to perform these service procedures. In addition, some states or municipalities may have additional requirements that must also be adhered to for responsible management of refrigerants. HVAC/R technicians must know the applicable laws and follow them.

## Disposal Notice

Do not dispose of this product or its components as unsorted municipal waste, as they contain items that may require special treatment. Contact your local waste management company for details.

### **⚠ WARNING**

#### **Proper Field Wiring and Grounding Required!**

Failure to follow established electrical codes can result in death, serious personal injury and property damage. All field wiring **MUST** be performed by qualified personnel, such as a currently licensed electrician. Improperly installed and grounded field wiring poses **FIRE** and **ELECTROCUTION** hazards. To avoid these hazards, you **MUST** follow the requirements for field wiring installation and grounding as described in this manual, by NEC and your state/local electrical codes.

### **⚠ WARNING**

#### **Personal Protective Equipment (PPE) Required!**

Failure to wear proper PPE for the job being undertaken could result in serious injury or even death. Technicians must take the necessary precautions to protect themselves from potential electrical, mechanical, and chemical hazards and **MUST** follow all precautions in this manual and on the tags, stickers, and labels, as well as the instructions below:

- Before installing or servicing this unit, technicians **MUST** put on all PPE recommended for the work being undertaken. **ALWAYS** refer to appropriate Material Safety Data Sheets (MSDS) and Occupational Safety and Health Administration (OSHA) guidelines for proper PPE.
- When working with or around hazardous chemicals, **ALWAYS** refer to the appropriate MSDS sheets and OSHA guidelines for information on allowable personal exposure levels, proper respiratory protection, and handling recommendations.

If there is a risk of arc or flash, technicians **MUST** put on all PPE in accordance with NFPA 70E or other country-specific requirements for arc flash protection, **PRIOR** to servicing the unit.

## Copyright

This document and the information contained therein are the sole property of YMGI Group and shall not be used or reproduced in whole or in part, without the written permission of YMGI Group. YMGI Group reserves the right

to revise this manual at any time and to make changes to its content without obligation to notify anyone about any modifications, revisions or changes.

### **⚠ WARNING**

- Instructions for installation and use of this product are provided by the manufacturer.
- Installation must be performed by authorized and licensed personnel only and in accordance with all the requirements of this manual, the NEC, CEC and any state/local codes.
- For safe operation of this unit, please read and follow all instructions carefully.
- The total operation capacity of the indoor units should not exceed 120% of the total capacity of the outdoor units if all indoor units must operate at their peak capacities all the time. Otherwise, the heating and cooling operation will be diminished and less efficient which could damage the units.
- Any person responsible for system operation or system maintenance should retain this manual for reference.
- If the unit fails to operate normally, please contact your authorized system installer or HVAC professional as soon as possible and provide the following information:
  - Data on the unit (model number, serial number and owner's name).
  - A detailed description of the unit's problem before and after the problem occurred.
- To avoid personal injury or property damage, do not disassemble the unit yourself. If disassembly is required to check the unit, contact your authorized system installer or HVAC professional as they have the experience and training necessary to perform this task.

**Note:** Each unit has been thoroughly tested to ensure it operates correctly before leaving the factory.

### **Basic Cautions and Warnings**

#### **⚠ CAUTION**

All units shall be installed by an experienced HVAC licensed contractor or technician. Read all manuals before installation, startup and operation.

#### **⚠ CAUTION**

All NEC, state, local codes and installation instructions must be followed for all units, otherwise, the unit warranty will be void and could result in serious damage to people or property.

#### **⚠ WARNING**

YMGI Group is not responsible for any damage or loss due to Do-It-Yourself(DIY), self-installation or any improper installation, operation, service or natural disasters of any kind.

#### **⚠ WARNING**

Do not connect power to the unit until all wiring, tubing and all unit inspections and tests have been completed. Ground the unit according to the instructions and adhering to NEC, state and local codes.

#### **⚠ WARNING**

All wiring connections must be correct and secure. Loose wire(s) or improper contacts may cause arcs or overheating which can result in a fire hazard.

## Note From YMGI – **Must Read**

Dear Customers, Installers, and Contractors

Thank you for choosing a YMGI product.

All YMGI's products are fully tested and have passed rigorous safety, performance and manufacturing standards before being packed and shipped. YMGI only uses suppliers that meet our strict standards for high quality and performance for all parts. YMGI also recognizes a quality installation is equally important therefore your system must be installed by a licensed HVAC professional. A quality installation ensures your unit will operate at its highest efficiency and peak performance for many years of worry free comfort; while a poor installation can result in unit failure and cause the unit to operate inefficiently, either immediately or over time, resulting in costly repairs.

Because a quality installation is so critical, YMGI provides detailed information in our manuals which will aid the installing technician and the owner of the unit(s).

At YMGI our goal is to ensure that your YMGI units are installed properly and correctly from the beginning.

The YMGI equipment you purchased is either a split-type or a self-contained cooling/heating system. These types of systems require a certified and licensed HVAC professional technician for proper installation. Only a certified and licensed HVAC professional technician will have the knowledge, experience, and attention for all required details to perform a complete and successful installation. This equipment is different from a window or portable type air conditioners you can purchase from local big box and retail stores which the manufacturer may not require certified and licensed personnel to install.

Reading and following YMGI Group recommendations and requirements contained in the following pages and other documents, is the first step to help ensure a smooth installation and proper operation of your unit for many years.

### **⚠WARNING**

YMGI does not recommend nor allow any Do-It-Yourself (DIY) installation (partially or fully). Due to the complexity of the installation of this product most DIY installations usually have problems, either immediate or in the near future. These problems can cost more to fix than any upfront savings. **YMGI warranty does not cover any DIY units.**

If you have any questions about your unit or if the unit has a problem, you should first check the manual. If you can't find a solution, then contact your local installer or service technician to schedule a service appointment. The technician can physically inspect the unit. If at the time of inspection, the installer or service technician has any questions about the unit, they can contact YMGI technical support division directly at:

**Toll Free Number: (866)833-3138 or Email: [techsp@ymgigroup.com](mailto:techsp@ymgigroup.com)**

## **IMPORTANT: YMGI Group is the MEDIA AUTHORITY:**

YMGI Group, located in O'Fallon, MO 63366 is the author of all media produced for its products and is the only party able to give any additional explanation for any data, definitions and or descriptions found within any of its media, including but not limited to YMGI product brochures, manuals, pamphlets, catalogs, and videos. YMGI's distributors, installers, dealers, agents, customers or any other third parties will not supersede YMGI in anyway concerning YMGI-published materials and their meaning. Any concerns or questions arising from YMGI distributors, installers, dealers, agents, customers or any other third parties, should be presented directly to YMGI. YMGI will respond to any concerns or questions, if necessary, about any of its media in writing.

## **NOTICE**

- Be sure to only hire a certified and currently licensed HVAC Company to complete 100% of the installation so that all details of the installation are performed correctly and completely.
- Factory Warranty will be void if any portion of the installation is not performed by a licensed HVAC contractor/technician. DIY or partial DIY will also void ALL factory warranties.
- Hiring an HVAC technician that is offering their services as a "side job" rather than a licensed HVAC company may pose possible risk. This may result in an incomplete or unsatisfactory installation, no guarantee for workmanship, maintenance or further service to your unit.
- Have the installation technician read in full the installation manual and all supplied documents for the product model you purchased. Details within the provided documentation contributes greatly to the success and quality of the installation. Experience with other manufacturers may not be applied fully to another manufacturer, although there will be similarities there will also be differences. Ignoring the provided installation procedures is an act of negligence and may cause unit failure or damage which could be permanent.
- It is possible for a licensed contractor/technician to make a mistake during the installation. YMGI does not supervise nor is able to control the contractor/technician's installation. It is critical that the installer take each variable into account during the initial installation. This will ensure a complete and professional installation and that all units work properly.

## **⚠WARNING**

**The following will damage the unit and its key components resulting in loss of factory warranty:**

1. Any foreign substances introduced into the system because of failure to seal the ends of the refrigeration piping before pulling the piping through any structures at time of installation.
2. Not installing an oil P-trap in the copper suction line where the indoor unit is located 18 feet or more below the outdoor unit.
3. Cross piping and/or cross wiring of any units including more than one single zone or a multi zone system.
4. Not conducting a positive leak check by charging the system with dry-nitrogen and performing soap bubble testing.
5. Not conducting a negative leak check by evacuating the copper lines for 30 minutes. The vacuum must be held at 500 microns or better for at least 5 minutes, starting a 5-minute timer after the vacuum pump is turned off.
6. Not conducting a positive leak check prior to the negative leak check.
7. Not selecting the correct size wire or circuit breaker.
8. Not answering ALL questions in the technician's checklist located inside the warranty registration form.

## **⚠WARNING**

**The following may be overlooked, ignored, or considered unimportant during your installer's installation, but will cause your unit to underperform and may cause unit failure.**

1. Any kinks in or improper bending of the copper piping.
2. Any poorly formed flares, not centering the flare with the flare nut, or not tightening all connections.
3. Not trial testing each indoor unit individually.
4. Not reading technical data (temp/time/pressure/current) after the system is stabilized (normally the compressor needs to run at least 10 minutes before reading the data). If the data is read too early, it may lead to inaccurate assessments about the unit.

In an effort to help protect our customers from possible faulty installations that can lead to premature unit failure, YMGI provides the above information for you (the owner) and the technician. You can observe while your system is being installed, even though your observation is not a guarantee your system is being or has been installed properly and professionally. With the information provided above, you will know some things to look for and questions you can ask. If at any time you feel there may be an issue with the installation, please have your technician contact YMGI at (866)833-3138 x 703 with any questions, issues or concerns you may have.

## **INSTALLING TECHNICIAN/CONTRACTOR'S RESPONSIBILITIES**

1. Discuss with the customer detailed information about the structure to be conditioned, local weather (typical design, extreme temperature/humidity conditions, cooling and heating hours), previous and existing HVAC equipment (if any), usage and dependence on new HVAC equipment or YMGI products.
2. Performing a cooling/heating load calculation by using commercially available professional programs/methods such as Right-J (Manual J) for residential HVAC applications and Right-CommLoad (ASHRAE RTS/CLTD) for light commercial and commercial HVAC applications.
3. Contact your YMGI distributor/sales department or contact YMGI directly to obtain additional information to fully understand your YMGI products, including but not limited to product features, cooling/heating performance at standard ratings/conditions and extreme conditions, allowed indoor and outdoor temperature and humidity ranges, installation, operation, maintenance, service, warranty, parts and any other issues pertaining to YMGI products.
4. Select the correct (most suitable) YMGI product unit models and accessories necessary for your HVAC applications and list them in the proposal/quote, in writing, on company's quotation form or letter head, based upon the information you collected from 1, 2 and 3 listed above.
5. List your currently valid HVAC license number and EPA number in your proposal/quote.
6. Make sure you are the only party to perform the entire installation and you will not sub-contract any part of the installation to any non-licensed parties or persons. You will be solely responsible for the entire installation that you have been contracted.
7. Make sure you have all the materials you need to properly, completely and correctly finish the installation. The YMGI units and accessories may be just a portion of what you will need for the project. When support issues arise, remember YMGI employees and YMGI distributors/sales, dealers and agents are not installers and may only provide suggestions. You are the only one qualified to determine what other materials you need to complete the installation.
8. When connecting electrical wires, follow all NEC, state and local codes and ensure the installation of all YMGI units and accessories meet these requirements.
9. Connect the unit to a correctly sized electrical power source. If the unit is installed in an area where lightning or storms occur frequently, a correctly sized and type of power surge protector must be installed between the outdoor unit and the power source.
10. Select the correct types and sizes of HVAC circuit breakers, disconnect switch boxes, wires and conduit from circuit breaker to disconnect box and then from disconnect box to outdoor unit.
11. Select the proper location for installing indoor units and outdoor units with all factory requirements being followed (cooling/heating air inlets and outlets are not blocked, or restricted, mounting structure is secure, installation for convenience is considered, allow adequate clearance for maintenance/service and all applicable codes are met).
12. Cap/tape the two ends of every copper line before running them through any structure to keep any foreign substances from entering the copper line causing contamination. Label the copper lines A-A, B-B, C-C, D-D, or any other identifying marks on each pair of copper lines and wiring cable sets to keep from cross-piping or cross-wiring in multiple zone installations or where pipes for different single zone systems are close to one another.
13. Secure the wiring cables that connect between the indoor unit and outdoor unit, following all applicable NEC, state and local codes for your installation. If there are no special NEC, state or local codes to govern how these wires are to be installed, you can tape/cable tie them along with insulated copper line.
14. Tighten all pipe and wire connections ensuring there is no leakage or false/loose connections.
15. Conduct a positive pressure leakage test, checking each of the inter-connecting copper lines between each indoor unit and outdoor unit by charging with dry-nitrogen at the outdoor unit's service port (**NOTE: do not back-seat stopping valve**). A liquid soap solution shall be applied at all pipe connections to check for leakage. A 1/4" - 5/16" hose/valve adaptor may be needed if you have a 1/4" traditional manifold hose connection.
16. If there is no positive leaking, then conduct a negative pressure leakage test, checking all inter-connecting copper lines between each indoor unit and outdoor unit by pulling vacuum at the outdoor unit's service port (**NOTE: do not back-seat stopping valve**) and checking that a vacuum level of 500 Microns can be held for at least 20 minutes.
17. If there is no leakage found at any of the refrigeration pipe connections, flip up the indoor unit's face panel and remove its filter, carefully pour some clear water onto the up-right aluminum coil surface to test if the water can drain freely out of each of the indoor unit's without finding any leakage.
18. If there is water leakage found, locate the source of the leak and correct it. Only after everything is clear and all the necessary inspections made, engage the correct electrical power to the system.

19. Then back-seat stopping valves of the outdoor unit to release refrigerant from the outdoor unit into the inter-connecting pipes and the indoor unit.
20. Make sure both the indoor unit and outdoor unit are powered on correctly, operating the indoor unit in fan mode first. Then move on to test cooling, dehumidifying/drying, heating and other modes.
21. Read refrigerant pressures and pipe/valve temperatures only after the system is stabilized (normally 10 minutes after cooling/heating mode is started successfully). Record this data into the technician checklist in the lower half section of the Limited Product Warranty Registration Card/Form.
22. Adjust refrigerant charging level (remove refrigerant if pipe is shorter, the temperature is colder; add refrigerant if pipe is longer the temperature is warmer), following the manufacturer's instructions. If the average pipe length is shorter or longer than 25' and pressure/temperature readings at the outdoor unit service valves are not falling into normal ranges.
23. Explain to the user/owner about proper unit operation and maintenance. Leave your contact information to allow them to reach you. If the customer finds the unit does not work properly and cannot resolve the issue themselves, check the customer's units/parts/accessories and correct the issue if there is one. Communicate with YMGI-technical support line at (866)833-3138 x 703, if further help is necessary.

Following these requirements will aid in ensuring that the units to be installed meet general HVAC practicing standards and necessary factory requirements. Finding any possible problems early and preventing any further damage to the unit will help to ensure a properly working unit for many years.



## LIMITED PRODUCT WARRANTY

Once the installation and successful testing of the system has been completely performed by a qualified licensed/certified HVAC technician/contractor, the registration card/form is filled out completely and correctly, mailed and filed along with a valid installation invoice from the contractor within 7 days of the original installation, the following standard **Limited Product Warranty** is qualified: **10-years** on the **compressor** and **5-year** on **PARTS ONLY**. There is **no labor coverage**.

YMGI products are designed and manufactured free from defects in workmanship, and materials for normal use. However, if for any reason, including occasionally transporting between YMGI factories/warehouses and your delivery location, you discover the unit has issues, YMGI Group will help field a solution by following YMGI's established warranty procedures:

**Compressor:** YMGI will warrant the compressor of a YMGI-validated and approved warranty filing, for a period of 10 years from the date of successful installation at its original installation location.

**Parts:** YMGI will warrant parts of a YMGI-validated and approved warranty filing, for 5 years from the date of successful installation at original installation location.

All warranty compressors and parts replaced will become the sole property of YMGI Group and must be returned upon request. Warranty parts may be new or refurbished. All parts are tested and approved before shipping.

**At no time does YMGI Group warrant labor cost of any type. Warranty will start from the date of a successful installation at the original installation location, or 90 days as of original shipping date from YMGI Group, whichever comes first.**

***This is a standard limited liability warranty and DOES NOT cover the following:***

- Any damage or repairs to properties, or persons as an incident of or consequence of improper faulty transportation, installation, operation, maintenance or service.
- Any damage caused by frozen or broken water hoses or refrigeration pipes in the event of equipment failure.
- Any damage due to floods, fire, wind, lightening, accidents, corrosive atmosphere.
- Any damage due to interruption or inadequate electrical service to equipment.
- Any products that are installed outside the US or Canada.
- Any unit that has been moved from its original installation address.
- Any labor costs associated with the installation or service of the unit.
- Poor unit performance due to improper unit selection (SEER, Unit size).

**To validate the above warranties, ALL of the following conditions must all be fulfilled:**

1. The unit was fully (100%) and successfully installed by a licensed or certified HVAC technician.
2. The unit was installed following all NEC, state and local codes.
3. The unit was installed following all the information within the Instructions and User Manuals provided by YMGI Group.
4. ALL fields, especially the technician-checklist, of the **Limited Warranty Registration Card/Form** were filled out completely by the installing technician and signed by both the installing company's technician and the unit owner.
5. The **Limited Warranty Registration Card/Form** and a copy of the original installing company's invoice have been received by YMGI Group-Warranty Dept., POB 1559, O'Fallon, MO 63366, within 7 days of successful installation.

**No warranty filing will be validated or approved, if any one of the above conditions are not met.  
Product registration does not guarantee the validity of this limited warranty statement.**

## Steps to follow for warranty part replacement:

1. The installing or service technician must contact YMGI tech support at 1-866-833-3138 ext. 703 from the installation location to check and confirm with YMGI Technical support the exact part(s) needed to fix the problem(s).
2. YMGI will check the customer's warranty filing. There will be no charge for Parts with a validated and approved warranty. Any Parts needed for warranties that have not been validated and approved or have an invalid warranty filing (resulting in an unapproved warranty request), will be charged accordingly.
3. ***YMGI will ground ship the parts ASAP. Expedited shipping is available at the customer's expense.***
4. Replacement parts that have an approved warranty registration are to be warranted for the remainder of the 5-year on parts and a 10-year compressor warranty. Purchasing of replacement parts without a valid warranty filing or unapproved warranty request, will be sold as is and are not covered by any warranty.

YMGI is continually improving products with various engineering changes and these changes are made without prior notice. Such improvements or changes include but are not limited to product specification, appearance, functionality, size, packaging, etc. These improvements or changes will not void the limited warranty stated herein. YMGI is the final authority concerning this warranty policy.



**YMGI GROUP**  
Innovative, Competitive, Efficient & Convenient

# LIMITED PRODUCT WARRANTY REGISTRATION CARD / FORM

YMGI to Fill Top Portion, at Shipping, and Keep Copy A; Center Copy B for Installer to Fill and Mail back to YMGI; Bottom Copy C for Customer to Fill and Keep

<b>For YMGI Use Only</b>	The Company the Unit Was Sold Through: _____	Shipping/Packing List Number: _____	Registration Card Serial No. _____
	Did the Company Pay to YMGI: _____	HVAC Contractor/Technician—Name _____	Date the Filled Registration Card YMGI Received: _____
	Installation Invoice Attached to the Registration Card _____	Hired YMGI-Recommended HVAC Contractor/Technician? _____	Unit(s) Work Successfully (Yes/No): _____

Outdoor Serial Number (One Outdoor Unit, One Registration Card/Form):	Indoor Serial Number For Multi-Zone Units	Unit #1 _____	Unit #5 _____
		Unit #2 _____	Unit #6 _____
		Unit #3 _____	Unit #7 _____
		Unit #4 _____	Unit #8 _____

**Contact Where the Units are Installed:**  
 Name: \_\_\_\_\_ Phone: \_\_\_\_\_ Fax: \_\_\_\_\_  
 Address: \_\_\_\_\_ Email: \_\_\_\_\_  
 City: \_\_\_\_\_ State (Province): \_\_\_\_\_ Country: \_\_\_\_\_

<b>Contact of the Installing HVAC Contractor/Technician:</b> Technician Full Name (Print): _____ HVAC Technician's Company Name: _____ Address: _____ Currently Licensed or Certified HVAC Technician License or Certification Number: _____ Official Phone # to Check the License Validity: _____	<b>YMGI-Recommended Contractor/Technician:</b> Phone/Fax: _____ Email: _____ City/State (Province): _____ License Approved or Certified by: _____
---	---

**List for Installing HVAC Technician to Double Check Installation Quality, and Warranty Processing Purpose (if not filled by technician, or not filled fully, warranty will void)**

1) Are you the only one to install whole system? If not, % of installation done by you (HVAC technician).	2) What had been done, prior to your arrival?
3) Did you read the User Manual and Installation Instruction, before you started the installation?	4) Who unpacked the unit and accessory boxes to check for damage?
5) Supply electrical power W/Ph/Hz measured at wiring terminal block of indoor unit: _____ outdoor unit: _____	6) Incoming electrical power W/Ph/Hz measured at terminal blocks of indoor unit: _____ outdoor unit: _____
7) Wire gauge, length and terminal colors between circuit breaker/disconnect switch to outdoor unit:	8) Wire gauge, length and terminal colors between each indoor and outdoor unit: Unit A _____ Unit B _____ Unit C _____ Unit D...
9) The size of HVAC circuit breaker/fuse or disconnect switch to the outdoor unit:	10) Are the inter-connecting wires and copper lines between indoor and outdoor units installed/covered/protected by line set covers, or anything else?
11) What is the refrigerant pipe length between each indoor unit and the outdoor unit? Unit A _____ Unit B _____ Unit C _____ Unit D...	12) Where is/are the indoor unit(s) located? Unit A _____ Unit B _____ Unit C _____ Unit D...
13) What is the elevation difference between each indoor unit and the outdoor unit? Unit A _____ Unit B _____ Unit C _____ Unit D... (indoor unit above outdoor unit +, below -)	14) Did you check the indoor unit for condensate leakage and refrigerant leakage, before and after connecting them?
15) Where is the outdoor unit located? Ground wall balcony roof other _____ Is the outdoor unit anchored to ground or secured onto wall bracket? _____	16) Have you checked to make sure there is no cross-piping and no cross-wiring between any two indoor units (zones)? How did you do it, who was with you?
17) Were the refrigerant pipe ends capped or taped seal, prior to running them through structures to keep debris from entering the copper lines?	18) Have you checked and run cooling or heating, one unit by one unit, all working fine?
19) Did you charge the inter-connection copper pipes and indoor unit with nitrogen to check for positive leakage (pressures 150-200PSI), before conducting vacuuming leakage check?	20) Did you vacuum correctly to check the connecting pipes and indoor unit for leakage, what was the micron gauge reading, for how many minutes?
21) Did you check if the compressor can be started and stopped in a correct (design) manner?	22) If copper length were not made to the supplied or recommended refrigerant pipe length, how much refrigerant added or deducted?
23) Measured refrigerant pressures at outdoor service suction valve, when unit was at _____ Heat pump (PSI): _____ Cooling (PSI): _____ Outdoor Ambient Temp. (°F): _____	24) What were the measured temperatures (probe not touching any metal): At cooling: indoor return air °F, discharge air °F, and outdoor °F At heating: indoor return air °F, discharge air °F, and outdoor °F
25) Have you checked all unit functions, with customer's witness, and all functions are correct?	26) Did you show the user how to operate the unit? Did he/she understand you?
27) Do you provide regular one-year free technical service for this installation?	28) Do you list the working details in the invoice and leave a copy to the customer?

Installation Finished and Unit Works Successfully. Print Name of Installation HVAC Technician: _____ Signature: _____ Date and time: _____	Installation Finished and Unit Works Successfully. Print Name of Owner: _____ Signature: _____ Date and time: _____
---	--

By signing above, I acknowledge the liability and responsibility for any false statement or not telling all the facts, and I authorize YMGI to check the details of the filed above, and make its decision on warranty. I understand our filing or filing the warranty card/form DOES NOT mean automatic warranty approval, because warranty is approved only to those qualified and successful installations by qualified HVAC technician. I know the warranty, if approved, is a standard 5-year compressor and 1-year other parts only, without any labor coverage. I agree to and will follow all the contents contained in the Limited Product Warranty Policy that YMGI, not other entity, stated in public, including but not limited to manuals, web site, email, etc.

Important Note: A copy of the installing HVAC company's invoice to show all their work details, your payment proof, center copy B of this registration card filed after a successful installation, all three (3) MUST be mailed together to Warranty Dept., YMGI Group, POB 1559, OFallon, MO 63366, for warranty processing. Customer keeps bottom copy C. YMGI will check against copy A that was kept at YMGI.

## WHY DOES YMGI GROUP REQUIRE INSTALLATION AND SERVICE TO BE PERFORMED 100% BY CURRENTLY LICENSED OR CERTIFIED HVAC TECHNICIANS/CONTRACTORS?

### 1. **Expertise and Safety:**

They have the training and experience to accurately and safely install and service your equipment. The equipment runs with high-pressure refrigerant, oil and electrical current. The copper lines must be installed properly to prevent leakage and foreign substances from contaminating the refrigerant system.

### 2. **You will save money in the long run:**

If any problem occurs with the unit that has been fully installed by a currently licensed or certified technician/contractor, contact the original licensed or certified HVAC technician to evaluate the unit as they have the training and experience to correct the problem quickly and efficiently. A technician may be unwilling to repair an issue on a unit that they did not install. If you do find a technician willing to perform this service, there is an increased possibility of higher service fees, increased service visits, or delayed service from that technician.

### 3. **It's the law!**

The federal, state and/or local government and authorities have various governing laws or regulations, guidelines, ordinances, etc. These laws may require only licensed or certified professionals can install and service this type of high pressure HVAC equipment.

## SUGGESTIONS TO AID YOU IN HIRING AN HVAC CONTRACTOR:

1. Hire a currently practicing, licensed/certified HVAC professional technician/contractor. Technicians, who are no longer practicing (retired, etc.) in this field, may not have current technical knowledge or may lack experience on the equipment you have purchased.
2. Hiring a licensed technician to install your unit as a "side job" rather than a licensed HVAC company may pose possible risk. This may result in an incomplete or unsatisfactory installation, no guarantee for workmanship and lack of maintenance and further service to your unit.
3. Hire a technician/contractor who services customers in your local area and one you are familiar with. Local contractors have a faster response time and it will be easier for you to determine if they are reputable.
4. Use only a reputable licensed/certified HVAC installation professional to prevent any unexpected charges because of unethical business practices.
5. Check their references, verify they provide professional service for their customers. N.A.T.E or A.C.C.A certified technicians are strongly recommended.
6. Some contractors/technicians may not feel comfortable installing equipment that has been purchased by someone other than themselves. You can contact YMGI directly to check and see if there are contractors in your area who have installed our products or any similar products.
7. Ask for a detailed quote for the complete installation project. A flat rate quote is the safest contract for both you and the contractor.
8. Local HVAC technicians may charge you on a project basis or on an hourly basis. It has been our general experience; **a full single head installation normally can cost \$800 to \$1500**. These costs are estimates, and your actual costs may differ due to your specific job requirements and installation location.
9. Number of hours can vary depending upon each individual situation, some factors are, but not limited to:
  - Difficulty or complexity of securely installing the indoor unit.
  - Difficulty or length of the inter-connecting pipes and wires to be installed.
10. A successful installation is dependent on all these suggestions and necessary steps are followed.
11. If the contractor(s)/technician(s) are experienced with the systems/brands you purchased. **You might save on the installation cost but remember to always ask for and verify references.**
12. The contracts should list and detail all work to be performed and the standards they will follow. Some contractors are willing to include a 1-year installation/service warranty at no extra charge. Check to see if this is an available option. If available, make sure it is included in the contract.
13. Verify and confirm the installation is completed and all the unit functions have been tested and working properly. All items on the checklist should be checked and clearly marked in the warranty registration card/form, prior to paying the contractor in full.

The cost of not having your unit professionally installed can be more expensive than the additional cost of hiring a certified contractor. Protect your investment and warranty eligibility by doing it right the first time.

## **▲WARNING**

### Safety Precautions

1. Follow these instructions to complete the necessary installation progress. Carefully read this manual before installation and unit startup or servicing.
2. Wire size of power cord should be properly sized to meet the required electrical loads. Should the power cord get damaged, the power cord should be replaced with a manufacturer approved cable.
3. After connecting the power cord, attach the electric box cover and secure properly.
4. Always meet the nitrogen charge requirements when welding pipes.
5. Never short-circuit or cancel the pressure switch as this will result in damage to the unit.
6. Connect the wired controller before energizing, otherwise the wired controller cannot be used.
7. Before using the unit, verify the piping and wiring are correct. This will avoid water leakage, refrigerant leakage, electric shock, fire, etc.
8. Do not insert fingers or objects into the air outlet or inlet grille.
9. Open a door or window for ventilation for allowing fresh air to enter the room to avoid depleting the oxygen while gas/oil supplied heating equipment is used during the installation.
10. Never start up or shut off the unit by means of directly plugging into or unplugging the power cord from the power outlet.
11. Turn off the unit after it runs at least five minutes, otherwise it will influence the oil return of the compressor.
12. Do not allow children to operate this unit.
13. Do not operate this unit with wet hands.
14. Turn off the unit or disconnect the power supply before cleaning the unit. This will avoid possible electric shock or personnel injury.
15. Never spray or splash water towards the unit. This can cause a malfunction in the unit or can result in electric shock.
16. Do not expose the unit to moist or corrosive environments.
17. While operating in cooling mode, do not set the indoor units room temperature too low. Keeping the temperature difference between indoor and outdoor unit within 41°F (5°C).
18. YMGI Group recommends that only properly trained and authorized personnel be allowed to repair or service the unit. Improper repairs or servicing can result in electric shock or fire hazards. Please contact YMGI Group if you need help locating a qualified repair or service technician.
19. Before installation, check the power supply to ensure it is sufficient to meet and is in accordance with the requirements specified on the nameplate of the unit. Ensure the power overload is functioning correctly and make sure it is properly maintained.
20. Installation must be performed only by an authorized installer or HVAC professional in accordance with the requirements set by the NEC and CEC. Do not attempt to install the unit yourself. Improper handling may result in water leakage, electric shock, fire, and voiding of the warranty.
21. Be sure to use only approved accessories and parts to prevent water leakage, electric shock and fire.
22. Make sure the unit is grounded properly prior to connecting to power source, to avoid electric shock. Do not connect the ground wire to a gas pipe, water pipe, lightning rod or telephone line.
23. Energize the unit for 8 hours before operation. Turn off or disconnect the power within 24 hours to prevent short-cycling (to protect the compressor).
24. If refrigerant leakage happens in a confined space during installation, ventilate immediately. Poisonous gases can occur if the refrigerant gas is exposed to fire.
25. Volatile liquids, (such as paint thinners or solvents) if exposed to the unit's surface will damage to the surface finish. Only use a soft cloth along with a mild non-abrasive detergent to clean the outer casing of the unit.
26. If the unit does not operate normally or if you notice any type of burning odor, power off the unit and turn off the main power supply, then immediately contact your YMGI authorized repair service center or HVAC professional.

## **NOTICE**

***YMGI Group will not be responsible for any personal injury or any property damage caused by improper or incorrect installation, improper service or maintenance or by not following the instructions listed in this manual.***

## **SECTION 2**









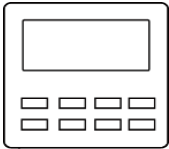
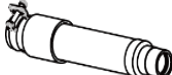

### **Preparing for Installation**

#### **NOTICE**

Product graphics are for reference only. Refer to actual products. Specified units of measure are mm/in.

#### **Standard Fittings**

Use the supplied standard fittings listed below, as instructed.

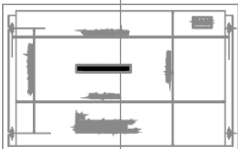
No.	Name	Appearance	Q'ty	Usage
1	Wired Wall Controller		1	To control the indoor unit
2	Drain Hose Assembly		1	To connect with the hard PVC drain pipe
3	Special Nut		1	To be used for connecting the refrigerant pipe
4	M10X8 Nut with Washer		4	To be used together with the hanger bolt for installing the unit.
5	M10 Nut (M10X8.4 Nut)		4	To be used together with the hanger bolt for installing the unit.
6	M10 Washer (Spring Lock Washer M10X2.6)		4	To be used together with the hanger bolt for installing the unit.
7	Insulation		1	To insulate the gas pipe
8	Insulation		1	To insulate the liquid pipe
9	Zip Tie		8	To fasten the sponge
10	Hanger	 or 	4	To mount the indoor unit
11	Nut with Washer		8	To fix the hook on the cabinet of the unit.
12	Mounting Template for installation		1	Locate the drill hole on ceiling

## Accessories

Any accessories determined by the installation technician.

## Location Considerations

**When selecting a location for the indoor unit installation, consider the following:**

1. The unit must not be installed in areas that are wet, damp or in areas where the unit could encounter water. (i.e. such as in a laundry room).
2. The method of attachment and the ceiling structure being attached to must be strong enough to support the unit's weight. Test the attachments before installing the unit.
3. The ceiling must not be subjected to constant vibration.
4. Care should be taken to prevent harmonics generated by loose or unsupported material in close proximity to a running unit.
5. Create a schematic for routing the refrigerant tubing and the electrical wire to the outdoor unit prior to installation.
6. The air in the area that is to be heated/cooled must be able to circulate freely through the intake and discharge.
7. Condensate must be routed correctly and safely away from the unit.
8. The unit should be installed in a manner that helps to prevent unauthorized access.
9. There should be adequate space around the unit for proper maintenance and service. Install the indoor unit according to the dimension described below in (Fig1).
10. The unit should be installed in a manner that allows the filter to be changed and cleaned easily.
11. Do not expose the unit to direct sun light or other heat sources, flammable gas or smoke.
12. The unit must not be installed in an area that is exposed to salt, oil, sulfide gas or corrosive environments.
13. The indoor unit and the outdoor unit power cord should be a minimum of 1m (39-3/8 in.) from any TV or radio. Otherwise, these electrical appliances may interfere with the quality of the image and can cause static noise in a radio.
14. The unit should be installed as far away as possible from fluorescent lights so the remote control can maintain a maximum strength signal.

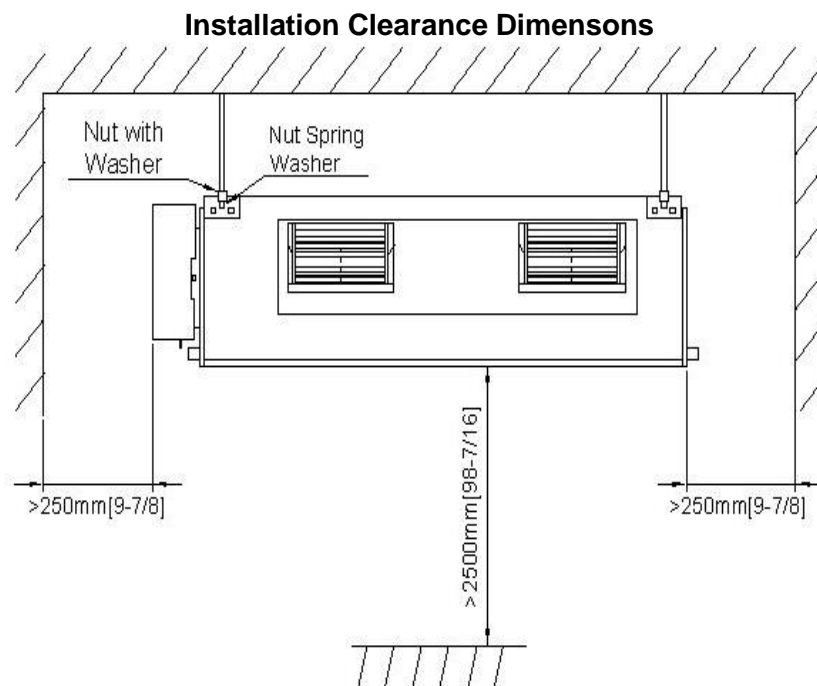

Fig1

## Unit Dimensions

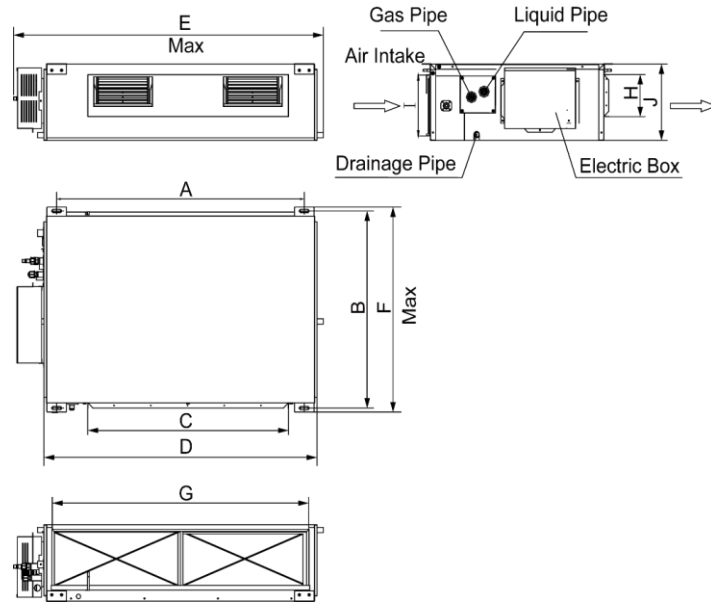

Fig2

Model	A	B	C	D	E	F	G	H	I	J
VRFI-18EF-M2B(55)5	1101	517	820	1159	1271	558	1002	160	235	268
VRFI-24EF-M2B(55)5	(43-3/8)	(20-3/8)	(32-1/4)	(45-5/8)	(50)	(22)	(39-1/2)	(6-1/4)	(9-1/4)	(10-1/2)
VRFI-30EF-M2B(55)5	1101	748	820	1115	1229	775	979	160	231	290
VRFI-36EF-M2B(55)5										
VRFI-42EF-M2B(55)5										
VRFI-48EF-M2B(55)5										

## Service Clearances

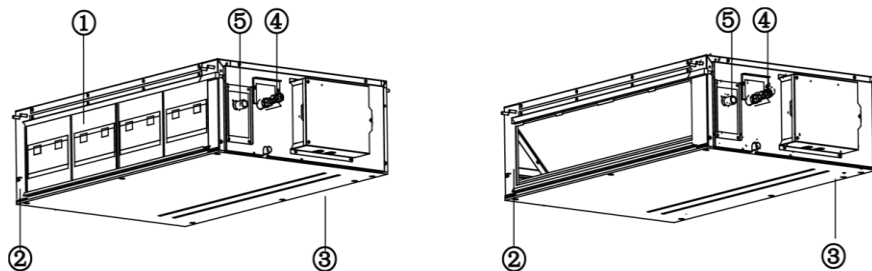

Fig3

Name of Key Components					
No.	①	②	③	④	⑤
Name	Filter Rack	Air Inlet	Air Outlet	Fittings	Drain Pipe



## Rated Working Condition

Indoor Side Condition		
	Dry Bulb Temp °C (°F)	Wet Bulb Temp °C (°F)
Rated Cooling	26.7 (80.0)	19.4 (67.0)
Rated Heating	21.1 (70.0)	15.6 (60.0)

## High Humidity Applications

For high humidity applications, insulate the unit prior to installation.

Outdoor Side Condition		
	Dry Bulb Temp °C (°F)	Wet Bulb Temp °C (°F)
Rated Cooling	35 (95.0)	23.9 (75.0)
Rated Heating	8.3 (47.0)	6.1 (43.0)

## **SECTION 3**

### **Installation Instructions**

#### **Horizontal Mounting the Indoor Unit**

Install the unit with an inspection service access/door after lifting the unit. For easy maintenance, the access/door should be located on the side of the electric box and below the unit's lower level.

#### **NOTICE**

If the unit is to be installed in a ceiling that does not have removable tiles, make allowances for servicing the unit by creating an access hole large enough to easily service the unit.

#### **NOTICE**

- Installation of the unit must be in accordance with the National Electric Codes and all local regulations.
- Improper installation will affect the unit's performance. Do Not Install the unit yourself. Installation should only be performed by an authorized HVAC professional. Contact your local dealer to arrange for your professional installation.
- Do not connect power to the unit until all the installation of the unit is completely finished.

#### **Mounting the unit**

1. Drill bolt holes and install bolts, if the units require mounting to a concrete floor or structure.
  - a. Stick the cardboard template onto the installation position(Fig4).
  - b. Drill 4 holes using the hole pattern on the cardboard template as shown in Fig4.
  - c. The diameter of hole to be drilled is determined by the diameter of expansion bolt and the depth is 60-70mm (2-3/8~2-3/4 in.), as shown in Fig4.

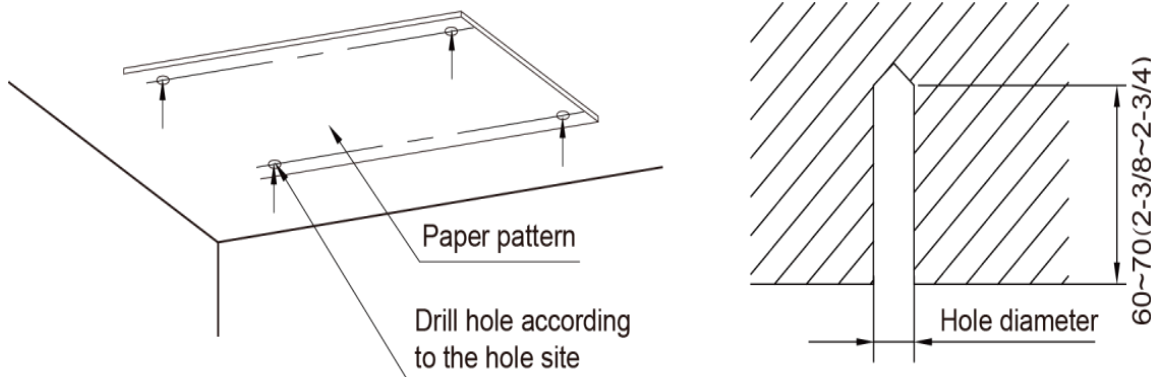

Fig4

- d. Insert the M10 expansion bolt into the hole and hammer the nail into the bolt, as shown in Fig5.
2. When mounting the unit to wood or steel structures use threaded rods, nuts, flat washers and lock washers.

#### **NOTICE**

The length of bolt depends on the installation height of the unit, bolts are field supplied.

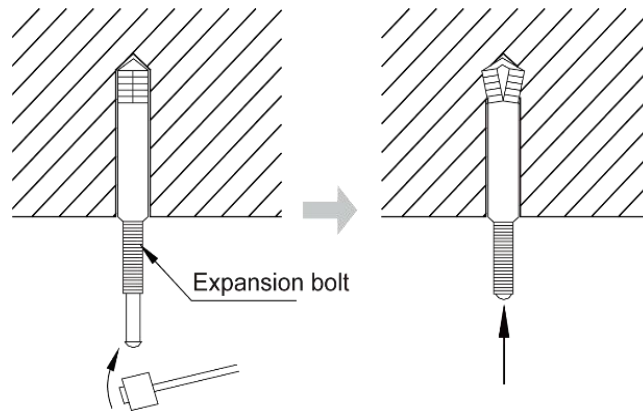

Fig5

2. Install the indoor unit temporarily
  - a. Assemble suspension bolt on the expansion bolt.
  - b. Attach the hanger bracket to the suspension bolt.
  - c. Be sure to fix it securely by using a nut and washer from upper and lower sides of the hanger bracket.
  - d. The washer fixing plate will prevent the washer from falling.
3. The usage of the paper pattern
  - a. Refer to the paper pattern for the installation for ceiling opening dimensions.
  - b. The center of the ceiling opening is indicated on the paper pattern.
  - c. Fix the paper pattern to the unit with 4 screws and fix the corners of the waterspout at the drainage pipe with screws.
4. Adjust the unit to the correct position.
5. Check the unit for level.
  - a. The indoor unit is equipped with a built-in water pump and float switch, verify the unit is level in all 4 directions using a level gauge as shown in Fig6.

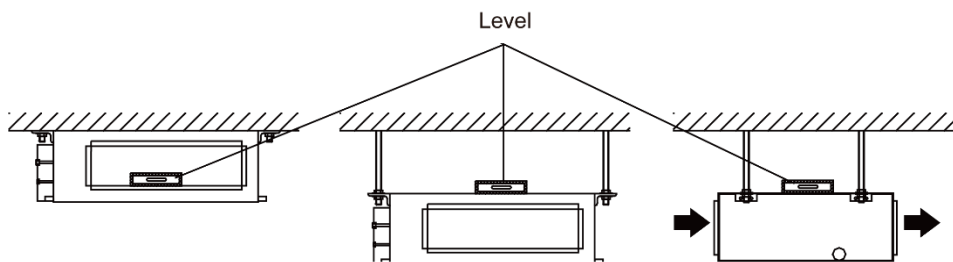

Fig6

6. Remove the paper pattern and mount the unit as shown in Fig7.

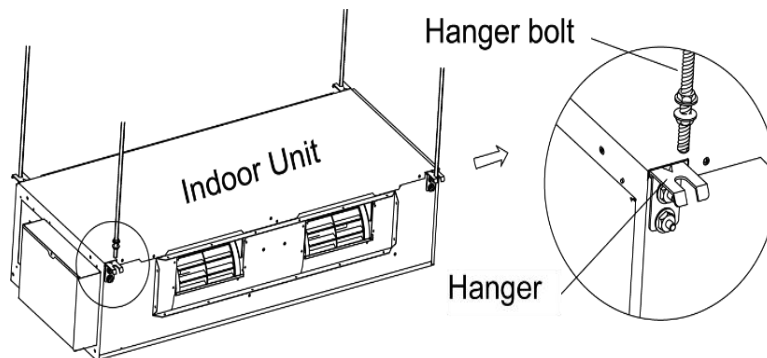

Fig7

## Refrigerant Pipe Connection

### **⚠ WARNING**

#### **Confined Space Hazards!**

Do not work in confined spaces where refrigerant or other hazardous, toxic or flammable gas may be leaking. Refrigerant or other gases could displace available oxygen to breathe, causing possible asphyxiation or other serious health risks. Some gases may be flammable and or explosive. If a leak in such spaces is detected, evacuate the area immediately and contact the proper rescue or response authority. Failure to take appropriate precautions or to react properly to such potential hazards could result in death or serious injury.

### **⚠ WARNING**

#### **Explosion Hazard!**

Never use an open flame to detect gas leaks. It could result in an explosion. Use a leak test solution for leak testing. Failure to follow recommended safe leak test procedures could result in death or serious injury or equipment or property-only-damage.

Use only dry nitrogen with a pressure regulator for pressurizing unit. Do not use acetylene, oxygen or compressed air or mixtures containing them for pressure testing. Do not use mixtures of a hydrogen containing refrigerant and air above atmospheric pressure for pressure testing as they may become flammable and could result in an explosion. Refrigerant, when used as a trace gas should only be mixed with dry nitrogen for pressurizing units. Failure to follow these recommendations could result in death or serious injury or equipment or property-only damage.

Do not exceed unit nameplate design pressures when leak testing system. Failure to follow these instructions could result in an explosion causing death or serious injury.

### **NOTICE**

- All required piping pressure tests must be completed in accordance with national, state and/or local codes.
- When leak-testing refrigerant systems, observe all safety precautions.
- Leak test to 590 psig to minimize system exposure to potentially harmful moisture in the air.
- Use R-410A refrigerant gas as a tracer for leak detection and use oil-pumped dry nitrogen to develop required test pressures.
  - a. Close liquid line angle valve.
  - b. Connect R-410A refrigerant cylinder to high side charging port (at condenser or field supplied discharge line access port). Add refrigerant to reach pressure of 12 to 15 psig.
  - c. Disconnect refrigerant cylinder. Connect dry nitrogen cylinder to high side charging port and increase pressure to 150 psig. Do not exceed high side (discharge) unit nameplate design pressure. Do not subject low side (suction) components to high side pressure.
  - d. Check all piping joints, valves, etc. for leaks. Recommend using electronic detector capable of measuring 0.1 oz/year leak rate.
  - e. If a leak is located, use proper procedures to remove the refrigerant/nitrogen mixture, break connections and make repairs. Retest for leaks.
  - f. Make sure all service valves are open.

## Pipe Flaring

1. Place the tapered end of the threaded fitting into the flared copper pipe. Push the flaring nut onto the threaded fitting and secure it by turning the flaring nut until it is finger tight. Using 2 wrenches to tighten the fitting to the recommended torque, listed in the table below. (Fig8).
2. Tighten the flaring nut with torque wrench.

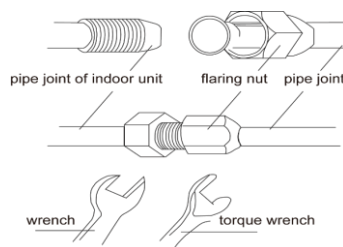

Torque for tightening nut	
Pipe diameter mm(inch)	Torque (N·m)
9.52(3/8)	35~40
15.9(5/8)	60~65

Fig8

3. Use a pipe bender when it is necessary to bend the pipe. The bending angle should not be too small as not to crush the pipe.
4. Wrap the pipe connection and joint with foam insulation and then secure them firmly with tape.

## Installation of Drainage for Indoor Unit

### 1) Drainage Installation

1. The drainage pipe should be short and the gradient downwards should be at least 1% ~ 2% to drain condensation water properly.
2. The diameter of the drainage hose should be bigger or equal to the diameter of the drainage pipe joint.
3. Install the drainage pipe according to the following (Fig9) and attach the insulation to the drainage pipe. **NOTE:** Improper installation may lead to water leakage.
4. You can use normal hard PVC pipe for the drainage pipe. During connection, insert the end of the PVC pipe into the drainage hole and then tighten. Do not connect the drainage pipe to the drainage hole with glue.
5. When a single drainage pipeline is used for several units, the position of the pipelines should be about 100mm (4 in.) lower than the drainage port of each unit. In this case, pipes with a large wall thickness should be used.

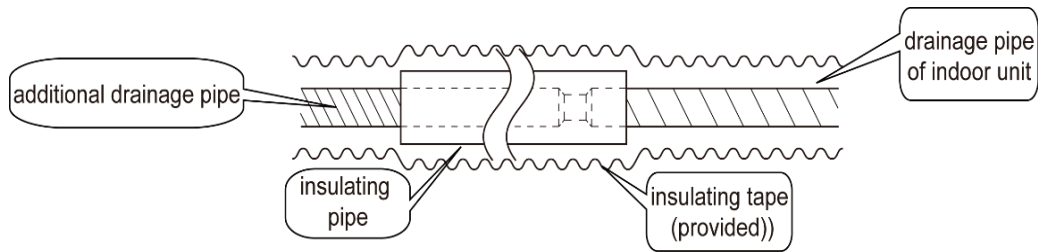

Fig9

### 2) Drainage Pipe Installation

1. Insert the drain hose into the drain hole and secure with clamp, as shown in (Fig10).
2. Tighten the pipe clamp, with the distance  $\leq 4$  mm (3/16 in.) between screw nut and hose.
  - a. metal clamp (① accessory)
  - b. drain hose (② accessory)
3. Use the foam insulation provided to insulate the clamp and hose, as shown in (Fig11).
  - a. metal clamp (① accessory)
  - b. thermal sponge (② accessory)

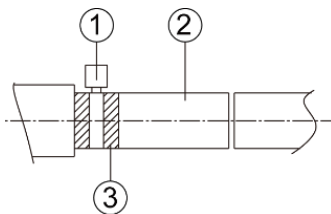

Fig10

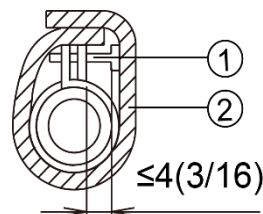
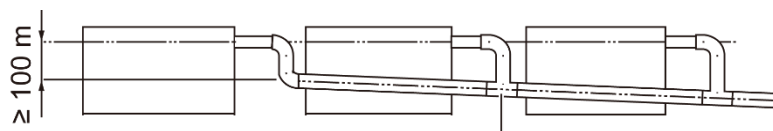

Fig11

- d) When connecting several drain pipes, follow the instruction as indicated in (Fig12).
- e) Choose the drain collecting pipe that matches with unit capacity.



T Joint of Collecting Pipe

Fig12

- f) Install the trap as shown in (fig13).
- g) Install one trap for each unit.
- h) Maintenance and service for the trap should be considered when installing it.

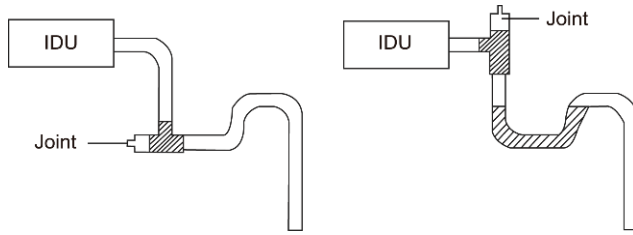

Fig13

i) The horizontal pipe can be connected to a vertical pipe in the same level. Select one of the connection methods as shown in following figure below.

- i Connection of drainage pipe joints (Fig14)
- ii Connection of downspout elbow (Fig15)
- iii Inserting pipe connection (Fig16)

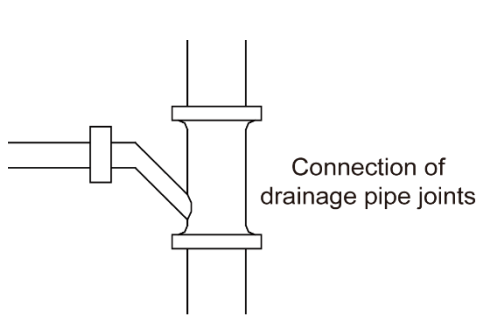

Fig14

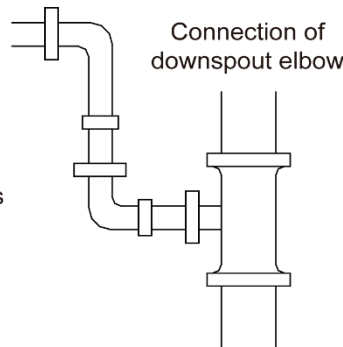

Fig15

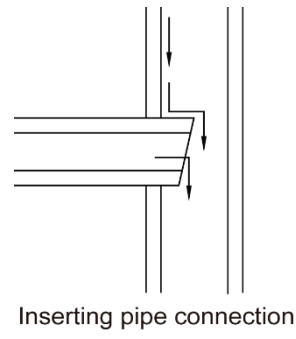

Fig16

j) The installation height for the raising pipe for drainage should be lower than B. The gradient from the raising pipe towards the drainage direction should be at least 1%~2%. If the raising pipe is vertical with the unit, the raising height should be less than C (Fig17).

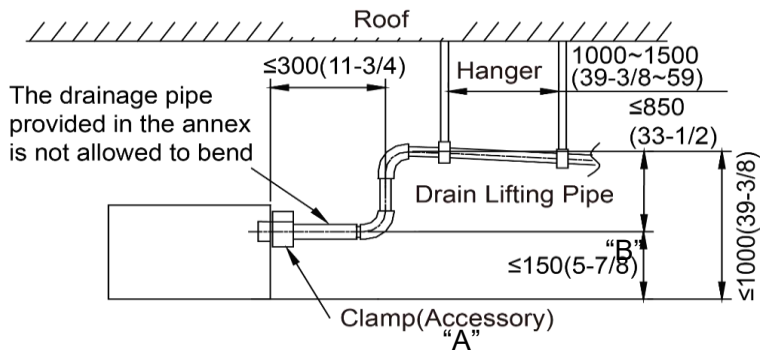

Fig17

"C"

Model	A(mm/in.)	B(mm/in.)	C(mm/in.)
VRFI-18EF-M2B(55)5 VRFI-24EF-M2B(55)5 VRFI-30EF-M2B(55)5 VRFI-36EF-M2B(55)5 VRFI-42EF-M2B(55)5 VRFI-48EF-M2B(55)5	150(5-7/8)	850(33-7/16)	800(31-1/2)

- k) Drain pipes should have a downward slope of at least 1%~2%. To prevent pipes from sagging, install hanger brackets at intervals of 1000 ~ 1500 mm (39-3/8 ~ 59 in.) (Fig18).

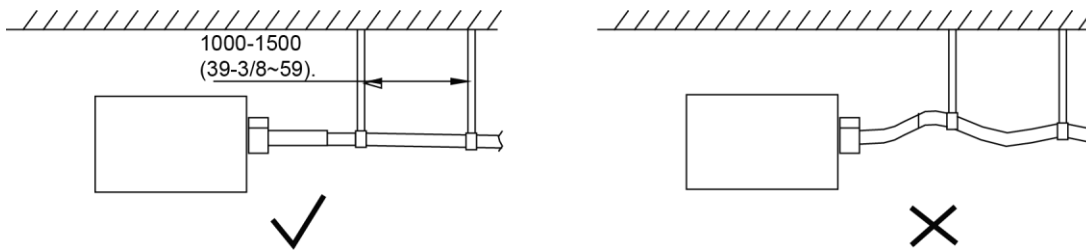

Fig18

### 3) Test of Drainage System

1. Test the drainage system after all electrical work is finished.
  - a. Inject approximately 1L of purified water into the drain pan from the air vent, being careful not to splash water onto the electrical components (e.g. water pump. Etc. Fig19).
2. When commissioning is finished, energize the IDUs and switch them to cooling mode or dry mode. While the water pump is operating, check unit for drainage through the drain socket.
3. If the communication wire is not connected, a communication malfunction "C0" error will occur after 60 seconds of energizing. In this case, the water pump operates automatically. Check the water pump to see if it is draining normally through the drainage port. The water pump will stop automatically after running for 10 minutes.
4. During the test, carefully check the drainage joint, make sure no leakage has occurred.
5. It is strongly recommended to do the drain test before closing or finishing the ceiling.

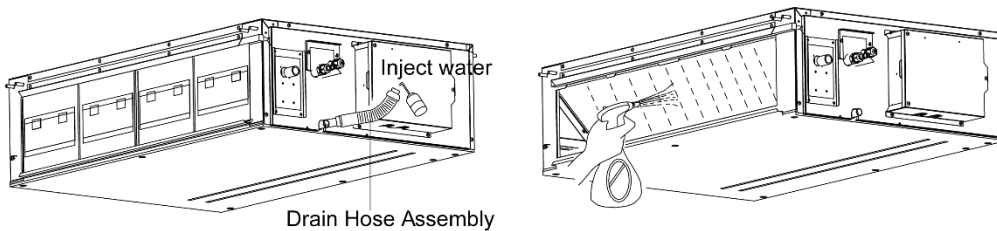

Fig19

## Installation of Air Duct

### **NOTICE**

- There should be an insulating layer on the air-outlet duct, air-return duct and the fresh air duct to avoid heat loss and moisture.
- Each air-outlet duct and air-return duct should be mounted onto a fixed panel or on a metal frame. The junction of the air duct should be sealed to prevent air leakage.
- The design and construction of the air duct should comply with national requirements.
- The edge of air-return duct is should be more than 150 mm (5-7/8 in.) away from a wall. Add a filter to the air-return opening.

- Consider noise-damping and vibration damping for the design and construction of the air duct. Air ducts can be noisy, so if possible locate the ducts in areas where they do not have direct contact with people. For instance, do not have the air-return opening installed on top of the user (Offices, rest area, etc.).
- Installation of Air-out Duct
  1. Installation of the Rectangular Duct (Fig20)
  2. Shape and Size of Air Outlet and Air-return Opening (Fig21)

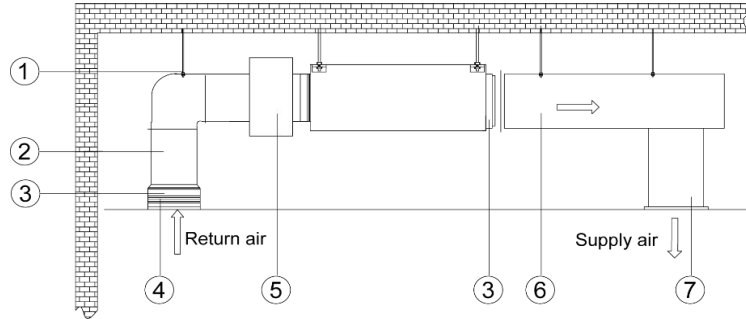

Fig20

No.	Name	No.	Name
1	Hanger Rod	5	Static Pressure Box
2	Return Air Duct	6	Main Supply Air Duct
3	Canvas Duct	7	Supply Air Outlet
4	Return Air Inlet		

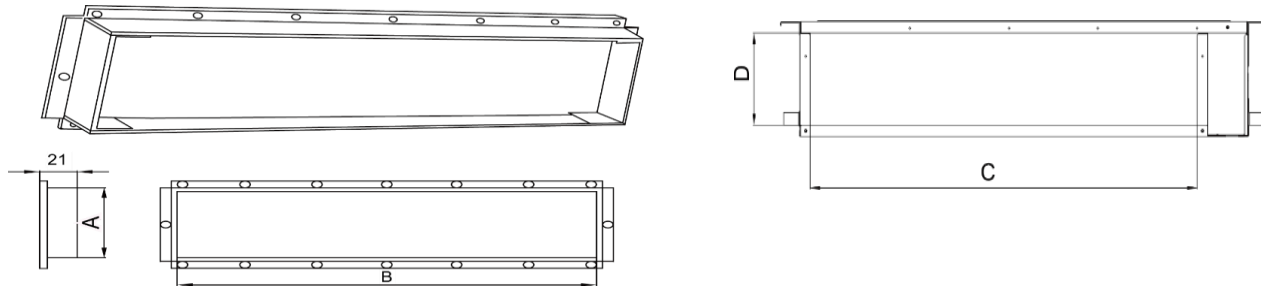

Fig.21 (Air Outlet and Air-return Opening)

Model	Size of Air Outlet		Size of Air – Return Opening	
	A	B	C	D
VRFI-18EF-M2B(55)5 VRFI-24EF-M2B(55)5	158 (6-1/4)	818 (32-1/4)	994 (39-1/8)	195 (7-5/8)
VRFI-30EF-M2B(55)5 VRFI-36EF-M2B(55)5 VRFI-42EF-M2B(55)5 VRFI-48EF-M2B(55)5	158 (6-1/4)	818 (32-1/4)	100 (3-7/8)	206 (8-1/8)



## Installation of the Return Air Duct

- 1) The default installation location of the rectangular flange is at the back and the return air cover plate is at the bottom, as shown in Fig22.

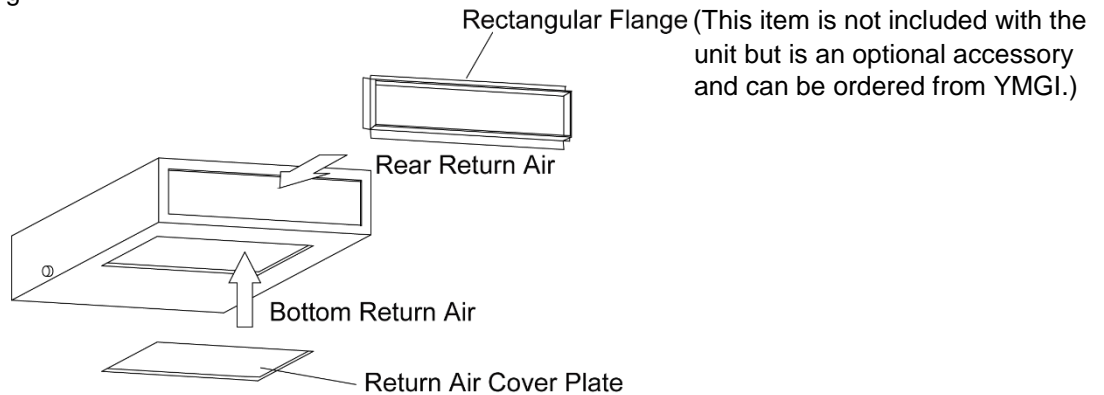

Fig22

- 1) The installation method can be chosen with considering the conditions of the building and maintenance etc., as shown in Fig23.

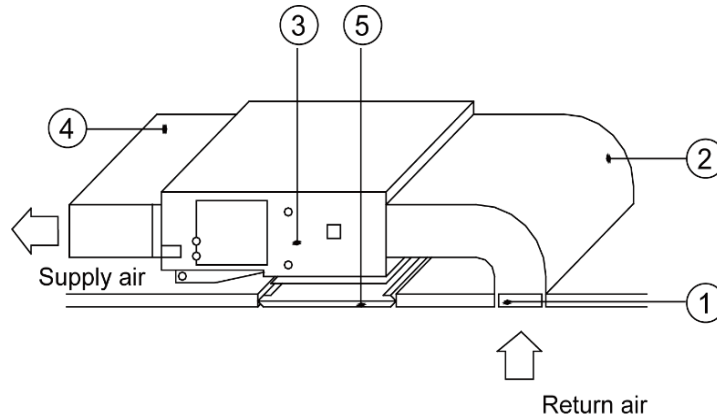

Fig23

Table 5 Installation of the return air duct

No.	Name	No.	Name
1	Return Air Inlet (with filter)	4	Supply Air Duct
2	Return Air Duct	5	Grille
3	Indoor unit		

Rectangular Return Air Duct Connection Flange

No.	Part Number	Models	Remarks
1	YMGI-		
2	YMGI-		

## SECTION 4

### Wiring the units

#### Requirements for Communication Line (Fig24 and Fig25)

#### NOTICE

➤ If the unit is installed where there is a strong electro-magnetic field which can interfere with the unit operation, A STP (shielded twisted pair) communication cable must be used.

1. Select the Communication Line for the Indoor Unit and the Wall Controller

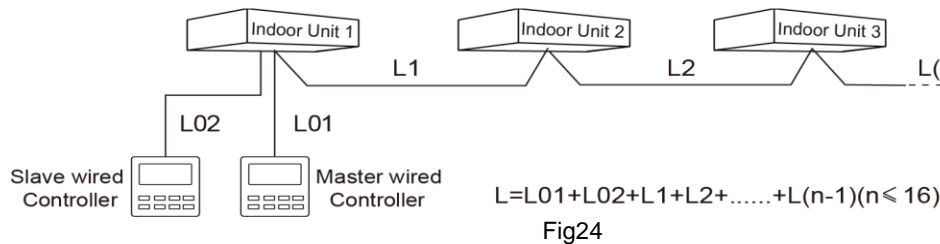

Material type	Total length of communication line between indoor unit and wired controller L (m/ft.)	Wire size (mm <sup>2</sup> /AWG)	Material Standard	Remarks
Light/Ordinary polyvinyl chloride sheathed cord. (60227 IEC 52 /60227 IEC 53)	$L \leq 250m$ ( $L \leq 820-1/5ft.$ )	$2 \times 0.75 \sim 2 \times 1.25$ ( $2 \times AWG18 \sim 2 \times AWG16$ )	IEC 60227-5	<ol style="list-style-type: none"> <li>1. Total length of communication line can't exceed 250m (820-1/5ft.).</li> <li>2. The cord shall be Circular cord (the cores shall be twisted together).</li> <li>3. If unit is installed in places with intense magnetic field or strong interference, it is necessary to use shielded wire.</li> </ol>

2. Select Communication Line for Indoor Unit and Outdoor Unit

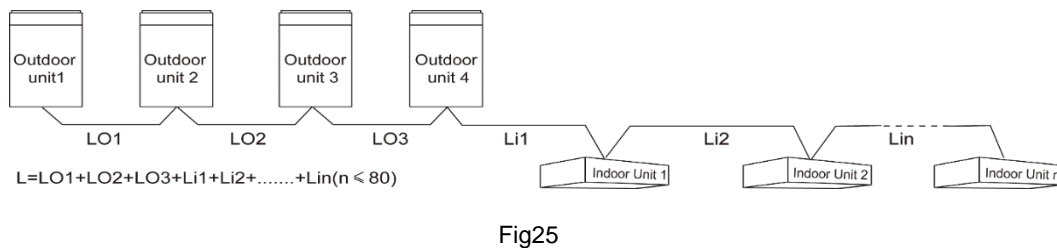

Material Type	Total Length L (m/ft.) of Communication Cable between Indoor Unit and Indoor (Outdoor) Unit	Wire size (mm <sup>2</sup> /AWG)	Material Standard	Remarks
Light/Ordinary polyvinyl chloride sheathed cord. (60227 IEC 52 /60227 IEC 53)	$L \leq 1000m$ ( $L \leq 3280-5/6ft.$ )	$\geq 2 \times 0.75$ ( $\geq 2 \times AWG18$ )	IEC 60227-5	<ol style="list-style-type: none"> <li>1. If the wire diameter is enlarged to <math>2 \times 1 \text{ mm}^2</math> (<math>2 \times AWG16</math>), the total communication line length can reach 1500 m (4921-1/4ft.).</li> <li>2. The cord shall be Circular cord (the cores shall be twisted together).</li> <li>3. If unit is installed in places with intense magnetic field or strong interference, it is necessary to use shielded wire.</li> </ol>

## Wiring Power Requirements

### 1) Power Cord Size and Air Switch Capacity

Model	Power Supply	MCA(A)	MOP(AMP) (Circuit Breaker Size)
VRFI-18EF-M2B(55)5	208~230V-1PH-60Hz	0.9	15
VRFI-24EF-M2B(55)5		0.9	15
VRFI-30EF-M2B(55)5		1.4	15
VRFI-36EF-M2B(55)5		1.4	15
VRFI-42EF-M2B(55)5		1.6	15
VRFI-48EF-M2B(55)5		1.6	15
VRFI-72EF-H2B(55)5		5.0	15
VRFI-96EF-H2B(55)5		6.0	15

Each indoor unit can be individually supplied with a dedicated circuit breaker or fuse.

#### **NOTICE**

- Use copper wire only for the unit's power cord. Operating temperature should be within its rated value.
- If the power cord is more than 15 m (49 - 1/4 ft.) long, then the power cord must be properly resized to carry the rated loads over the greater distance. This will must be done to allow the unit to function properly. Otherwise this could result in unit failure and power cord overload.
- Above selection requirements: Power cord size is based on BV single-core wire (2~4pc) at 40° (104°F) Ambient temperature when laying across plastic pipe. Air switch is D type and used at 40°C (104°F). If the actual installation conditions vary, lower the capacity appropriately according to the specifications of the power cord and air switch provided by manufacturer.
- Install the cut-off device near the unit. The minimum distance between each stage of the cut-off device should be 3 mm (1/8 in.) (The same for both the indoor unit and the outdoor unit).

### 1) Installation of Wall Mounted Controller

- a) Refer to the User Manual for the Wall Mounted Controller for installation details.

#### **NOTICE**

**When installation is finished, the unit must be tested before operation. Refer to Instruction Manual of the ODU for auto addressing and troubleshooting details.**

### 2) Wiring the Unit

#### **⚠ WARNING**

Before obtaining access to wiring terminals, all power supply circuits must be disconnected.

#### **⚠ WARNING**

#### **Hazardous Voltage!**

Disconnect all electric power, including remote disconnects before servicing. Follow proper lockout/tagout procedures to ensure the power cannot be inadvertently energized. Failure to disconnect power before servicing could result in death or serious injury.

#### **NOTICE**

#### **Use Copper Conductors Only!**

Unit terminals are not designed to accept other types of conductors. Failure to use copper conductors could result in equipment damage.

## NOTICE

- Units must be securely grounded. Failure to do so may result in an electric shock.
- Please carefully read the wiring diagram before wiring. Incorrect wiring could cause the unit to malfunction and could also damage the unit.
- The unit should be connected by an independent circuit and a specific socket.
- The wiring should be performed in accordance with all NEC codes and all local codes and regulations to ensure the unit operates as intended.
- Install a circuit breaker for the branch circuit according to all NEC codes and all local codes and regulations.
- Keep power cable away from refrigerant pipes, compressor and fan motor.
- The communication wires should be separated from the power cord and connection wire between the indoor unit.
- Adjust the static pressure via the wired controller according to site requirements.
- Make all electrical connections in accordance with electrical codes and ordinances.
- Select the power cable in accordance with relevant local and national regulations.
- Wire size must comply with local and national code.
- Use grade H07RN-F or H05RN-F power cable.
- Connect the power cable into the power cable terminal and fasten it with a clamp.
- Unbalanced power must be maintained within 10% of supply rating among whole indoor units.
- Significantly unbalanced power may shorten the life of the system. If the unbalanced power is greater than 10% of supply rating, the unit will stop and an error code will be generated.
- Connect the power cable to the auxiliary circuit breaker. An all-pole disconnection from the power supply must be incorporated in the field wiring (1/8 in. [3 mm]).
- All wiring must be protected from weather and damage.
- Maintain a space of 2 inches (50 mm) or more between the power and communications cables to prevent interference.
- Maintain a voltage drop of less than 10% between the power source and the unit(s).
- Use an appropriate screwdriver for tightening the terminal screws. A screwdriver with a small head will strip the head and make proper tightening impossible.
- Over-tightening the terminal screws may break them.
- After making a knockout hole, apply rust-preventive paint to the bare metal around the hole.
- Secure the cable conduit to the outdoor knockout using the proper connector and bushing.

### 4) Connection of Wire and Patch Board Terminal

1. Connect wire (as shown in Fig26)
2. Strip about 25mm (1 in.) insulation off the end of wire.
3. Remove the appropriate screws from the terminal board.
4. Shape the stripped portion of the wire into a hook making the ID large enough to fit the screw.
5. Secure wire to the terminal board.

### 5) Connecting stranded wire (as shown in Fig27)

1. Strip about 10mm (3/8 in.) insulation off the end of wire.
2. Insert the stripped end of the wire into the barrel end on the terminal and crimp terminal to secure wire.
3. Remove the appropriate screws from the terminal board.
4. Attach wire to the terminal board by inserting the screws through the terminals and tighten.

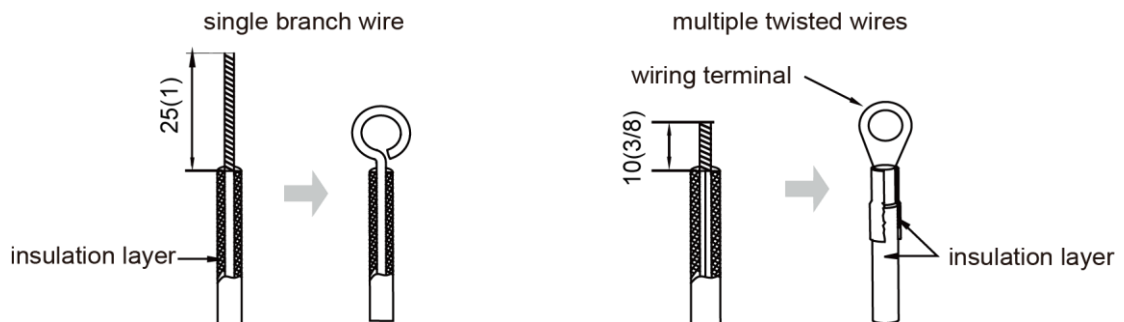

Fig26

Fig27

## 6) Power Cord Connection

### **NOTICE**

- Every unit should be equipped with a circuit breaker for short-circuit and overload protection.
- In general, circuit breaker is in OFF. During operation, all indoor units and outdoor units connected to the same system must also be kept energized. Otherwise, the unit can't operate normally.
  1. For units with single-phase power supply.
  2. Remove the cover from the electrical box.
  3. Route the power cord through the wiring access holes.
  4. Connect the wires of the power cord to terminals "L1, L2,  $\oplus$ ".
  5. Secure the power cord with wiring clamp.
  6. The wire diameter of the power cord must be 18AWG minimum.

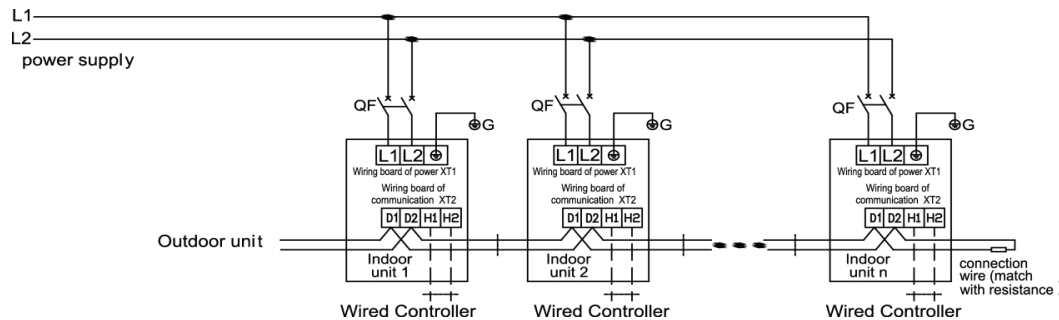

Fig28

## 7) Communication Wire between the Indoor Unit and the Outdoor Unit (or indoor unit)

1. Remove the cover to the electrical box.
2. Route the Communication cable through the wiring access holes.
3. Connect the communication wire to terminal D1 and D2 of indoor 4-bit wiring board, as shown in Fig29.

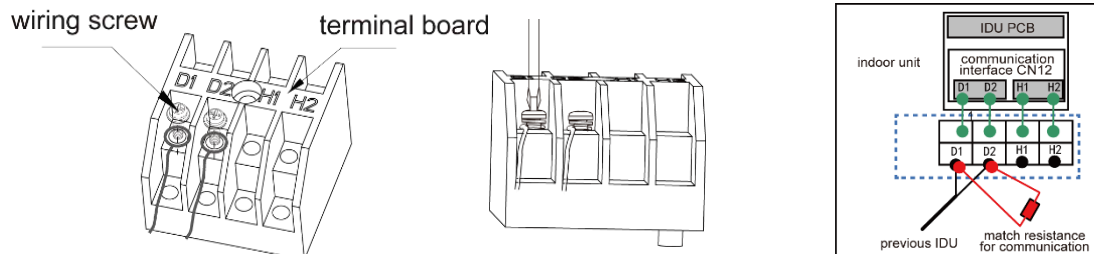

Fig29

## 8) Attach the communication cable with clamp inside the electrical box.

1. For more reliable communication, make sure to connect the terminal resistor to the most downstream IDU of the communication bus (terminal D1 and D2), as shown in Fig29 the terminal resistor is provided with each ODU.

## 9) Connecting the communication Wire of the Wired Controller

1. Open the electrical box cover of the indoor unit.
2. Route the communication wire through the rubber grommet.
3. Connect the communication wire to terminal H1 and H2 of the indoor 4-bit wiring board.
4. Attach the communication wire with a wire clip on the electrical box.
5. Wiring instructions of remote receiving light board and wired controller:
6. Fig30 shows the installation of the wired controller.

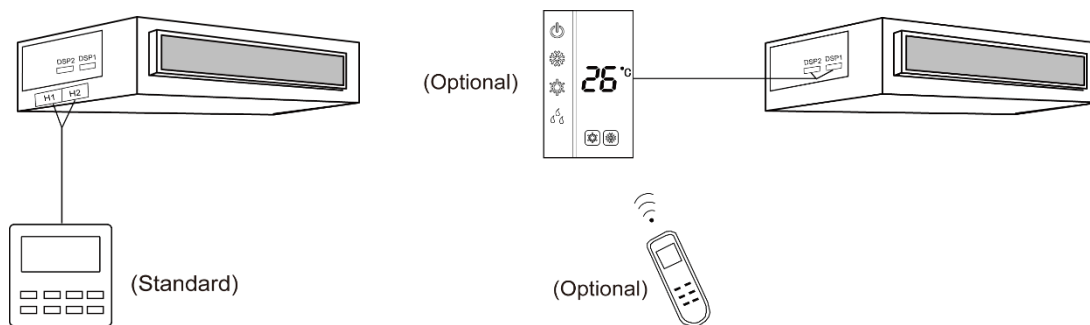

Fig30

- 7) Fig31 shows the installation of the remote controller.
- 8) The wired controller and the receiving light board can be installed at the same time. When operating through a remote controller, both the wired controller and the receiving light board can receive the signals, as shown in Fig31.

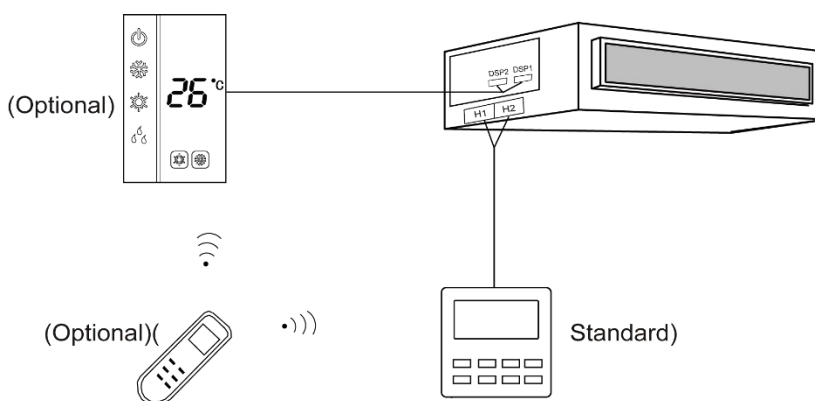

Fig31

#### 10) Illuminated Connection of Wired Controller and Indoor Units Network

1. The communication wire of the indoor unit and the outdoor unit (or indoor unit) is connected to D1, D2.
2. The wired controller is connected to H1, H2.
3. One indoor unit can be connected to two wired controllers. One controller must be set as the master and the other as a slave.
4. One wired controller can control a maximum of 16 indoor units at the same time. (Fig32).

#### **NOTICE**

- All indoor units must be the same if they are controlled by the one wired controller.
- When the indoor unit is controlled by two wired controllers, the indoor unit addresses of the two wired controllers should be different and can be set through the address settings. Address 1 is for the main controller; Address 2 is for the slave controller. For detailed setting refer to the instruction manual for the wired controller.

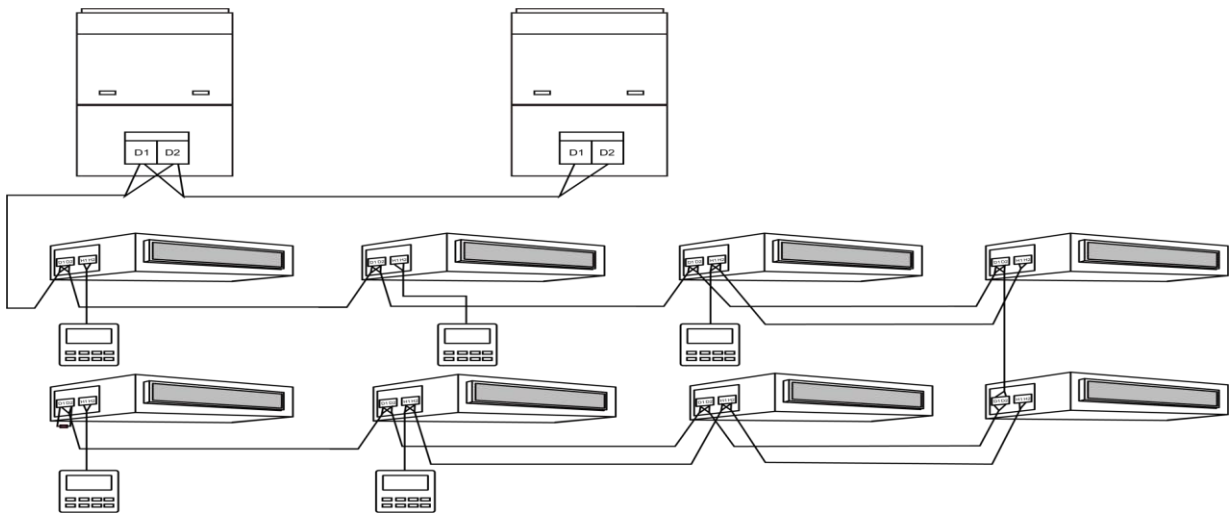

Fig32

## **SECTION 5**

### **Routine Maintenance**

#### **NOTICE**

- Turn off the unit and the main power supply before cleaning the air conditioner to avoid electric shock or injury.
- Do not clean the unit with water that has a temperature higher than 45°C/113°F to prevent fading or part deformation.
- Clean the filter with a wet cloth and mild nonabrasive detergent.
- After cleaning the filter allow it to air dry completely before placing back into the unit.

#### **1) Cleaning the Filters**

1. Remove the filters from the IDU inlet. Use a vacuum cleaner to remove any dust. If the filters are dirty, wash them with warm water and a mild detergent. Air dry the filters completely in an area where they will not be exposed to direct sunlight.
2. If the unit operates in a dusty environment, clean the unit and its filters regularly. (Usually once every two weeks).

#### **2) Maintenance before Seasonal Use**

1. Make sure that there is nothing obstructing the air inlet and the air outlet on both the indoor and outdoor units.
2. Check the unit to make sure it is securely grounded.
3. Check the power cord and the communication cable and ensure they are securely connected.
4. Check if there are any error codes displayed after the indoor and outdoor units have been energized.

#### **3) Maintenance after Seasonal Use**

1. Set the unit in fan mode and run for half a day to dry the inner part of unit.
2. If the unit will not be in use for an extended period of time, turn the unit off. By turning off the power supply to the unit, this will save on energy usage.
3. The characters on the wired controller screen will disappear after turning the unit off.



## **SECTION 6**

**Table of Error Codes for the Indoor Unit**

Error Code	Content	Error Code	Content	Error Code	Content
L0	Indoor Unit Error	LA	Indoor Unit Incompatibility Error	d9	Jumper Cap Error
L1	Indoor Fan Protection	LH	Low Air Quality Warning	dA	Indoor Unit Network Address Error
L2	E-heater Protection	LC	ODU-IDU Incompatibility Error	dH	Wired Controller PCB Error
L3	Water Full Protection	d1	Indoor Unit PCB Error	dC	Capacity DIP Switch Setting Error.
L4	Wired Controller Power Supply Error	d3	Ambient Temperature Sensor Error	dL	Outlet Air Temperature Sensor Error
L5	Freeze protection	d4	Inlet Pipe Temperature Sensor Error	dE	Indoor Unit CO2 Sensor Error
L7	No Master Indoor Unit Error	d6	Outlet Pipe Temperature Sensor Error	dy	Water Temperature Sensor Error
L8	Power Insufficiency Protection	d7	Humidity Sensor Error	C0	Communication Error
L9	Quantity of Group Control Indoor Units Setting Error	d8	Water Temperature Error	AJ	Filter Cleaning Reminder
db	Special Code: Field Debugging Code				

## **SECTION 7**

### **Troubleshooting**

The air conditioner is not expected to be serviced by its end users. Repairs that are not correctly made can damage the unit which may cause electrical shock or fire. Contact an authorized service center to schedule a professional HVAC technician to repair or service the air conditioner.

Prior to contacting your service center, check the following table as it may save you some time and money.

Problem	Troubleshooting
The unit will not start	<ul style="list-style-type: none"><li>① Make sure the power supply is connected.</li><li>② Make sure the circuit breaker is not tripped.</li><li>③ Input voltage is too low.</li><li>④ There is a problem within the main PC-board.</li></ul>
The unit stops after running for a while.	<ul style="list-style-type: none"><li>① The inlet or outlet of the ODU or the IDU may be blocked.</li></ul>
Poor cooling effect	<ul style="list-style-type: none"><li>① The filter is dirty.</li><li>② The heat load on the room is too great (e.g. too many people)</li><li>③ A door or window may be open.</li><li>④ The inlet and outlet of the IDU may be blocked.</li><li>⑤ The set temperature is too high.</li><li>⑥ Refrigerant is low.</li></ul>
Poor heating effect	<ul style="list-style-type: none"><li>① The filter is dirty.</li><li>② A door or window may be open.</li><li>③ The set temperature is too low.</li><li>④ Refrigerant is low.</li></ul>
Indoor fan doesn't start during heating	<ul style="list-style-type: none"><li>① When starting, the IDU fan will not operate until the heat exchanger is heated. This prevents cool air from being blown into the room.</li><li>② While defrosting, the IDU fan is stopped because the system switches to cooling mode. This prevents cool air from being blown into the room. Normal operation will resume after defrosting.</li></ul>

### **NOTICE**

If the air conditioner still fails to work normally after checking and troubleshooting as described above, turn the unit off immediately and contact your local service center for assistance.

**SECTION 8**

**WIRED WALL CONTROL**

**SECTION 8**

**INSERT REMOTE CONTROL HERE**

## **SECTION 10**

Customer service and Technical Support.



YMGI Group  
O'Fallon, MO 63366  
[www.ymgigroup.com](http://www.ymgigroup.com)  
[www.ymgihvacsupply.com](http://www.ymgihvacsupply.com)

