



## Submittal Data Sheet: WMMS-12EL-V2B(59)2

### INDOOR UNIT



Remote Control



**WMMS-12EL-V2B(59)2**

### ACCESSORIES

- REPLACEMENT FILTERS
- THERMOSTAT
- MOUNTING BRACKETS
- COPPER/WIRE/ACC.SET
- BRIDGE CONTROLLER

Model	WMMS-12EL-V2B(59)2	
<b>Connection Pipes</b>		
Liquid Connecting Pipe Diameter	in.	Ø1/4
Gas Connecting Pipe Diameter	in.	Ø3/8
Drain Pipe External Diameter	in.	Ø 0.67
Drain Pipe Internal Diameter	in.	Ø 0.59
<b>Dimensions &amp; Weight Indoor Unit</b>		
Dimensions (W x D x H)	in.	27 5/9 x 8 1/2 x 23 5/8
Net/Gross Weight	lbs.	35.3/41.9

Job Name:		Tag #:	
Location		Date:	
General Contractor:		Mechanical Contractor:	
Sales Representative:		Sales Engineer:	
Submitted by:		Drawing #:	
Reference		PO #:	

#### Sweet Comfort

With it's thoughtful design, you can keep your head and feet comfortable. High or low wall mounting options, combined with high and low discharge vents allow you to quickly heat or cool whichever portion of the room needs it most, keeping you comfortable all year.

#### Multiple Fan Speed

The fan can operate at multiple speeds and satisfy different air flow volume requirements.

#### Detachable Grille and Long Life Filter

Grille is detachable for easy cleaning. Our long life filter, can go up to 20 times longer between cleaning cycles.

#### Compact Profile

8 1/2 inch compact profile makes installation easy while using minimal wall or floor space.

#### Digital Display

Users and service technicians can use the digital display on the controller to see status and protection or error codes.

#### Thermostat Controller

By using a YMGI bridge controller, North American style thermostats (Nest, Honeywell, Pro1, YMGI etc.) can be used for temperature control, locally or remotely, individually or in groups.

Model	WMMS-12EL-V2B(59)2	
Cooling Capacity	Btu/h	12000
Heating Capacity	Btu/h	13500
Power Supply	V/Ph/Hz	208/230/1/60
Power Consumption	W	20
Airflow Volume	m³/h	480
	CFM	282
Related Current Heating / Cooling	Amp	0.4
MCA	Amp	0.5
MOP	Amp	15
Sound Pressure Level	dB(A)	40
Refrigerant		R410A



# Submission Data Sheet: WMMS-12EL-V2B(59)2

## INDOOR UNIT

Dimensions (inches)	
	inches
W	27 5/8"
H	23 5/8"
D	8 1/2"
A	20"
B	12"
C	7 3/4"
E	7 3/4"
F	4 1/4"
G	21 3/4"
I	2 1/2"

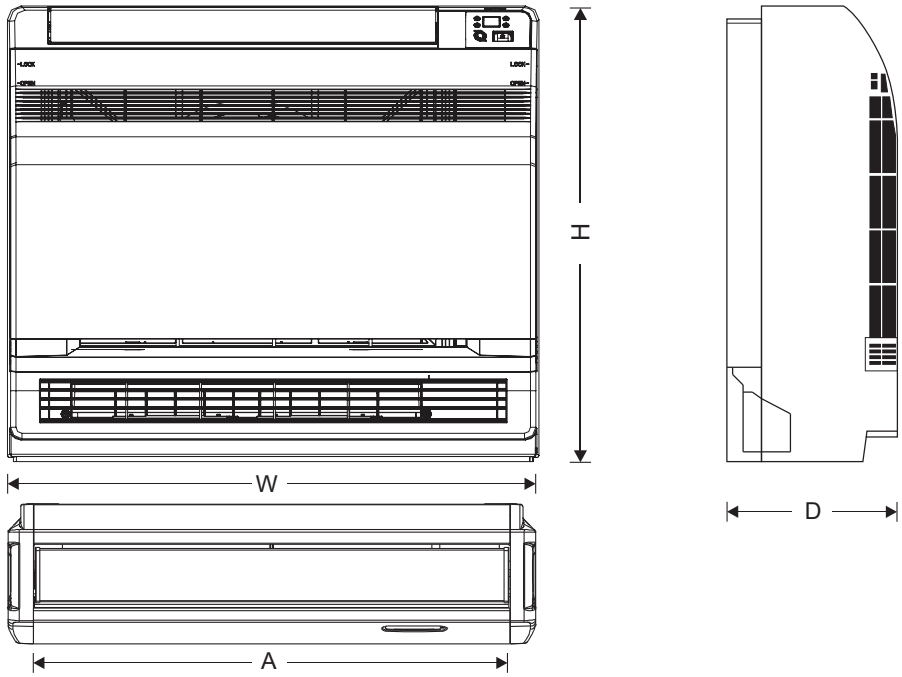

## CLEARANCE

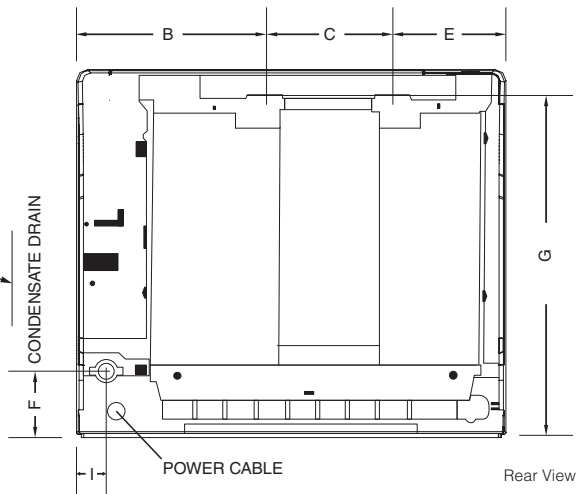
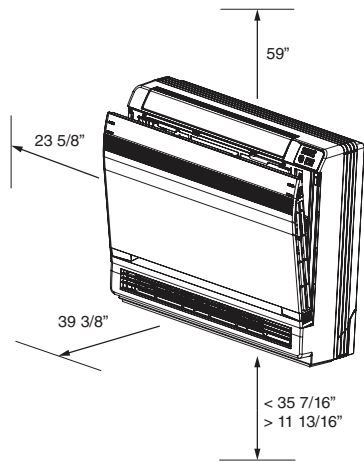

## TERMINAL BLOCK

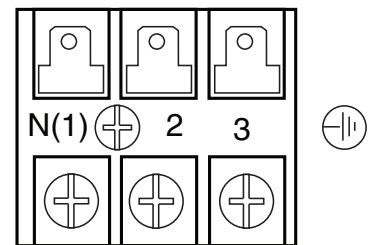

## FEATURES

- 208-230/1/60 power input
- Quiet and efficient heating & cooling.
- Wide working ambient temperature ranges
- Stylish design
- Built in protection functions
- Selectable top and bottom discharge air vent
- Removable Washable Filter
- Durable ABS cabinet
- Standard flare brass connection valves
- Built to ETL/UL/CSA/AHRI standards
- Easy installation and convenient maintenance

**YMGI Group**  
 601 Arrow Ln, O'Fallon, Missouri 63366  
 Phone: 1-866-833-3138  
 Fax: 1-866-377-3355  
 ymgigroup.com

Sales Representative or Distributor: