



Submittal Data Sheet: FB080A/FB110A Models

**CEILING MOUNTED
EXHAUST FAN**



FB080A/FB110A Models

Options:

- TIMER DELAY
- HUMIDITY SENSOR
- MOTION SENSOR
- SPEAKER

Applications include:

- Bathrooms
- Kitchens

Job Name:		Tag #:	
Location		Date:	
Engineer:		Approval:	
Submitted to:		Unit #:	
Submitted by:		Drawing #:	
Reference		PO #:	

FB Series

Exhaust Fan Features:

- **Motor**
Enclosed well balanced brushless DC (024 models) or permanent-split-capacitor (PSC) motor (115 models) with ball bearing of life time lubrication.
- **Blower Wheel**
Polymeric dual-inlet blower wheel balanced and secured onto motor axle with hex nut.
- **Grille**
Made of ABS with springs for simple installation and easy removal from ceiling.
- **Fan Housing**
Galvanized steel housing coated to help resist against humidity.
- **Duct Collar**
Plastic collar for duct connection with built in non-metallic back draft damper for quiet operation.
- **Sensors**
Optional humidity sensor or motion sensor automatically turns on/off or speed up/down fan for more energy saving.
- **Electrical knock-out**
1/2" for easy wiring access

Easy Installation.

Perfect for New Construction, Retrofits or Replacement of Old Ventilation Fans.

- Ultra Quiet Exhaust Fan
- High Quality Construction
- Spring Mounted Front Panel
- Compact Design
- Easy Installation
- Easy Disassembly
- Easy to Clean

Model	Impeller (mm)	Housing dimensions	Duct size (mm)	Voltage	Frequency	Fan Watt	CFM	Noise (sones)	EER	Package Size
FB080A-A115	150	9" x 9" x 7.8"	100	120/220	50/60	20	80	0.6	4.0	71.0 x 40.5 x 51.5
FB110A-A115	150	9"x 9" x 7.8"	100	220/220	50/60	30	110	1.5	3.5	71.0 x 40.5 x51.5
FB080A-A024	150	9" x 9" x 7.8"	100	24	50/60	20	80	0.6	4.0	71.0 x 40.5 x 51.5
FB110A-A024	150	9"x 9" x 7.8"	100	24	50/60	30	110	1.5	3.5	71.0 x 40.5 x51.5



UPBLAST ROOF FAN

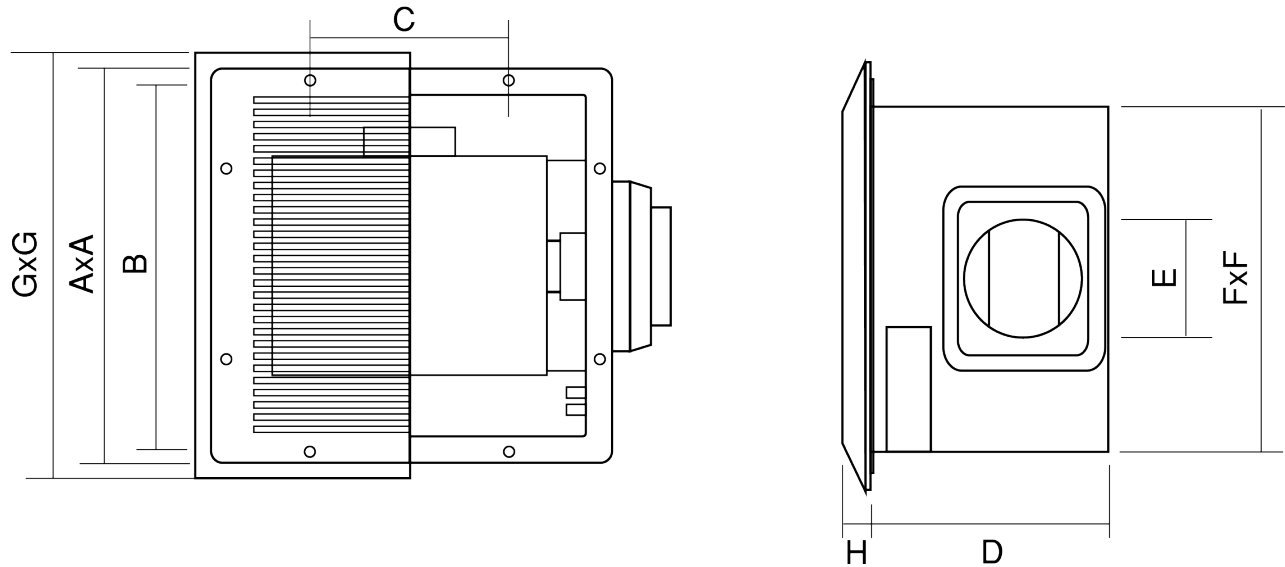

Model	A	B	C	D	E	F	G	H
FB080-A115	270	254	140	198	100	230 x 230	300 x 300	27
FB0110-A115	270	254	140	198	100	230 x 230	300 x 300	27
FB080-A024	270	254	140	198	100	230 x 230	300 x 300	27
FB110-A024	270	254	140	198	100	230 x 230	300 x 300	27

YMGI Model Nomenclature

Model Number:

FB08A-A115L

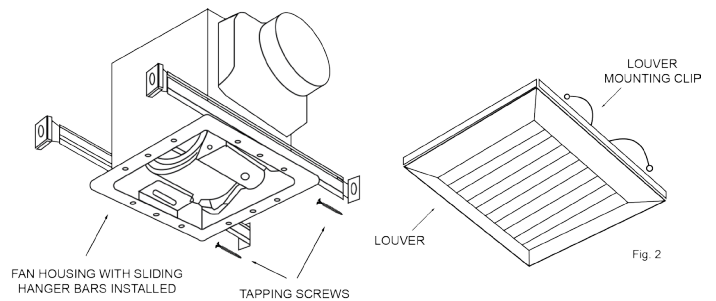
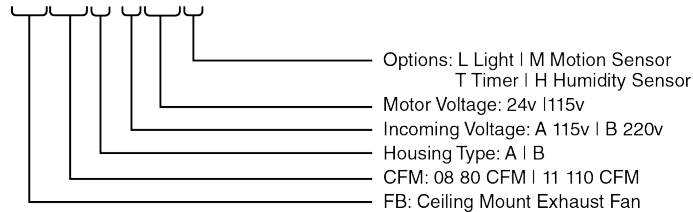

YMGI Group
 601 Arrow Ln, O'Fallon, Missouri 63366
 Phone: 1-866-833-3138
 Fax: 1-866-377-3355
 ymgigroup.com
 sales@ymgigroup.com

Sales Representative or Distributor: