



YMGI, Engineered Comfort Products for A Sustainable and Efficient Green World!

INSTALLATION INSTRUCTIONS & USER MANUAL

DC INVERTER SPLIT TYPE HEAT PUMP (Down to -22°F Ambient) DUCTED INDOOR UNIT UNIVERSAL CABINET (UC)

Model Numbers:

VRUI-24UC-M2B(54)

VRUI-36UC-M2B(54)

VRUI-48UC-M2B(54)

VRUI-60UC-M2B(54)



Thank you for choosing this YMGI product. Please read the owner's manual carefully before installation and operation, and retain for your records and future reference. If you need a replacement copy, please contact your local agent or visit www.ymgigroup.com to download a current electronic version.

NOTICE

This product is designed and manufactured to be free from any defects in material and workmanship during normal use and maintenance. Installation, operation, maintenance and repair must follow all standards and professional practices for regular cooling and heating equipment, such as NEC, State, or Local Codes and all related documents/manuals provided by YMGI. Failure to follow and adhere to all codes and documentation can cause damage to equipment, property even personal injury.

Installer: Currently licensed/certified HVAC technicians only. Must Read the manual and all provided documents prior to installation. Complete and fill out all required information on the warranty registration card.

User: Retain this manual and all supplied documents for your records and future reference.

Service: Use this manual for information concerning servicing and maintenance of this product.

SAFETY WARNING

Only qualified technicians should install and service this equipment. The installation, startup, operation and servicing of this equipment can be hazardous and requires a HVAC professional who has been trained, licensed and certified. Installations, adjustments or any equipment alterations done by an unqualified person could result in serious injury and even death. When working on the equipment, observe all precautions in the provided documents, on the tags, stickers, and labels that are attached to or placed on the equipment.



TABLE OF CONTENTS

Introduction3

Note From YMGI – **Must Read**5

Installing Technician/Contractor's Responsibilities7

Limited Product Warranty8

Limited Product Warranty Registration Card 10

Why Does YMGI Group Require Installation and Service to Be Performed
100% By Currently Licensed or Certified HVAC Technicians/Contractors 11

Suggestions to Aid You in Hiring an HVAC Contractor 11

Introduction to Unitary Systems..... 14

System Diagram 15

Product Introduction 16

Unit Dimensions 17

Specification Sheet 18

General Information 20

Preparing for Installation 20

Important Safety Instructions 21

Recommended Tools for Installation 23

Installation..... 24

Piping Work 25

Condensate Removal 27

Electric Heater..... 28

Electrical Installation 29

Connection of Power and Communication Wires..... 30

Installation Checklist for Trial Run 32

Trial Run 33

Troubleshooting 33

The Following Circumstances are Not Malfunctions 34

Maintenance and Care 35

Heating and Cooling Performance..... 36

User Notes and Installation/Service/Maintenance Notes 40



Introduction

Read this manual carefully, making sure you understand all the instructions, practices and procedures contained in this manual. Be sure you are familiar with all the safety advisories that appear throughout this manual. Your personal safety depends upon your observance of all precautions contained in this manual.

Safety advisories appear throughout this manual and your personal safety and the proper operation of this appliance depend upon the strict observance of these precautions.

The 3 types of advisories are defined in the following table:

⚠ WARNING	Indicates a potentially hazardous situation which if not avoided could result in serious injury or even death.
⚠ CAUTION	Indicates a potentially hazardous situation which, if not avoided, could result in minor or moderate injury. It could also be used to alert against unsafe practices.
NOTICE	Indicates a situation that could result in equipment or property-damage only. It can also be used to call attention to important details within this manual.

Important Environmental Concerns

Studies have shown that certain man-made chemicals can affect the earth's stratospheric ozone layer when released into the atmosphere. Refrigerants that contain Chlorine, Fluorine and Carbon (CFCs) and those containing Hydrogen, Chlorine, Fluorine and Carbon (HCFCs), may affect the ozone layer. Not all refrigerants have the same potential impact on the environment. YMGI Group advocates for the responsible handling of all refrigerants including industry replacements for CFCs such as HCFCs and HFCs.

Responsible Refrigerant Practices

YMGI Group believes that responsible refrigerant practices are important to our customers, the HVAC/R industry and the environment. All HVAC/R technicians who handle refrigerants must be certified. The Federal Clean Air Act (Section 608) sets forth the requirements for handling, reclaiming, recovering and recycling of certain refrigerants, the equipment and tools necessary to perform these service procedures. In addition, some states or municipalities may have additional requirements that must also be adhered to for responsible management of refrigerants. HVAC/R technicians must know the applicable laws and follow them.

Disposal Notice

Do not dispose this product or its components as unsorted municipal waste, as they contain items that may require special treatment. Contact your local waste management company for details.

⚠ WARNING

Proper Field Wiring and Grounding Required!

Failure to follow established electrical codes can result in death, serious personal injury and property damage. All field wiring **MUST** be performed by qualified personnel. Improperly installed and grounded field wiring poses **FIRE** and **ELECTROCUTION** hazards. To avoid these hazards, you **MUST** follow the requirements for field wiring installation and grounding as described in this manual and by NEC and your state and local electrical codes.

⚠ WARNING

Personal Protective Equipment (PPE) Required!

Failure to wear proper PPE for the job being undertaken could result in serious injury or even death. Technicians must take the necessary precautions to protect themselves from potential electrical, mechanical, and chemical hazards and **MUST** follow all precautions in this manual and on the tags, stickers, and labels, as well as the instructions below:

- Before installing or servicing this unit, technicians **MUST** put on all PPE recommended for the work being undertaken. **ALWAYS** refer to appropriate Material Safety Data Sheets (MSDS) and Occupational Safety and Health Administration (OSHA) guidelines for proper PPE.
- When working with or around hazardous chemicals, **ALWAYS** refer to the appropriate MSDS sheets and OSHA guidelines for information on allowable personal exposure levels, proper respiratory protection, and handling recommendations.

If there is a risk of arc or flash, technicians **MUST** put on all PPE in accordance with NFPA 70E or other country-specific requirements for arc flash protection, **PRIOR** to servicing the unit.



Copyright

This document and the information contained therein are the sole property of YMGI Group and shall not be used or reproduced in whole or in part, without the written permission of YMGI Group. YMGI Group reserves the right to revise this manual at any time and to make changes to its content without obligation to notify anyone about any modifications, revisions or changes.

⚠ WARNING

- Instructions for installation and use of this product are provided by the manufacturer.
- Installation must be performed by authorized and licensed personnel only and in accordance with all the requirements of this manual, the NEC, CEC and any state and local codes.
- For safe operation of this unit, please read and follow all instructions carefully.
- The total operation capacity of the indoor units should not exceed 120% of the total capacity of the outdoor units if all indoor units must operate at their peak capacities all the time. Otherwise, the heating and cooling operation will be diminished and less efficient which could damage the units.
- Any person responsible for system operation or system maintenance should retain this manual for reference.
- If the unit fails to operate normally, please contact your authorized system installer or HVAC professional as soon as possible and provide the following information:
 - Data on the unit (model number, serial number and owner's name).
 - A detailed description of the unit's problem before and after the problem occurred.
- To avoid personal injury or property damage, do not disassemble the unit yourself. If disassembly is required to check the unit, contact your authorized system installer or HVAC professional as they have the experience and training necessary to perform this task.

Note: Each unit has been thoroughly tested to ensure it operates correctly before leaving the factory.

Basic Cautions and Warnings

⚠ CAUTION

All units shall be installed by an experienced HVAC licensed contractor or technician. Read all manuals before installation, startup and operation.

⚠ CAUTION

All NEC, state, local codes and installation instructions must be followed for all units, otherwise, the unit warranty will be void and could result in serious damage to people or property.

⚠ WARNING

YMGI Group is not responsible for any damage or loss due to Do-It-Yourself (DIY), self-installation or any improper installation, improper operation, improper service or natural disasters of any kind.

⚠ WARNING

Do not connect power to the unit until all wiring, tubing and all unit inspections and testing have been completed. Ground the unit according to the instructions and adhering to NEC, state and local codes.

⚠ WARNING

All wiring connections must be correct and secure. Loose wire(s) or improper contacts may cause arcs or overheating which can result in a fire hazard.





Note From YMGI – Must Read

Dear Customers, Purchasers, Installers, and Contractors

Thank you for choosing an YMGI product.

All YMGI's products are fully tested and have passed rigorous safety, performance and manufacturing standards before being packed and shipped. YMGI only uses suppliers that meet our strict standards for high quality and performance for all parts. YMGI also recognizes a quality installation is equally important therefore your system must be installed by a licensed HVAC professional. A quality installation ensures your unit will operate at its highest efficiency and peak performance for many years of worry free comfort; while a poor installation can result in unit failure and cause the unit to operate inefficiently, either immediately or over time, resulting in costly repairs.

Because a quality installation is so critical, YMGI provides detailed information in our manuals which will aid the installing technician and the owner of the unit(s).

At YMGI our goal is to ensure that your YMGI units are installed properly and correctly from the beginning.

The YMGI equipment you purchased is either a split-type or a self-contained cooling/heating system. These types of systems require a certified and licensed HVAC professional technician for proper installation. Only a certified and licensed HVAC professional technician will have the knowledge, experience, and attention for all required details to perform a complete and successful installation. This equipment is different from a window or portable type air conditioners you can purchase from local retail stores such as Home Depot, Lowe's, Sears, etc. which the manufacturer may not require certified and licensed personnel to install.

Reading and following YMGI Group recommendations and requirements contained in the following pages and other documents, is the first step to help ensure a smooth installation and proper operation of your unit for many years.

⚠WARNING

YMGI doesn't recommend nor allow any do-it-yourself (DIY) installation (partially or fully). Due to the complexity of the installation of this product most DIY installations usually have problems, either immediate or near future. These problems can cost more to fix than any upfront savings. **YMGI warranty doesn't cover any DIY units.**

If you have any questions about your unit or if the unit has a problem, you should first check the manual. If you can't find a solution, then contact your local installer or service technician to schedule a service appointment. The technician can physically inspect the unit. If at the time of inspection, the installer or service technician has any questions about the unit, they can contact YMGI technical support division directly at:

Toll Free Number: (866)833-3138 or Email: techsp@ymgigroup.com

IMPORTANT: YMGI Group is the MEDIA AUTHORITY:

YMGI Group, located in O'Fallon, MO 63366 is the author of all media produced for its products and is the only party able to give any additional explanation for any data, definitions and or descriptions found within any of its media, including but not limited to YMGI product brochures, manuals, pamphlets, catalogs, and videos. YMGI's distributors, installers, dealers, agents, customers or any other third parties will not supersede YMGI in anyway concerning YMGI-published materials and their meaning. Any concerns or questions arising from YMGI distributors, installers, dealers, agents, customers or any other third parties, should be presented directly to YMGI. YMGI will respond to any concerns or questions, if necessary, about any of its media in writing.





NOTICE

- Be sure to only hire a certified and currently licensed HVAC Company to complete 100% of the installation so that all details of the installation are performed correctly and completely.
- Be sure to have ONLY the licensed HVAC professional perform all aspects of the installation. Factory Warranty will be void if any portion of the installation is not performed by a licensed HVAC contractor/technician. DIY or partial DIY will also void ALL factory warranties.
- When hiring an HVAC technician that is offering their services as a "side job" and not hiring a licensed HVAC company may pose possible risk. This may result in an incomplete or unsatisfactory installation, no guarantee for workmanship and lack of maintenance and further service to your unit.
- Have the installation technician read in full the installation manual and all supplied documents for the product model you purchased. Details within the documentation contributes greatly to the success and quality of the installation. Experience with other manufacturers may not be applied fully to another manufacturer, although there will be similarities there will also be differences. Ignoring the provided installation procedures is an act of negligence and may cause unit failure or damage which could be irrevocable and permanent.
- It is possible for a licensed contractor/technician to make a mistake during the installation. YMGI doesn't supervise nor is able to control the contractor/technician's installation. It is critical that the installer take each variable into account during the initial installation. This will ensure a complete and professional installation and that all units work properly.

⚠WARNING

The following will damage the unit and its key components resulting in loss of factory warranty:

1. Any foreign substances introduced into the system because of failure to seal the ends of the refrigeration piping before pulling the piping through any structures at time of installation.
2. Not installing an oil P-trap in the copper suction line where the indoor unit is located 18 feet or more below the outdoor unit.
3. Cross piping and/or cross wiring of any units including more than one single zone or a multi zone system.
4. Not conducting a positive leak check prior to the negative leak check.
5. Not conducting a positive leak check by charging the system with dry-nitrogen 350 PSI to hold for 3+ hours, and performing soap bubble testing.
6. Not conducting a negative leak check by evacuating the copper lines for 30 minutes for each zone. Vacuum must be held at 500 microns or better for at least 60 minutes, starting 60-minute timer after the vacuum pump is turned off.
7. Not selecting the correct size of wire or circuit breaker.
8. Not answering ALL questions in the technician's checklist located inside the warranty registration form.

⚠WARNING

The following may be overlooked, ignored, or considered unimportant during your installer's installation, but will cause your unit to underperform and may cause unit failure.

1. Any kinks in or improper bending of the copper piping.
2. Any poorly formed flares or not centering the flare with the flare nut, or not tightening all connections.
3. Not testing each indoor unit individually.
4. Not reading technical data (temp/time/pressure/current) after the system is stabilized (normally the compressor needs to run at least 10 minutes before reading the data). If the data is read too early may lead to inaccurate assessments about the unit.

In an effort to help protect our customers from possible faulty installations that can lead to premature unit failure, YMGI provides the above information for you and the technician. You can observe while your system is being installed, even though your observation is not a guarantee your system is being or has been installed properly and professionally. With the information provided above, you will know some things to look for and questions you can ask. If at any time you feel there may be an issue with the installation, please have your technician contact YMGI at (866)833-3138 x 703 with any questions, issues or concerns you may have.





INSTALLING TECHNICIAN/CONTRACTOR'S RESPONSIBILITIES

1. Discuss with the customer detailed information about the structure to be conditioned, local weather (typical design, extreme temperature/humidity conditions, cooling and heating hours), previous and existing HVAC equipment (if any), usage and dependence on new HVAC equipment or YMGI products.
2. Performing a cooling/heating load calculation by using commercially available professional programs/methods such as Right-J (Manual J) for residential HVAC applications and Right-CommLoad (ASHRAE RTS/CLTD) for light commercial and commercial HVAC applications.
3. Contact your YMGI distributor/sales department or contact the manufacturer directly to obtain additional information to fully understand your YMGI products, including but not limited to product features, cooling/heating performance at standard ratings/conditions and extreme conditions, allowed indoor and outdoor temperature and humidity ranges, installation, operation, maintenance, service, warranty, parts and any other issues pertaining to YMGI products.
4. Select the correct (most suitable) YMGI product unit models and accessories necessary for your HVAC applications and list them in the proposal/quote, in writing, on company's quotation form or letter head, based upon the information you collected from 1), 2) and 3).
5. List your currently valid HVAC license number and EPA number in your proposal/quote.
6. Make sure you are the only party to perform the entire installation and you will not sub-contract any part of the installation to any non-licensed parties or persons. You will be solely responsible for the entire installation that you have been contracted.
7. Make sure you have all the materials you need to properly, completely and correctly finish the installation. The YMGI units and accessories may be just a portion of what you will need for the project. When support issues arise, remember YMGI employees and YMGI distributors/sales, dealers and agents are not installers and may only provide suggestions. You are the only decision maker to determine what other materials you need to complete the installation.
8. When connecting electrical wires, follow all NEC, state and local codes and ensure the installation of all YMGI units and accessories meet these requirements.
9. Connect the unit to a correctly sized electrical power source. If the unit is installed in an area where lightning or storms occur frequently, a correctly sized and type of power surge protector must be installed between the outdoor unit and the power source.
10. Select the correct types and sizes of HVAC circuit breakers, disconnect switch boxes, wires and conduit from circuit breaker to disconnect box and then from disconnect box to outdoor unit.
11. Select the proper location for installing indoor units and outdoor units with all factory requirements being followed (cooling/heating air inlets and outlets are not blocked or restricted, mounting structure is secure, installation for convenience is considered, allow adequate clearance for maintenance/service and all applicable codes are met).
12. Cap/tape the two ends of every copper line before running them through any structure to keep any foreign substances from entering the pipe causing contamination. Label them A-A, B-B, C-C, D-D, or any other identifying marks on each pair of copper lines and wiring cable sets to keep from cross-piping or cross-wiring in multiple zone installations or where pipes for different single zone systems are close to one another.
13. Secure the wiring cables that connect between the indoor unit and outdoor unit, following all applicable NEC, state and local codes for your installation. If there is no special NEC, state or local codes to govern how these wires are to be installed, you can tape/cable tie them along with insulated copper line.
14. Tighten all pipe and wire connections ensuring there is no leakage or false connections.
15. Conduct a positive pressure leakage test, checking each of the inter-connecting copper lines between each indoor unit and outdoor unit by charging with dry-nitrogen at the outdoor unit's service port (note: do not back-seat stopping valve). A liquid soap solution shall be applied at all pipe connections to check for leakage. A 1/4" - 5/16" hose/valve adaptor may be needed if you have a 1/4" traditional manifold hose connection.
16. If there is no positive leaking, then conduct a negative pressure leakage test, checking all inter-connecting copper lines between each indoor unit and outdoor unit by pulling vacuum at the outdoor unit's service port (note: do not back-seat stopping valve) and checking that the vacuum level of 500 Microns can be held for at least 60 minutes.
17. If there is no leakage found at any of the refrigeration pipe connections, flip up the indoor unit's face panel and remove filter, carefully pour some clear water onto the up-right aluminum coil surface to test if the water can drain out of each the indoor unit's freely without finding any leakage.
18. If there is water leakage found, locate the source of the leak and correct it. Only after everything is clear, engage the correct electrical power to the system.
19. Then back-seat stopping valves of the outdoor unit to release refrigerant from the outdoor unit into the inter-connecting pipes and indoor unit.
20. Make sure both the indoor unit and outdoor unit are powered on correctly, operating the indoor unit in fan mode first. Then move on to test cooling, dehumidifying/drying, heating and other modes.
21. Read refrigerant pressures and pipe/valve temperatures only after the system is stabilized (normally 10 minutes after cooling/heating mode is started successfully). Record this data into the technician checklist in the lower half section of the Limited Product Warranty Registration Card/Form.
22. Adjust refrigerant charging level (remove refrigerant if pipe is shorter, the temperature is colder; add refrigerant if pipe is longer the temperature is warmer), following the manufacturer's instructions. If the average pipe length is shorter or longer than 25' and pressure/temperature readings at the outdoor unit service valves are not falling into normal ranges.
23. Explain to the user/owner about proper unit operation and maintenance. Leave your contact information to allow them to reach you. If the customer finds the unit doesn't work properly and cannot resolve the issue themselves, check the customer's units/parts/accessories and correct the issue if there is one. Communicate with YMGI-technical support line at (866)833-3138 x 703, if further help necessary.

Following these requirements will aid in ensuring that the units to be installed meet general HVAC practicing standards and necessary factory requirements. Finding any possible problems early, preventing any further damage to the unit will help to ensure a properly working unit for many years.





LIMITED PRODUCT WARRANTY

Once the installation and successful testing of the system has been completely performed by a qualified licensed/certified HVAC technician/contractor, the registration card/form is filled out completely and correctly, and filed along with a valid installation invoice from the contractor within 7 days of the original installation, the following standard **Limited Product Warranty** is qualified: **7-years** on the **compressor** and **2-year** on **PARTS ONLY**. There is **no labor coverage**.

YMGI products are designed and manufactured free from defects in workmanship, and materials for normal use. However, if for any reason, including occasionally transporting between YMGI factories/warehouses and your delivery location, you discover the unit has issues, YMGI Group will help field a solution by following YMGI's established warranty procedures:

Compressor: YMGI will warrant the compressor of an YMGI-validated and approved warranty filing, for a period of 7 years from the date of successful installation at its original installation location.

Parts: YMGI will warrant parts of an YMGI-validated and approved warranty filing, for two years from the date of successful installation at original installation location.

All warranty compressors and parts replaced will become the sole property of YMGI Group and must be returned to YMGI Group upon request. Warranty parts may be new or refurbished. All parts are tested and approved before shipping.

At no time does YMGI Group warrant labor cost of any type. Warranty will start from the date of successful installation at original installation location, or 90 days as of original shipping date from YMGI Group, whichever comes first.

This is a standard limited liability warranty and DOES NOT cover the following:

- Any damage or repairs to properties, or persons as an incident of or consequence of improper faulty transportation, installation, operation, maintenance or service.
- Any damage caused by frozen or broken water hoses or refrigeration pipes in the event of equipment failure.
- Any damage due to floods, fire, wind, lightening, accidents, corrosive atmosphere or any other conditions beyond the control of YMGI Group.
- Any damage due to interruption or inadequate electrical service to equipment.
- Any products that are installed outside the US or Canada.
- Any unit that has been moved from its original installation address.
- Any labor costs associated with the installation or service of the unit.
- Poor unit performance due to improper unit selection (SEER, Unit size).

To validate the above warranties, ALL of the following conditions must all be fulfilled:

1. The unit was fully (100%) and successfully installed by a licensed or certified HVAC technician.
2. The unit was installed following all NEC, state and local codes.
3. The unit was installed following all the information within the Instructions and User Manuals provided by YMGI Group.
4. ALL fields, especially the technician-checklist, of the **Limited Warranty Registration Card/Form** were filled completely by the installing technician and signed by both the installing company technician and the unit owner.
5. The **Limited Warranty Registration Card/Form** and a copy of the original installing company's invoice have been received by YMGI Group-Warranty Dept., POB 1559, O'Fallon, MO 63366, within 7 days of successful installation.

**No warranty filing will be validated or approved, if any one of the above conditions are not met.
Product registration doesn't guarantee the validity of this limited warranty statement.**





Steps to follow for warranty part replacement:

1. The installing or service technician must contact YMGI tech support at 1-866-833-3138 ext. 703 from the installation location to check and confirm with YMGI Technical support the exact part(s) needed to fix the problem(s).
2. YMGI will check the customer's warranty filing. There will be no charge for Parts with a validated and approved warranty. Any Parts that have not been validated and approved or have an invalid warranty filing resulting in an unapproved warranty request, will be charged accordingly.
3. ***YMGI will ground ship out the parts ASAP. Expedited shipping is available at the customer's expense.***
4. Replacement parts that have an approved warranty registration are to be warranted for the remainder of the 2-year on parts and a 7-year compressor warranty. Purchasing of replacement parts without a valid warranty filing or unapproved warranty request, will be sold as is and are not covered by any warranty.

YMGI is continually improving products with various engineering changes and these changes are made without prior notice. Such improvements or changes include but are not limited to product specification, appearance, functionality, size, packaging, etc. These improvements or changes will not void the limited warranty stated herein. YMGI is the final authority concerning this warranty policy.





LIMITED PRODUCT WARRANTY REGISTRATION FORM

Top Portion and Keep Copy A is for YMGI Internal records. Copy B is for Installer to Fill out and Mail back to YMGI. Bottom Copy C for Customer records.

For YMGI Use Only	Date:	Shipping Packing List Number:	Registration Card Serial No.
	Did the Company Pay YMGI:	Unit(s) Work Successfully:	Yes/No
	Installation Invoice Attached to the Registration Card	Hired YMGI Recommended HVAC Contractor/Technician?	Warranty Approved
Outdoor Unit Serial Number :		Indoor Unit Serial Numbers:	Unit 1 Unit 2 Unit 3 Unit 4 Unit 5
			Unit 6 Unit 7 Unit 8 Unit 9 Unit 10

Contact at Installation Location:

Name:	Phone:	Fax:
Address:	Email:	
City:	State (Province):	Country:

Contact of the Installing HVAC Contractor/Technician:

Technician Full Name (Print):	Phone:	Fax:
HVAC Technician's Company:	Email:	
Company Address:	City:	State (Province):
Currently Licensed/Certified HVAC Technician License or Certification Number:	License Approved/Certified by:	
Official Phone # to Check the License Validity:		

Checklist for Installing HVAC Technician to Verify Installation Quality, and for Warranty Processing Purpose (If not filled out completely by technician, warranty will be voided)

1) Did you install the whole system? If not, please note below.	15) Where is the outdoor unit located? Ground wall balcony roof other location or pad	Is the outdoor unit anchored to ground or secured onto wall bracket? Yes No
2) What had been done, prior to your arrival?	16) Have you checked to make sure there is no cross-piping and/or cross-wiring between any two indoor units (zones)? What was your procedure?	
3) Did you read the User Manual and Installation Instructions before starting the installation?	17) Were the refrigerant pipe ends capped or sealed, prior to running them through structures to keep debris from entering the copper lines?	
4) Who unpacked the unit and accessory boxes to check for damage?	18) Have you checked both cooling and heating on all indoor units individually to ensure proper function?	
5) Supply electrical power V/Ph/Hz measured at wiring terminal block of Indoor unit: Outdoor unit:	19) Did you charge the inter-connecting copper pipes and indoor unit with nitrogen to check for positive leakage (pressures 150-200PSI), before conducting a vacuum leak check?	
6) Incoming electrical power V/Ph/Hz measured at terminal blocks of Indoor unit: Outdoor unit:	20) Did you vacuum correctly to check the connecting pipes and indoor unit for leakage? What was the micron gauge reading, for how many minutes?	
7) Wire gauge, length and terminal colors between circuit breaker/disconnect switch to outdoor unit:	21) Did you check the compressor's start and stop sequences to determine proper functionality?	
8) Wire gauge, length and terminal colors between each indoor and outdoor unit: Unit A Unit B Unit C Unit D	22) If copper length were not made to the supplied or recommended refrigerant pipe length, how much refrigerant added or deducted?	
9) The size of HVAC circuit breaker/fuse or disconnect switch to the outdoor unit:	23) Measured refrigerant pressures at outdoor service suction valve, when unit was stabilized. Heat pump (PSI): Cooling (PSI): Outdoor Ambient Temp. (°F):	
10) Are the inter-connecting wires and copper lines between indoor and outdoor units installed/covered/protected by line set covers, or anything else?	24) What were the measured temperatures (probe not touching any metal): At cooling: indoor return air °F Discharge air °F and outdoor °F At heating: indoor return air °F Discharge air °F and outdoor °F	
11) What is the refrigerant pipe length between each indoor unit and the outdoor unit? Unit A Unit B Unit C Unit D	25) Have you checked all unit functions with customer present, and all functions are working correctly?	
12) Where is/are the indoor unit(s) located? (Bedroom, kitchen, etc.) Unit A Unit B Unit C Unit D	26) Did you show the user how to operate the unit? Did he/she understand you?	
13) What is the elevation difference between each indoor unit and the outdoor unit? Unit A Unit B Unit C Unit D	27) Do you provide regular one-year free technical service for this installation?	
14) Did you check the indoor unit for condensate leakage and refrigerant leakage, before and after connecting them? Yes No	28) Do you list the working details in the invoice and leave a copy to the customer? Yes No	

Installation Finished and Unit Works Successfully. Print Name of Installation HVAC Technician: Signature: Date and time:	Installation Finished and Unit Works Successfully. Print Name of Owner: Signature: Date and time:
---	--

By signing above, I acknowledge the liability and responsibility for any false statement or omission of facts, and I authorize YMGI to verify the details provided above, and make its decision on warranty. I understand our filing or filling out of the warranty card/form DOES NOT imply automatic warranty approval, because warranty is approved only to qualified and successful installations by a qualified HVAC technician. I understand that the warranty (if approved) is a standard 5 year compressor and 1 year parts only, and does not include any labor coverage. I agree to and will follow all the contents contained in the Limited Product Warranty Policy of YMGI, and no other entity, stated in public, including but not limited to manuals, web site, email, etc.

Important Note: A copy of the installing HVAC company's invoice to show all their work details, your payment proof, center copy B of this registration card filled out after a successful installation, all three (3) MUST be mailed together to Warranty Dept., YMGI Group, POB 1559, O'Fallon, MO 63366, for warranty processing. Customer keeps bottom copy C. YMGI will check against copy A that was kept at YMGI.





WHY DOES YMGI GROUP REQUIRE INSTALLATION AND SERVICE TO BE PERFORMED 100% BY CURRENTLY LICENSED OR CERTIFIED HVAC TECHNICIANS/CONTRACTORS?

1. Expertise and Safety:

They have the training and experience to accurately and safely install and service your equipment. The equipment runs with high-pressure refrigerant, oil and electrical current. The copper lines must be installed properly to prevent leakage and foreign substances from contaminating the refrigerant system.

2. You will save money in the long run:

If any problem occurs with the unit that has been fully installed by a currently licensed or certified technician/contractor, contact the original licensed or certified HVAC technician to evaluate the unit as they have the training and experience to correct the problem quickly and efficiently. A technician may be unwilling to repair an issue on a unit that they did not install. If you do find a technician willing to perform this service, there is an increased possibility of higher service fees, increased service visits, or delayed service from that technician.

3. It's the law!

The federal, state and/or local government and authorities have various governing laws or regulations, guidelines, ordinances, etc. These laws may require only licensed or certified professionals can install and service this type of high pressure HVAC equipment.

SUGGESTIONS TO AID YOU IN HIRING AN HVAC CONTRACTOR:

1. Hire a currently practicing, licensed/certified HVAC professional technician/contractor. Technicians, who are no longer practicing (retired, etc.) in this field, may not have current technical knowledge or may lack experience on the equipment you have purchased.
2. Hiring a licensed technician to install your unit as a "side job" and not hiring a licensed HVAC company may pose possible risk. This may result in an incomplete or unsatisfactory installation, no guarantee for workmanship and lack of maintenance and further service to your unit.
3. Hire a technician/contractor who services customers in your local area and one you are familiar with. Local contractors have a faster response time and it will be easier for you to determine if they are reputable.
4. Use only a reputable licensed/certified HVAC installation professional to prevent any unexpected charges because of unethical business practices.
5. Check their references, verify they provide professional service for their customers. N.A.T.E or A.C.C.A certified technicians are strongly recommended.
6. Some contractors/technicians may not feel comfortable about installing equipment that has been purchased by someone other than themselves. They prefer to purchase and install the equipment themselves. You can contact YMGI directly to check and see if there are contractors in your area who have installed our products or any similar products.
7. Ask for a detailed quote for the complete installation project. A flat rate quote is the safest contract for both you and the contractor.
8. Local HVAC technicians may charge you on a project basis or on an hourly basis. It has been our general experience; **a full single head installation normally can cost \$800 to \$1500**. These costs are estimates, and your actual costs may differ due to your specific job requirements and installation location.
9. Number of hours can vary depending upon each individual situation, some factors are, but not limited to:
 - Difficulty or complexity of securely installing the indoor unit.
 - Difficulty or length of the inter-connecting pipes and wires to be installed.
10. A successful installation is dependent on all these suggestions and all the necessary steps are followed.
11. If the contractor(s)/technician(s) are experienced with the systems/brands you purchased. **You might save on the installation cost, but remember to always ask for and verify references.**
12. The contracts should list and detail all work to be performed and the standards they will follow. Some contractors are willing to include a 1-year installation/service warranty at no extra charge. Check to see if this is an available option. If available, make sure it is included in the contract.
13. Verify and confirm the installation is completed and all the unit functions have been tested and working properly. All items on the checklist should be checked and clearly marked in the warranty registration card/form, prior to paying the contractor in full.

The cost of not having your unit professionally installed can be more expensive than the additional cost of hiring a certified contractor. Protect your investment and warranty eligibility by doing it right the first time.



⚠ WARNING**Safety Precautions**

1. Follow these instructions to complete the necessary installation process. Carefully read this manual before installation and unit startup or servicing.
2. Wire size of power cord should be properly sized to meet the required electrical loads. Should the power cord get damaged, the power cord should be replaced with a manufacturer approved cable.
3. After connecting the power cord, attach the electric box cover and secure properly.
4. Always meet the nitrogen charge requirements when welding pipes.
5. Never short-circuit or cancel the pressure switch as this will result in damage to the unit.
6. Connect the wired controller before energizing, otherwise the wired controller cannot be used.
7. Before using the unit, verify the piping and wiring are correct. This will avoid water leakage, refrigerant leakage, electric shock, or fire etc.
8. Do not insert fingers or objects into the air outlet or inlet grille.
9. Open a door or window for ventilation for allowing fresh air to enter the room to avoid depleting the oxygen while gas/oil supplied heating equipment is used during the installation.
10. Never start up or shut off the unit by means of directly plugging into or unplugging the power cord from the power outlet.
11. Turn off the unit after it runs at least five minutes, otherwise it will influence the oil return of the compressor.
12. Do not allow children to operate this unit.
13. Do not operate this unit with wet hands.
14. Turn off the unit or disconnect the power supply before cleaning the unit. This will avoid possible electric shock or personnel injury.
15. Never spray or splash water towards the unit. This can cause a malfunction in the unit or can result in electric shock.
16. Do not expose the unit to moist or corrosive environments.
17. While operating in cooling mode, do not set the indoor unit's room temperature too low. Keeping the temperature difference between indoor and outdoor unit within 41°F.
18. YMGI Group recommends that only properly trained and authorized personnel be allowed to repair or service the unit. Improper repairs or servicing can result in electric shock or fire hazards. Please contact YMGI Group if you need help locating a qualified repair or service technician.
19. Before installation, check the power supply to ensure it is sufficient to meet and is in accordance with the requirements specified on the nameplate of the unit. Ensure the power overload is functioning correctly and make sure it is properly maintained.
20. Installation must be performed only by an authorized installer or HVAC professional in accordance with the requirements set by the NEC and CEC. Do not attempt to install the unit yourself. Improper handling may result in water leakage, electric shock, fire, and voiding of the warranty.
21. Be sure to use only approved accessories and parts to prevent water leakage, electric shock and fire.
22. Make sure the unit is grounded properly prior to connecting to power source, to avoid electric shock. Do not connect the ground wire to a gas pipe, water pipe, lightning rod or telephone line.
23. Energize the unit for 8 hours before operation. Turn off or disconnect the power within 24 hours to prevent short-cycling (to protect the compressor).
24. If refrigerant leakage happens in a confined space during installation, ventilate immediately. Poisonous gases can occur if the refrigerant gas is exposed to fire.
25. Volatile liquids, such as paint thinners or solvents if exposed to the unit's surface will cause damage to the surface finish. Only use a soft cloth along with a mild non-abrasive detergent to clean the outer casing of the unit.
26. If the unit does not operate normally or if you notice any type of burning odor, power off the unit and turn off the main power supply, then immediately contact your YMGI authorized repair service center or HVAC professional.

NOTICE

YMGI Group will not be responsible for any personal injury or any property damage caused by improper or incorrect installation, improper service or maintenance or by not following the instructions listed in this manual.

DO NOT pull on the power supply cords or refrigeration lines that are connected to the indoor and outdoor units. Install the power supply cords and secure them into position. PVC line set cover is recommended for the outdoor unit to protect against rain, sunlight and accidental damage.

DO NOT allow cold air to blow directly onto people for a prolonged period, as this could make people cold and uncomfortable.

DO NOT undersize any of the power supply wires.

DO NOT connect several units to a single breaker. Don't undersize or oversize the circuit breaker. A poorly sized circuit breaker can cause unit failure and even fire.

DO NOT wire or open a unit while the unit is running. Make sure to disconnect the power supply and switch off all circuits prior to inspecting or servicing the unit. Inspecting and servicing the unit while the power supply is connected, and the circuits are switched on could cause an electrical shock or fire.

DO NOT install the indoor unit near any cooking surfaces, in direct sunlight or any ventilation systems. Poor placement could decrease efficiency and waste energy.

DO NOT install the unit in places where there is exposure to flammable materials or gas.

DO NOT apply chemical solvents, flammable insecticides, or abrasive materials directly on the unit. Clean the unit only with a soft dry cloth.

DO NOT install the unit in a damp laundry room or near flammable gas. All units must be protected by a certified electrical circuit breaker in accordance with all safety and electrical codes.

DO NOT use the system for anything other than what it was designed.

DO NOT store or install the units near food, paint, or other chemicals.

DO NOT use the unit in cool or dry mode for prolonged periods where humidity is higher than 90%.

DO NOT operate the unit for prolonged periods without refreshing ambient air. Open a door or window periodically to allow in fresh air.

BRIEF INTRODUCTION TO UNITARY -22° F HEAT PUMP SYSTEM

The Unitary Heat Pump System is designed for high performance, easy installation and service. Each system consists of one indoor units and one outdoor unit, which are connected by one set of interconnecting refrigerant pipes and electric wires.

As shown in the following sample picture of outdoor unit, air is drawn through the coil from the rear side and then discharged from the front side. In cooling mode, air passing through coil is heated; in heating mode, air passing through coil is cooled.



Sample Unitary Heat Pump System

(Due to engineering and production improvements, unit appearance subject to change without prior notice)

Outdoor unit(s) provides the electrical and thermal power for the whole system. Electrical and thermal components such as compressors and motors and heat exchange coils and others, are incorporated into the cabinet in an optimized order. They can be either hung on the wall or installed on the ground. Once stacking or bracket kit is used, some outdoor units can be stacked 2 or 3 units high, depending upon unit size and applications. Air is discharged horizontally, quietly and smoothly. These units are a perfect fit in locations where installation and applications of general up-flow condensing units are limited, such as apartments, condos, lofts, multi-families and high-rise buildings and others named or unnamed.

Indoor unit(s) delivers the thermal and acoustical comfort to the rooms. Air is drawn through the coil from bottom and then discharged from the top into the ventilation ducts. In cooling mode, air passing through coil is cooled; in heating mode, air passing through coil is heated. Air is filtered or treated by the built in filter (washable or enzyme equipped or electrostatic powered filter, varies from model to model), before being delivered to the air registers.



Apartments



Offices, Restaurants, Gyms, etc.



Homes

These units are designed for applications at:

- Residential
- Institutional
- Commercial
- Light commercial
- Industrial
- Hospital

System Diagram

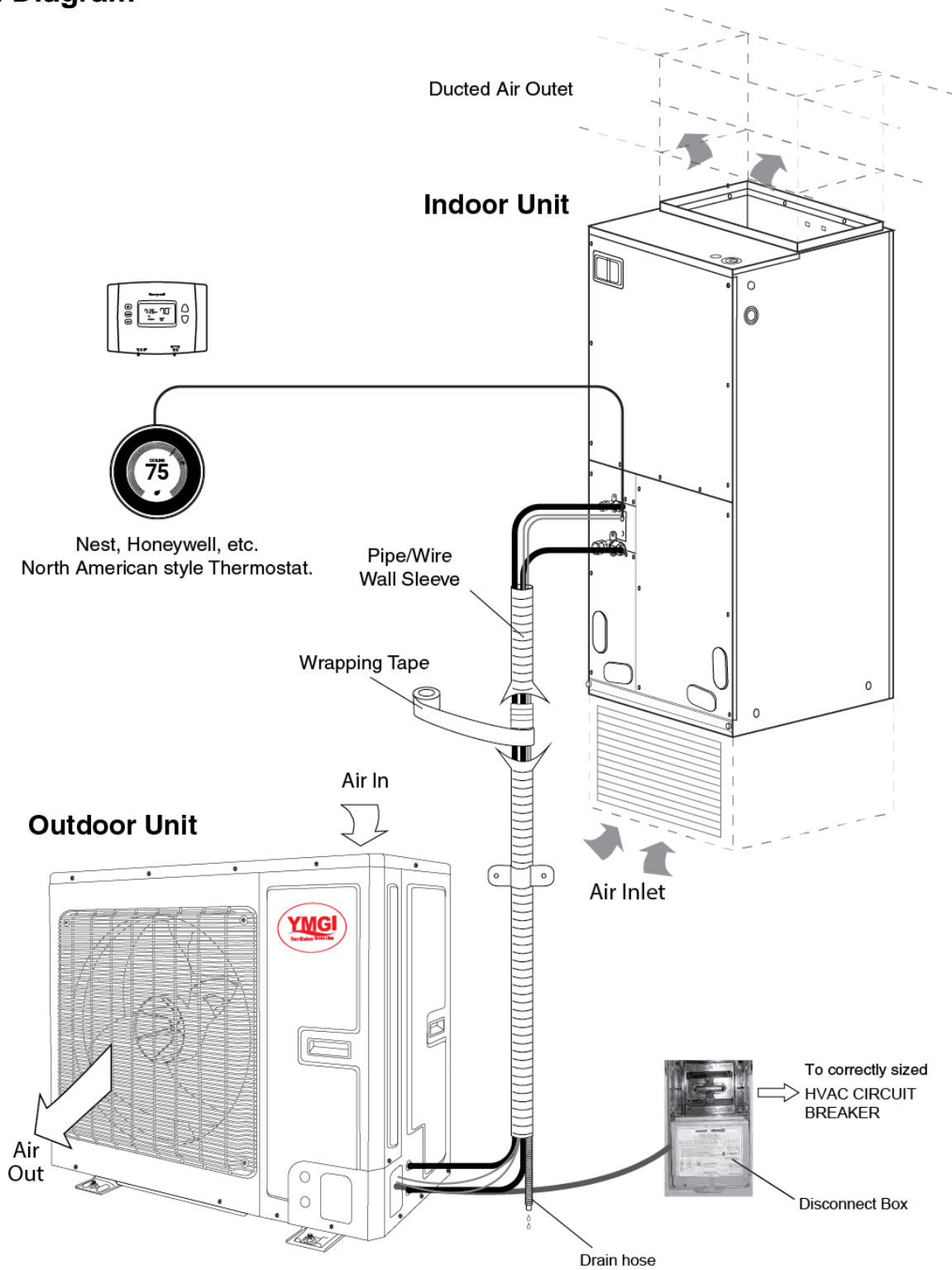

Notes: Actual unit/ part appearance and installation may vary from illustration.
Subject to continuous improvement and change without notice.

Product Introduction

⚠WARNING

Electrical shock hazard:



Failure to follow this warning could result in personal injury or death.

Before installing, modifying, or servicing system, main electrical disconnect switch must be in the OFF position. There may be more than 1 disconnect switch. Lock out and tag switch with a suitable warning label.

Product Description

The YMGI air handler offer the perfect combination of superior product quality, operating efficiency, operating sound levels and value for money. The condensing unit uses the environmentally friendly refrigerant R410A, which is chlorine-free to help prevent damage to the ozone layer.

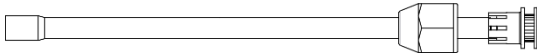
Optional Accessories

Outdoor Unit Accessories				
No.	Name	Appearance	Qty.	Usage
1	Throw-over pipe		1	Connect the unit with the liquid pipe
2	Throw-over pipe		1	Connect the unit with the gas pipe

Main Components

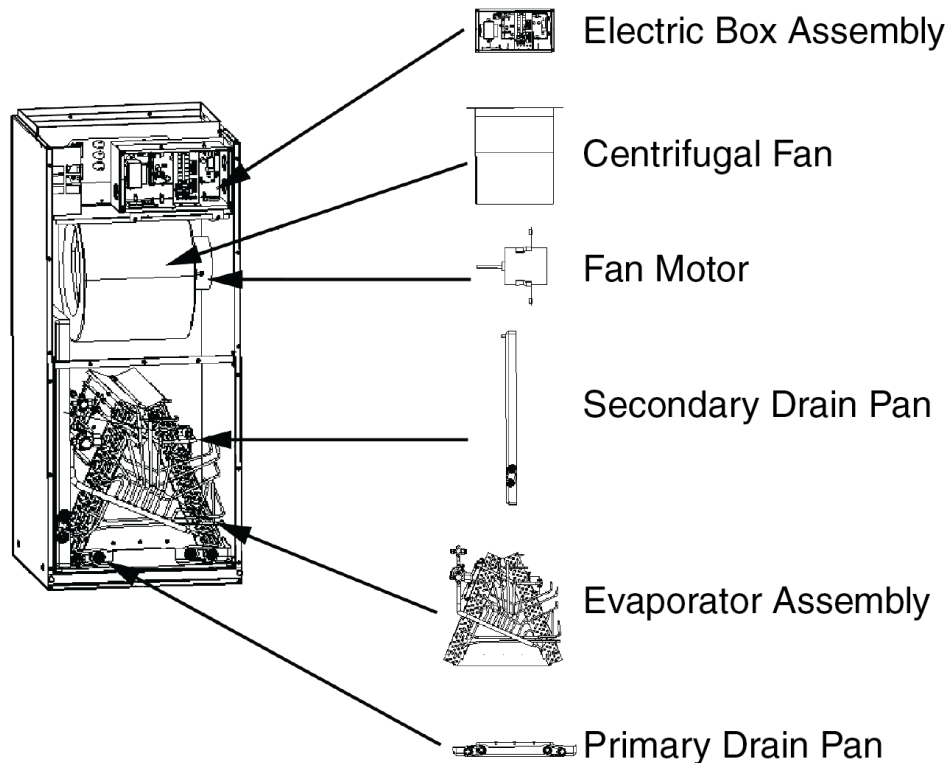

UNIT ENGINEERING SUBMITTALS-MECHANICAL INDOOR UNIT

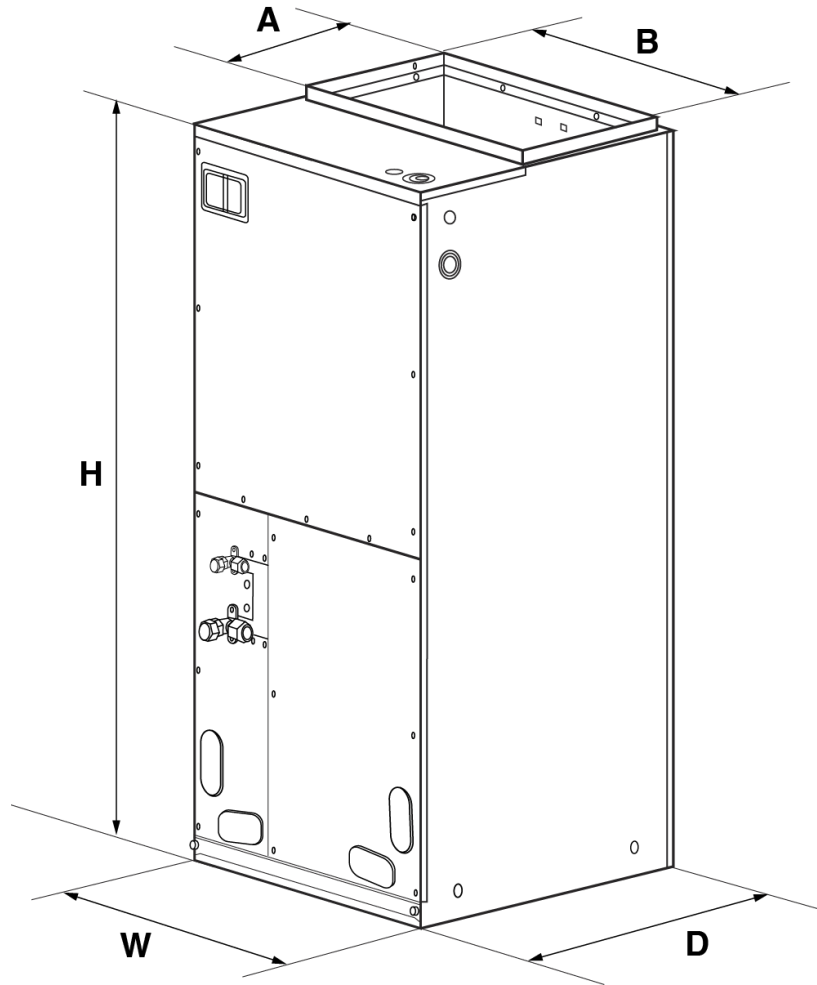

Model	Dimensions In. (mm)				
	W	D	H	A	B
VRUI-24UC-M2B(54)	21-1/4" (540)	21-1/4" (540)	48-1/4" (1224)	11-5/8" (295)	20" (508)
VRUI-36UC-M2B(54)	21-1/4" (540)	21-1/4" (540)	48-1/4" (1224)	11-5/8" (295)	20" (508)
VRUI-48UC-M2B(54)	24 51/64" (629.84)	21-1/4" (540)	57" (1448)	11-5/8" (295)	20" (508)
VRUI-60UC-M2B(54)	24 51/64" (629.84)	21-1/4" (540)	57" (1448)	11-5/8" (295)	20" (508)

(54) IDU Specification Sheet

Type			Air handler	Air handler	Air handler	Air handler	
Model			VRUI-24UC-M2B(54)	VRUI-36UC-M2B(54)	VRUI-48UC-M2B(54)	VRUI-60UC-M2B(54)	
Electrical Data	Power supply		V-Hz-Ph	208/230-60-1	208/230-60-1	208/230-60-1	208/230-60-1
	Power input ¹	Cooling	kW	0.14	0.18	0.42	0.42
		Heating	kW	0.14	0.18	0.42	0.42
	Input current ¹	Cooling	A	1.00	1.36	2.92	2.92
		Heating	A	1.00	1.36	2.92	2.92
	Max. Overcurrent Protection		A	15	15	15	15
	Min/Max Voltage	Min/Max Voltage (V)	V	187/253	187/253	187/253	187/253
Power cord spec	Electrical Conduit Size (Inch)	mm ² x pcs	/	/	/	/	
Fuse (A)		A	/	/	/	/	
Sound Pressure Level (SS/H/M/L)*		dB (A)	45	47	50	51	
Sound Power Level (SS/H/M/L)*		dB (A)	55	57	60	61	
Refrigerant	Type	—	R410A	R410A	R410A	R410A	
	Control	—	Thermal expansion valve	Thermal expansion valve	Thermal expansion valve	Thermal expansion valve	
Air Flow Volume(rated EXP)		CFM	940	1000.45	1470	1600	
		m ³ /h	1600	1700	2500	2720	
External Static Pressure		Rated	Pa	25	37	50	50
			InWg	0.1	0.148	0.2	0.2
		Range	Pa	0~100	0~100	0~100	0~100
			InWg	0~0.4	0~0.4	0~0.4	0~0.4
Fan Motor	Model		—	FGZ370B	FGZ370B	FGZ750B	FGZ750B
	Drive Type		—	Direct drive	Direct drive	Direct drive	Direct drive
	Speed		rpm	750	820	850	930
	Power Output		W	1/2	1/2	1	1
	Full Load Amp(FLA)		A	2.10	2.10	3.20	3.20
	Capacitor		uF	/	/	/	/
Fan	Type		—	Centrifugal	Centrifugal	Centrifugal	Centrifugal
	Quantity		—	1	1	1	1
	Diameter-Height		inch	φ10.24-9.69	φ10.24-9.69	φ10.87-11.26	φ10.87-11.26
Evaporator	Material		—	Inner groove copper tube- Aluminum fin	Inner groove copper tube- Aluminum fin	Inner groove copper tube- Aluminum fin	Inner groove copper tube- Aluminum fin
	Face Area		sq.ft	4.09	4.09	5.49	5.49
			m ²	0.38	0.38	0.51	0.51
	Pipe Diameter		in.	φ9/32"	φ9/32"	φ3/8"	φ3/8"
	Number of rows		—	4	4	4	4
	Tube pitch(a) x row pitch(b)		in.	3/4" x 1/2"	3/4" x 1/2"	1" x 55/64"	1" x 55/64"
Fins per Inch(FPI)		—	16	16	14	14	

	Fin type	—	Hydrophilic-window	Hydrophilic-window	Hydrophilic-window	Hydrophilic-window
	Number of circuits	—	12	12	12	12
	Length(L) x Height(H) x Width(W)	mm	415x50.8x457.2	415x50.8x457.2	415x88x609.6	415x88x609.6
Operation temp	Cooling	°F	64.4 ~ 80.6	64.4 ~ 80.6	64.4 ~ 80.6	64.4 ~ 80.6
	Heating	°F	68 ~ 80.6	68 ~ 80.6	68 ~ 80.6	68 ~ 80.6
Drainage Connection Size(Outer Diameter x Wall Thickness)		in.	Φ1" x 3/64"	Φ1" x 3/64"	Φ1" x 3/64"	Φ1" x 3/64"
System Operation Control		—	Wired controller	Wired controller	Wired controller	Wired controller
Dimension	Outline dimension (WxDxH)	in.	21 1/4" x 21 1/4" x 48 3/16"	21 1/4" x 21 1/4" x 48 3/16"	24 13/16" x 21 1/4" x 57"	24 13/16" x 21 1/4" x 57"
	Package dimension (LxWxH)	in.	26" x 23 47/64" x 50 25/64"	26" x 23 47/64" x 50 25/64"	27 9/32" x 26" x 59 3/8"	27 9/32" x 26" x 59 3/8"
Weight	Net Weight	kg	156.53	156.53	202.83	202.83
	Gross Weight	kg	169.76	169.76	218.26	218.26
Panel	Outline dimension (WxDxH)	mm	/	/	/	/
	Package dimension (WxDxH)	mm	/	/	/	/
	Net Weight	kg	/	/	/	/
	Gross Weight	kg	/	/	/	/

Notes:

1. The cooling capacity stated above is measured under following conditions:
Indoor Condition: 27°C (81°F) DB/19°C (66.6°F) WB.
Outdoor Condition: 35°C (95.4°F) DB/24°C (75.6°F) WB.
2. Noise is tested in the semi-anechoic room, so it will be slightly higher in operation due to environmental change.
3. "1" is tested under standard conditions.
"2" is tested under rated conditions according to CE/Eurovent standard:
4. * Fan different speed

General Information

Model	Cooling capacity(ton)	Optional electric heater (kW)
VRUI-24UC-M2B(54)	2.0	8
VRUI-36UC-M2B(54)	3.0	8
VRUI-48UC-M2B(54)	4.0	10/15/20
VRUI-60UC-M2B(54)	5.0	10/15/20

Model	Motor @ 230V ~ 60Hz	
	HP	FLA
VRUI-24UC-M2B(54)	1/2	2.1
VRUI-36UC-M2B(54)	1/2	2.1
VRUI-48UC-M2B(54)	1	3.20
VRUI-60UC-M2B(54)	1	3.20

Model	Filter size (mm)
VRUI-24UC-M2B(54)	19 1/4" x 20 5/16" x 5/8" 490x516x15
VRUI-36UC-M2B(54)	19 1/4" x 20 5/16" x 5/8" 490x516x15
VRUI-48UC-M2B(54)	22 13/16" x 20 5/16" x 5/8" 490x516x15
VRUI-60UC-M2B(54)	22 13/16" x 20 5/16" x 5/8" 490x516x15

NOTES:

1. Based upon W/nominal tonnage, dry coil and filter should be installed.
2. Use 0.96 as approximate SCFM correction factor for wet coil.

Preparing for Installation

Pre-Installation Instructions

Checking Product Received

After receiving the product, please inspect for any damage caused by transportation. Shipping damage is the responsibility of the carrier. Verify the model number, specifications and accessories are correct prior to installation. The distributor or manufacturer will not accept claims from dealers for transportation damage or installation of improperly shipped units.

Before Installation

Carefully read all instructions for the installation prior to installing product. Make sure each step or procedure is understood and any special considerations are taken into account before beginning installation. Assemble all tools, hardware and supplies needed to complete the installation. Some items may need to be purchased locally. Make sure everything needed to install the product is on hand before starting.

Codes & Regulations

This product is designed and manufactured to comply with national codes. It is installer's responsibilities to install the product in accordance with such codes and/or any prevailing local codes/regulations. The manufacturer assumes no responsibilities for equipment installed in violation of any codes or regulations.

Replacement Parts

When reporting shortages or damages, or ordering repair parts, give the complete product model and serial numbers as stamped on the product. Replacement parts for this product are available through your contractor or local distributor.

Important Safety Instructions

Recognize safety symbols, words, and labels

The following symbols and labels are used throughout this manual to indicate immediate or potential hazards. It is the owner's responsibility to read and comply with all safety information and instructions accompanying these symbols. Failure to heed safety information increases the risk of serious personal injury or death, property damage and/or product damage.

⚠ WARNING

Immediate hazards which will result in property damage, product damage, severe personal injury or death.

⚠ CAUTION

Hazards or unsafe practices could result in property damage, product damage, severe personal injury or death.

NOTICE

Hazards or unsafe practices which may result in property damage, product damage, severe personal injury or death.

⚠ WARNING

Before serving or installing this equipment. The electrical power to this unit must be in the "off" position. More than one disconnect may exist. Failure to observe this warning may result in an electrical shock that can cause personal injury or death.

⚠ WARNING

The United States Environmental Protection Agency ("EPA") has issued various regulations regarding the introduction and disposal of refrigerants introduced into this unit. Failure to follow these regulations may harm the environment and can lead to the imposition of substantial fines. These regulations may vary due to the passage of laws. A certified technician must perform the installation and service of this product. Should questions arise, contact your local EPA office.

⚠ WARNING

Due to high system pressure and electrical shock in potential, installation and service work can be dangerous. Only trained and qualified persons are permitted to install or service this equipment. Observe all warnings contained in this manual and labels/tags attached to the equipment.

⚠ WARNING

This product is factory shipped for use with a 208/230V-1Ph-60Hz electrical power supply. This air handler must not be reconfigured to operate with any other power supply.

⚠ WARNING

The unit must have an uninterrupted, unbroken electric grounding to minimize the possibility of personal injury if an electric fault occurs. The electric grounding circuit may consist of an appropriate sized power cord which connected with the grounding piece located in the unit control box and also connecting to the building electric service panel. Other methods of grounding are permitted if performed in accordance with the "National Electric Code" (NEC)/ "American National Standards Institute" (ANSI)/ "National Fire Protection Association" (NFPA) 70 and local/state codes. In Canada, electric grounding conforms to the Canadian electric code CSA c22.1. Failure to observe this warning can result in electrical shock that can cause personal injury.



CARBON MONOXIDE POISONING HAZARD

Special warning for installation of furnaces or air handling units in enclosed areas, such as garages, utility rooms or parking areas.

Carbon monoxide producing devices (such as an automobile, space heater, gas water heater, etc.) should not be operated in enclosed areas such as unventilated garages, utility rooms or parking areas because of the danger of carbon monoxide (CO) poisoning resulting from the exhaust emissions. If a furnace or air handler is installed in an enclosed area such as a garage, utility room or parking area and a carbon monoxide producing device is operated therein, there must be adequate ventilation directly to outside.

This ventilation is necessary to avoid the danger of CO poisoning which can occur if a carbon monoxide producing device continues to operate in the enclosed area. Carbon monoxide emission can be (re)circulated throughout the building if the furnace or air handler is operating in any mode.

CO can cause serious illness including permanent brain damage or death.

RECOMMENDED TOOLS FOR INSTALLATION

1. Mounting Indoor & Outdoor Units and Running Piping/Wiring

- Ruler
- Stud-Finder
- Dry-Wall Saw
- Electric Drill
- 3" Hole Saw
- Drill Extension
- Hammer Drill and Bit
- Measuring Tape
- Level
- Flash Light
- Screw Driver (Phillips and Flat)
- Hammer
- Knife
- Scissors
- Goggled Glasses
- Mask
- Gloves
- Ladder



2. Refrigeration Related Work

- Flat Surface Wrench (Two)
- Flare-Nut Tool Set
- Hex Head Key Set
- Torch for AC Application
- Heat Absorption Flux
- Nitrogen
- Soap Bubble
- Vacuum Pump
- Helium Leakage Check
- Manifold



3. Electrical Related Installation

- Wire Cutter
- Wire Stripper
- Sharp Plier
- Cable Ties
- Black Tape for Electrical Use
- Electrical Meter

4. Trial Running Units and Inspection

- Clamp Meter
- Manifold
- Infrared Thermometer

Installation

Unit Inspection

Upon delivery, inspect the unit for damage. Any damage must be reported immediately to the carrier. Do not install such an equipment damaged by freight which determines the integrity and safety of the unit.

Please check the equipment model number to ensure the unit is appropriately sized for the condensing unit.

If an incorrect unit is supplied, it must not be installed and it is to be returned to the supplier. The manufacturer assumes no responsibility for the installation of incorrectly delivered units. The evaporator coil contains high-pressure inert gas for holding charge.

Location

⚠WARNING

This air handler is designed for indoor installation only. Do not install it outdoors.

When installing the air handler, take consideration to minimize the length of refrigerant tubing as much as possible. Do not install the air handler in a location either above or below the condenser that violates the instructions provided with the condenser. Service clearance is to take precedence. Allow a minimum of 24" in front of the unit for service clearance. When installing in an area directly over a finished ceiling (such as an attic), an emergency drain pan is required directly under the unit. See local and state codes for requirements. When installing this unit in an area that may become wet, elevate the unit with a sturdy, non-porous material. In installations that may lead to physical damage (i.e. a garage) it is advised to install a protective barrier to prevent such damage.

This air handler is designed for a complete supply and return ductwork system. Do not operate this product without all ductwork attached.

Based upon the actual conditions, if air handler is installed as Fig. A, the air handler should be concealed in a specific room or space and make sure the air handler is not accessible to the general public.

Based upon the actual conditions, if air handler is installed as Fig. B, make sure that there is enough space for care and maintenance and the height between the air handler and ground is above 2500mm. And the air handler is not accessible to the general public.

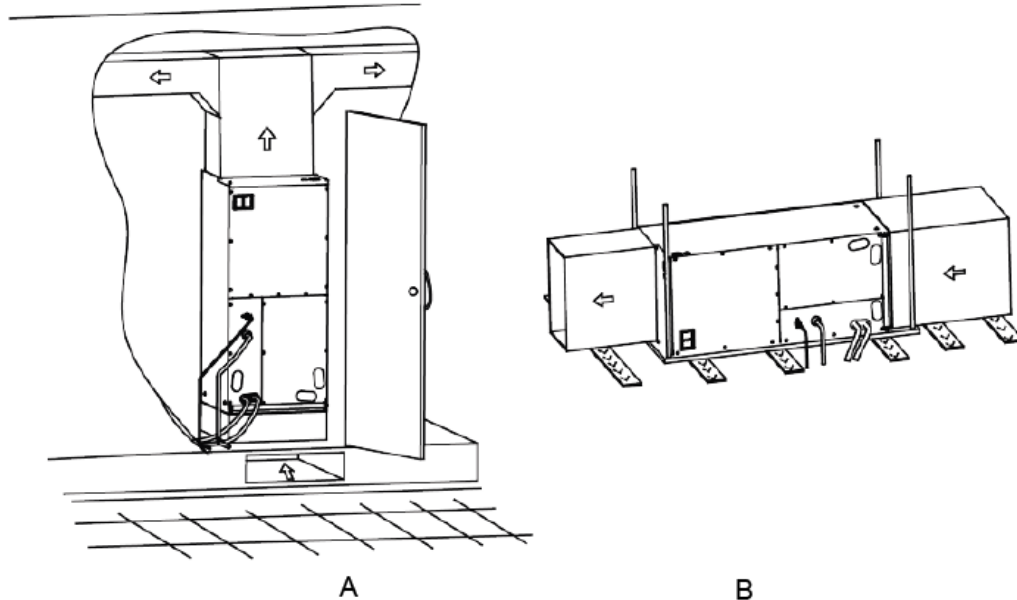

Piping Work Specification of Connection Pipe

Model	External diameter (inch)	
	Gas pipe	Liquid pipe
VRUI-24UC-M2B(54)	Φ3/4	Φ3/8
VRUI-36UC-M2B(54)	Φ3/4	Φ3/8
VRUI-48UC-M2B(54)	Φ3/4	Φ3/8
VRUI-60UC-M2B(54)	Φ3/4	Φ3/8

Piping Preparation Solder Connection

All cut ends are to be round, burr free, and cleaned. Failure to follow this practice increases the chances for refrigerant leakage.

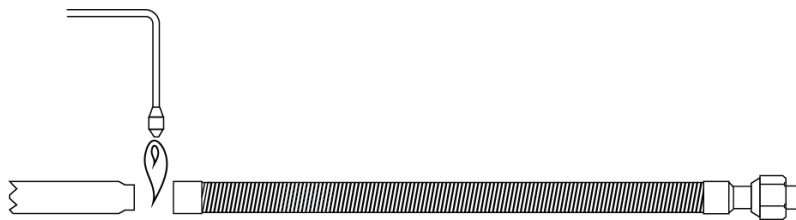
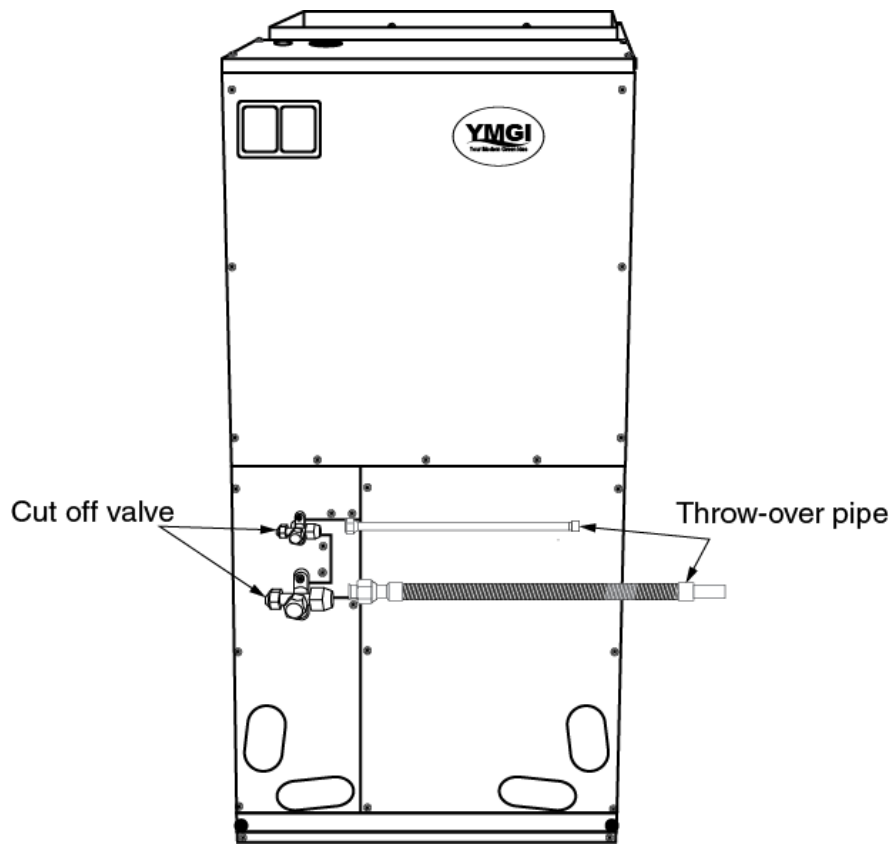

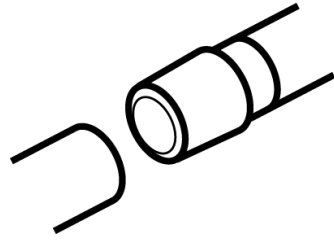

LINE SET SIZE MATCHES SERVICE VALVE CONNECTION

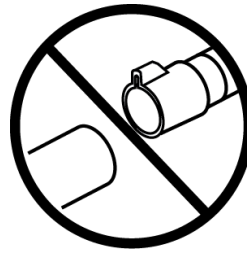

DO NOT CRIMP SERVICE VALVE CONNECT OR WHEN PIPE IS SMALLER THAN CONNECTION

Screw Connection

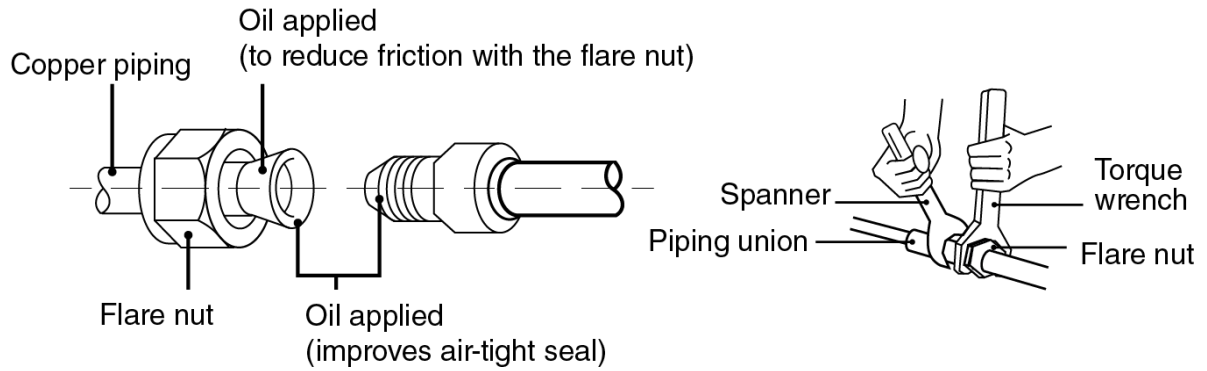

Screw Connection	Tightening torque (N-m)
Φ1/4	15-30
Φ3/8	35-40
Φ1/2	45-50
Φ5/8	60-65
Φ3/4	70-75
Φ7/8	80-85

Condensate Removal

1. It is not allowed to connect the condensate drain pipe into waste pipe or other pipelines which are likely to produce corrosive or peculiar smell to prevent the smell from entering indoors or corrupt the unit.
2. It is not allowed to connect the condensate drain pipe into rain pipe to prevent rain water from pouring in and cause property loss or personal injury.
3. Condensate drain pipe should be connected into special drain system for air conditioner.
4. The drain pan has primary and secondary drain connection. Condensate removal is performed by attaching a 3/4" PVC pipe to the evaporator coil pan and terminated in accordance with local or state Plumbing/HVAC codes. The installation must include a "P" style trap that is located closely to the evaporator coil. Do not over-tighten the drain connection in order to prevent possible damage to the evaporator drain pan. See the following figure for details of a typical condensate line "P" trap.

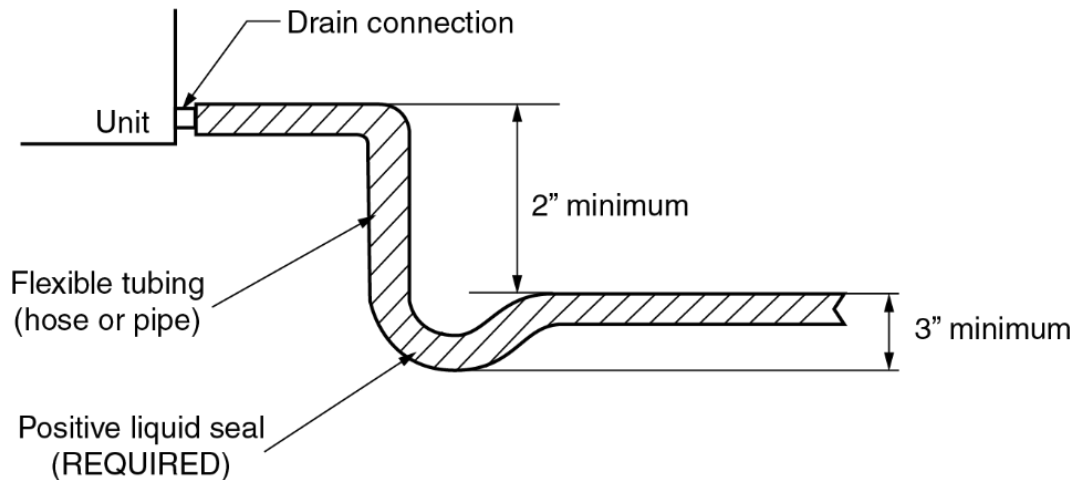

NOTICE

1. It is not allowed to connect the condensate drain pipe into waste pipe or other pipelines which are likely to produce corrosive or peculiar smell to prevent the smell from entering indoors or corrupt the unit.
2. It is not allowed to connect the condensate drain pipe into rain pipe to prevent rain water from pouring in and cause property loss or personal injury.
3. Condensate drain pipe should be connected into special drain system for air conditioner.

Ductwork

This air handler is designed for a complete supply and return ductwork system.

⚠WARNING

- Do not operate the unit without all ductwork completed.
- Do not operate this product without all ductwork attached.
- Inadequate ductwork that restricts airflow can result in improper performance and compressor or heater failure. Ductwork is to be constructed in a manner that limits restrictions and maintains suitable air velocity. Ductwork is to be sealed to the unit in a manner that will prevent leakage.
- Return ductwork: Do not terminate the return ductwork in an area that can introduce toxic, or objectionable fumes/odors into the ductwork. The return ductwork is to be introduced into the air handler bottom (up flow configuration).
- Return Air Filters: Each installation must include a return air filter. This filtering may be performed at the air handler or externally such as a return air filter grille.

Electric Heater

The air handlers listed in this manual do not have factory installed electric heat. Electric heat is available as an accessory. The only heater kits that can be used are HNRd series. Please refer to installation instructions provided with heater kit for the correct installation procedure.

⚠WARNING

Refer to the “installing electric heater” section of this manual and the instructions provided with the heater kit for the correct installation procedure.

⚠WARNING

The electrical characteristics of the air handler, the electric heater kit, and the supply power should be identical. This air handler does not have factory installed electric heater. Electric heater is available as an accessory. If installing this option, the only heater kits that can be used are the HNRd series as indicated below.

HNRd Electric Heater Kits Available

SN.	Model	Description	Ref. air handler use(ton)	Applications	Circuit Breaker Size
1	21-4216-00	Circuit breaker, 8kW heat strip	2.0/3.0	Residential and Commercial	50A 1 Phase
2	21-4216-01	Circuit breaker, 10kW heat strip	4.0/5.0		60A 1 Phase
3	21-4217-00	Circuit breaker, 15kW heat strip	4.0/5.0	Commercial Only	100A 1 Phase / 60 A 3 Phase
4	21-4218-00	Circuit breaker, 20kW heat strip	4.0/5.0		120A 1 Phase / 80A 3 Phase

HNRd Heater Kits Installation

1. Ensure that all power supply is disconnected prior to installing the heater kit.
2. A means of strain relief and conductor protection must be provided at the supply wire entrance into cabinet.
3. Use copper conductors only.
4. Installation must follow national electric code and other applicable codes.
5. If this appliance is installed in an enclosed area such as a garage or utility room with any carbon monoxide producing appliance, ensure the area is properly ventilated.
 - 1) Refer to the Table for appropriate HNRd heater kit.
 - 2) Check any physical damage, do not install damaged heater kit.
 - 3) Remove the upper access panel from air handler.
 - 4) Remove cover plate from air handler.
 - 5) The heater kit in to the slot and secure element plate with previously removed screws.
 - 6) Insert power leads into the circuit breaker lugs or stripped red and black wires (for heater kit without circuit breaker) and tighten.
 - 7) Connect ground wire to ground lug.
 - 8) Break out appropriate area of the plastic circuit breaker cover on the access panel of the air handler.
 - 9) Replace access panel and check operation.

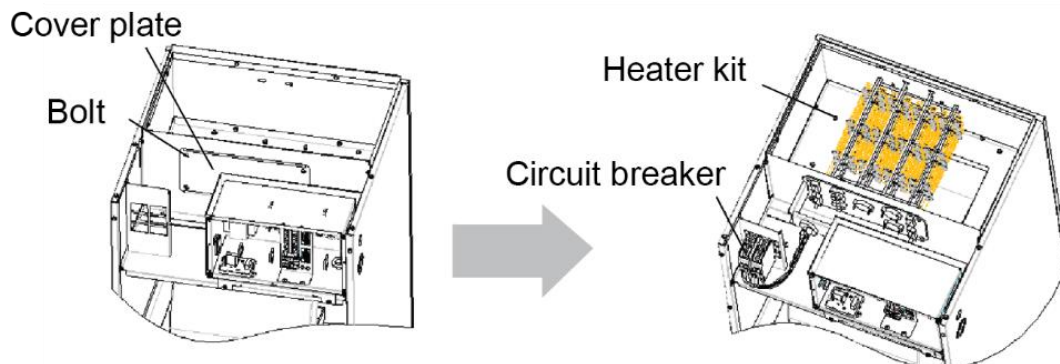

10) Connection of power cords and temperature controller cords.

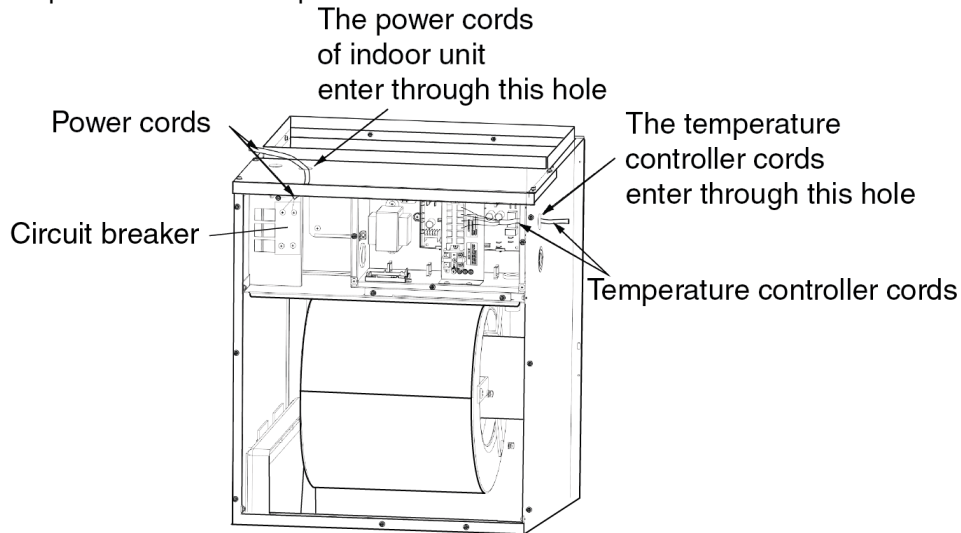

YMG Recommendations for Safe Installation:

1. Indoor Unit needs to be connected to a dedicated 15 or 20A Circuit Breaker (double-pole) that is located in the power supply panel.
2. Optional Electrical Heater, if installed, must be connected to another circuit breaker at the power supply panel that is properly sized and separated from the circuit breaker for the indoor unit. **DO NOT** mix-use/share the circuit breaker between indoor unit and optional electrical heater.

For both indoor unit and optional electrical heater:

Use only armored or conduit-protected good copper wire with at least 90C grade of insulation. Add a toggle-switch by the indoor unit and/electrical heater, as needed or required. Fasten every wire connection securely and check for adequate clearances from sharp, hot, or moving objects, and avoid moisture.

Only qualified technicians/electricians are allowed to perform the installation. Follow manufacturer’s installation instructions/recommendations, as well as NEC and local codes all the time. Failure to do so can cause electrical damage to the unit, electrical heater, injury to body and even fire.

Electrical Installation

Requirement and Notice on Electrical Installation

The electrical installation for the air conditioner should observe the following requirements:

1. The electrical installation must be conducted by professionals in compliance with local laws and regulations and the instructions in this manual. Never extend the power cord. The electric circuit must be equipped with a circuit breaker and air switch both with sufficient capacity.
2. The unit’s operating power must be within the nominal range stated in the instruction manual. Use a specialized power circuit for the air conditioner. Do not draw power from another power circuit.
3. The air conditioner circuit should be at least 1.5m (5 feet) away from any inflammable surface.
4. The external power cord, connection wire of indoor unit and temperature controller and the communication cords must be effectively fixed.
5. The external power cord, connection wire of indoor unit and temperature controller and the communication cords can’t directly contact any hot objects. For example: they must not contact chimney pipes, warm gas pipes or other hot objects.
6. The external power cord, communication cords, and the connection wire of indoor unit and temperature controller must not be squeezed. Never pull, stretch or bend the wires.
7. The external power cord, communication cords and the connection wire of indoor unit and temperature controller must not collide with any metal beam or edge on the ceiling, or touch any metal burrs or sharp metal edge around.
8. Connect wires correspondingly by referring to the circuit diagram labeled on the unit or electric box. Screws must be tightened up. Slipped screws must be replaced by specialized flat-head screws.

9. Please use the power cables that are delivered along with the air conditioner. Do not change the power cables arbitrarily. Do not change the length and terminals of the power cables. If you want to change the power cables, please contact YMGI's local service center.
10. Wiring terminals should be connected firmly to the terminal board. Loose connection is forbidden.
11. After the electrical installation is finished, please use wire clamps to secure the power cord, connection wire of indoor unit and temperature controller and the communication cords. Make sure the wires are not clamped too tight.
12. The wire gauge of power cord should be large enough. Damaged power cord or other wires must be replaced by specialized wires. Wiring work must be done according to national wiring rules and regulations.

Electrical Parameters

Model	Power supply	Minimum circuit ampacity (A)	Maximum overcurrent protection (A)
VRUI-24UC-M2B(54)	208/230V-1Ph-60Hz	4	15
VRUI-36UC-M2B(54)	208/230V-1Ph-60Hz	4	15
VRUI-48UC-M2B(54)	208/230V-1Ph-60Hz	4	15
VRUI-60UC-M2B(54)	208/230V-1Ph-60Hz	4	15

NOTICE

1. Fuse is located on the main board.
2. Install a circuit breaker at every power terminal near the units (indoor unit and temperature controller) with at least 1/8 in. (3mm) contact gap. The units must be able to be plugged or unplugged.
3. Circuit breaker and power cord specifications listed in the above table are determined based on the maximum power input of the units.
4. Specifications of power cords listed in the above table are applicable in working condition where ambient temperature is 104°F (40°C) and multi-core copper cable (e.g. YJV copper cable, with insulated PE and PVC sheath) is protected by a conduit, and is resistant to 194°F (90°C) in maximum (see IEC 60364-5-52). If working condition changes, please adjust the specifications according to national standards.
5. Specifications of circuit breaker are based on a working condition where the working temperature is 104°F (40°C). If working condition changes, please adjust the specifications according to national standards.
6. Adopt 5pc of AWG18 power cords to be the communication cords between indoor unit and temperature controller. The maximum length is 98.5 ft. (30m). Please select a proper length according to local conditions. Communication cords must not be twisted together.
7. The wire gauge of communication cord should not be less than AWG18. It's recommended to use AWG18 power cords as the communication cords.

Connection of Power Wires and Communication Wires

1. For solid wires (as shown below):
 - 1) Use wire cutters to cut off the wire end and then peel away about 25mm of the insulation layer.
 - 2) Use a screwdriver to unscrew the terminal screw on the terminal board.
 - 3) Use nippers to bend the solid wire into a ring that fits the terminal screw.
 - 4) Form a proper ring and then put it on the terminal board. Use a screwdriver to tighten up the terminal screw.
2. For strand wires (as shown below):
 - 1) Use wire cutters to cut off the wire end and then peel away about 10mm of the insulation layer.
 - 2) Use a screwdriver to unscrew the terminal screw on the terminal board.
 - 3) Use a round terminal fastener or clamp to fix the round terminal firmly on the peeled wire end.
 - 4) Locate the round terminal conduit. Use a screwdriver to replace it and tighten the terminal screw (as shown below).

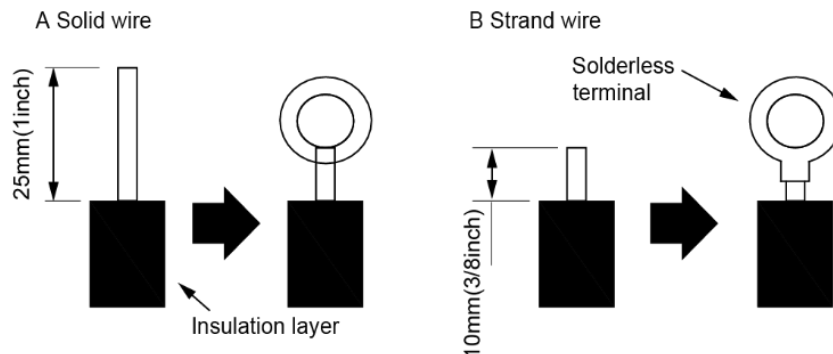

- How to connect the connection wire and power cord.
Lead the connection wire and power cord through the insulation tube. Then fix the wires with wire clamps (as shown in the following figure.)

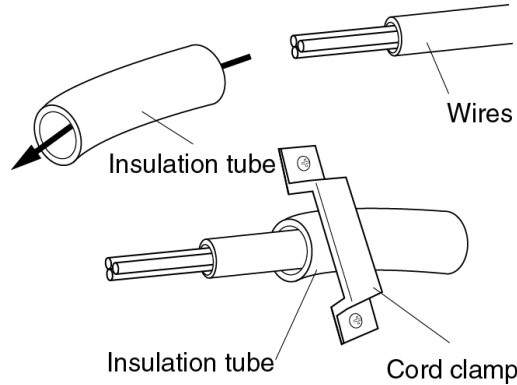

⚠WARNING

- Before working, please check whether the indoor unit and temperature controller are powered on.
- Match the terminal numbers and wire colors with the colors indicated in the indoor unit.
- Wrong wire connection may burn the electrical components.
- Connect the wires firmly to the wiring box. Incomplete installation may lead to fire hazard.
- Please use wire clamps to secure the external covers of connecting wires. (Insulators must be clamped securely; otherwise, electric leakage may occur.)
- Ground wire should be connected.

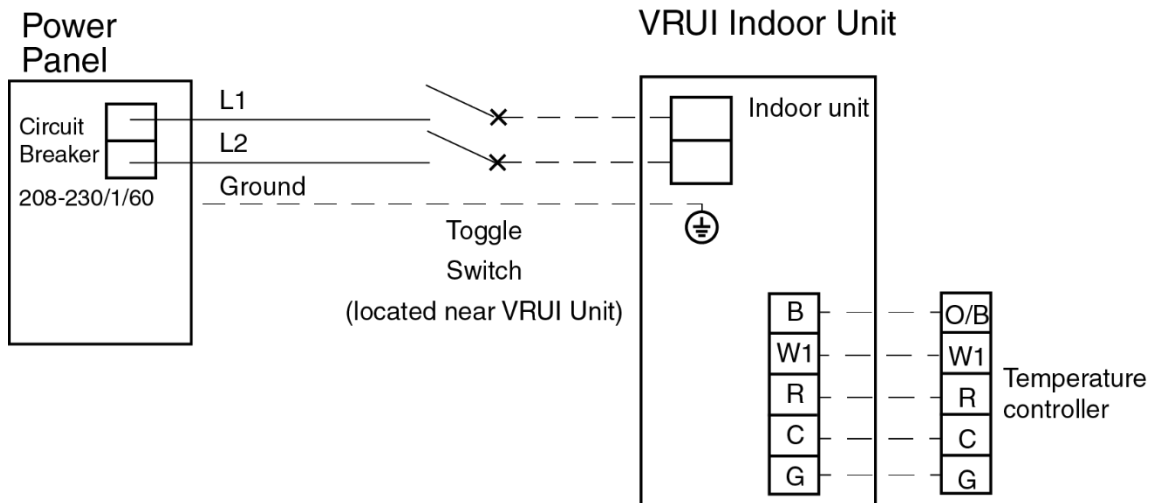

⚠WARNING

- High and low voltage wires should be led through different rubber rings of the electric box cover.
- Do not bundle up the connection wire and communication wire of wired control or lay them side by side, otherwise errors will occur.
- High and low voltage wires should be secured separately. Secure the former ones with big clamps and the latter ones with small clamps.
- Use screws to tighten up the connection wires and power cords of unit on the terminal board. Wrong connection may lead to fire hazard.
- If the connection wires of unit and power cords are not correctly connected, the air conditioner may get damaged.
- Ground the unit through connecting the ground wire.
- The units should comply with applicable local and national rules and regulations on power consumption.
- When connecting the power cord, make sure the phase sequence of the power supply matches with the corresponding terminals, otherwise the compressor will get reversed and operate abnormally.

Installation Checklist for Trial Run

Checking Items after Installation

Items to be checked	Problems might happen due to improper installation	Check
Check if each parts of the unit have been installed reliably.	The unit might fall off, vibrate or emit noise.	
Check if the unit has passed through leakage test.	It may cause deficiency of cooling (heating) capacity.	
Check if the unit has been insulated properly.	It may cause condensation and water drip.	
Check if the water can be drained fluently.	It may cause condensation and water drip.	
Check if the power voltage coincides with that on the nameplate.	Malfunction might happen and parts might be burned.	
Check if the wiring and pipe line has been installed correctly.	Malfunction might happen and parts might be burned.	
Check if the unit has been grounded securely.	Hazard of electricity leakage.	
Check if the wiring uses the correct gauge wire.	Malfunction might happen and parts might be burned.	
Check if there is obstruction blocking the air inlet/outlet.	It may cause deficiency of cooling (heating) capacity.	
Check if the piping length and refrigeration charging volume has been recorded.	Uncertain about the refrigerant charging volume.	
Check if the piping connection and valves have been set properly.	It may cause unit abnormality and/or damage the unit.	
Make sure there is no crack among air return and supply pipe.	It may cause air leak, vibration and noise.	
Check if the panel is mounted firmly.	It may cause air leak, vibration and condensation.	

Trial Run

Preparative for Trial Run

1. Never power on the unit until all the installation work has been done.
2. All the control circuit and wiring has been connected correctly and soundly. Valves on the gas and liquid line should be completely open.
3. All the scattered objects should be removed, especially metal filing, thrum and clip.
4. Check if the unit appearance and piping system has been damaged during transportation or handling.
5. Check if the terminals are loose and the phases are correct.

Trial Run

1. Trial run can be operated by professional personnel only after above items have been checked (items to be checked as per actual condition).
2. Power on the unit and press ON/OFF button to activate.
3. After compressor starting up, please immediately stop the unit when abnormal sound emits.
4. Trial run under several modes and check if the unit operates normally.

Troubleshooting

If the unit doesn't run normally, please check the following items before ask for

Phenomenon	Reason	Remedy
The unit cannot be activated.	The unit doesn't connect with power supply.	Connect with power supply.
	Low voltage.	Check if circuit voltage is within rated scope.
	Fuse broken or breaker trips off.	Replace fuse or connect breaker.
The unit operates but stops immediately.	Air inlet/outlet of indoor unit is blocked.	Remove obstacles.
Abnormal cooling or heating.	Air inlet/outlet of indoor unit is blocked.	Remove obstacles.
	Inappropriate temperature setting.	Adjust setting at wired controller.
	Doors or windows are opened.	Close the door or windows.
	Direct sunshine.	Draw curtain or louver.
	Too much heat source in the room.	Reduce heat source.
	Filter screen is blocked by dirt.	Clean the filter.

NOTE:

If reasons are still unclear after checking above items, please contact YMGI service center and show phenomena and models.

Following circumstances are not malfunctions.

Malfunction		Reason
Unit doesn't run.	When unit is started immediately after it is just turned off.	Overload protection switch makes it run after 3 minutes delay.
	When power is turned on.	Standby operating for about 1 minute.
Mist comes from the unit.	Under cooling.	Indoor high humidity air is cooled rapidly.
The unit emits noise.	Slight cracking sound is heard when just turned on.	It is noise when electronic expansion valve initialization.
	There is consecutive sound when cooling.	That's sound for gas refrigerant flowing in the unit.
	There is sound when unit starts or stops.	That's sound for gas refrigerant stops flowing.
	There is slight and consecutive sound when unit is running or after running.	That's sound for operation of drainage system.
The unit blows out dust.	When unit runs after no operation for a long period.	Dust in indoor unit is blew out.
The unit emits odor.	Operating.	The room odor absorbed by the unit is blew out again.
Indoor unit still runs after switch off.	After every indoor unit receive "stop" signal, fan will keep running.	Indoor fan can be set as "ON" or "AUTO" mode. Under "ON" mode, indoor fan will keep running after switch off the unit.

Maintenance and Care

Regular check, maintenance and care should be performed by professional personnel, which will prolong the unit life span.

Drain Pipe

Regularly check if the drain pipe is clogged in order to drain condensate smoothly.

Notice before Seasonal Use

1. Check if the inlet/outlet of the indoor unit is clogged.
2. Check if the ground wire is earthed reliably.
3. Check if the filter screen has been set soundly.
4. Check if the unit is installed firmly. If there is something abnormal, please contact the local appointed service center.

Maintenance after Seasonal Use

1. Cut off main power supply of the unit.
2. Clean filter screen of indoor units.
3. Clean the dust of sundries on the indoor units.
4. In the event of rusting, use the anti-rust paint to stop spreading of rust.

Parts Replacement

Purchase parts from YMGI if necessary.

After-Sales Service

In case the air-conditioning unit you bought has any quality problem or you have any inquiry, please contact your installing HVAC technician. If the service technician needs assistance trouble shooting the system, have them contact YMGI from the installation site at 866-833-3138.

Warranty should meet the following requirements:

1. First run of the unit should be operated by professional HVAC technician.
2. Only factory manufactured accessories can be used on the machine.
3. All the instructions listed in this manual should be followed.
4. Warranty will be automatically invalid if fails to obey any item mentioned above.



Heating and Cooling Performance

VRUI-24UC-M2B(54)

	Outdoor Temperature		Indoor Temperature											
			60°F (15°C)				70°F (21°C)				80°F (27°C)			
	°C	°F	Capacity	Power Input	COP	Capacity	Power Input	COP	Capacity	Power Input	COP			
Heating	-30°C	-22°F	18900	3800	4.97	18700	3920	4.77	18300	3960	4.62			
	-26°C	-15°F	22200	3900	5.69	22000	4000	5.50	21500	4040	5.32			
	-21°C	-5°F	24200	4000	6.05	24000	4200	5.71	23500	4240	5.54			
	-15°C	5°F	24200	3000	8.07	24000	3350	7.16	23500	3380	6.95			
	-8°C	17°F	25000	2700	9.26	24000	2900	8.28	23500	3460	6.79			
	0°C	32°F	25000	2285	10.94	24000	2300	10.43	23500	2530	9.29			
	8°C	47°F	27000	1930	13.99	26000	1980	13.13	24500	2100	11.67			
	15°C	60°F	29000	2000	14.50	28000	2100	13.33	26000	2200	11.82			
	20°C	68°F	28000	1900	14.74	28000	2000	14.00	24000	1900	12.63			
	24°C	75°F	24000	1600	15.00	24000	1700	14.12	24000	1850	12.97			
	Cooling	Outdoor Temperature		Indoor Temperature										
		60°F (15°C)				70°F(21°C)				80°F(27°C)				
°C		°F	Capacity	Power Input	EER	SHC	Capacity	Power Input	EER	SHC	Capacity	Power Input	EER	SHC
-15°C		5°F	17600	1000	17.60	13816	20400	1070	19.07	16014	24000	1160	20.69	18840
-10°C		14°F	17600	1020	17.25	14080	20400	1120	18.21	16320	24000	1185	20.25	19200
0°C		32°F	17600	1170	15.04	14044.8	20400	1180	17.29	16279.2	24000	1220	19.67	19152
5°C		41°F	17600	1210	14.55	13992	20400	1270	16.06	16218	24000	1280	18.75	19080
10°C		50°F	17600	1250	14.08	13816	20400	1320	15.45	16014	24000	1370	17.52	18840
18°C		65°F	17600	1300	13.54	14080	20400	1400	14.57	16320	24000	1450	16.55	19200
24°C		75°F	17600	1350	13.04	14044.8	20400	1520	13.42	16279.2	24000	1530	15.69	19152
30°C		85°F	17600	1520	11.58	13992	20400	1710	11.93	16218	25000	1870	13.37	19875
35°C		95°F	17600	1900	9.26	14080	20400	1850	11.03	16320	25000	2150	11.63	20000
41°C		105°F	17600	2280	7.72	13904	20400	2250	9.07	16116	24000	2340	10.26	18960
46°C	115°F	17600	2500	7.04	14256	20400	2600	7.85	16524	24000	2700	8.89	19440	
54°C	129°F	17500	2900	6.03	12425	19000	2900	6.55	13490	22000	2900	7.59	15620	





VRUI-36UC-M2B(54)

	Outdoor Temperature		Indoor Temperature											
			60°F (15°C)				70°F(21°C)				80°F(27°C)			
	°C	°F	Capacity	Power Input	COP	Capacity	Power Input	COP	Capacity	Power Input	COP			
Heating	-30°C	-22°F	18600	4060	4.58	18400	4150	4.43	18000	4190	4.30			
	-26°C	-15°F	21300	4340	4.91	21100	4430	4.76	20600	4470	4.61			
	-21°C	-5°F	25500	4530	5.63	25200	4630	5.44	24800	4670	5.31			
	-15°C	5°F	31000	4200	7.38	30000	4800	6.25	26000	4200	6.19			
	-8°C	17°F	37000	4800	7.71	36000	5450	6.61	31000	4800	6.46			
	0°C	32°F	37000	4200	8.81	36000	4800	7.50	33000	4850	6.80			
	8°C	47°F	38500	3150	12.22	38000	3600	10.56	33000	3100	10.65			
	15°C	60°F	38500	2900	13.28	38000	3150	12.06	30000	2700	11.11			
	20°C	68°F	36000	2850	12.63	38000	3120	12.18	30000	2400	12.50			
	24°C	75°F	30000	2450	12.24	36000	2950	12.20	30000	2350	12.77			
Cooling	Outdoor Temperature		Indoor Temperature											
			60°F (15°C)				70°F(21°C)				80°F(27°C)			
	°C	°F	Capacity	Power Input	EER	SHC	Capacity	Power Input	EER	SHC	Capacity	Power Input	EER	SHC
	-15°C	5°F	23400	1910	12.25	16029	30600	2050	14.93	20961	36000	2210	16.29	24660
	-10°C	14°F	23400	1980	11.82	16380	30600	2120	14.43	21420	36000	2260	15.93	25200
	0°C	32°F	23400	2030	11.53	16333	30600	2200	13.91	21359	36000	2320	15.52	25128
	5°C	41°F	23400	2100	11.14	16263	30600	2320	13.19	21267	36000	2410	14.94	25020
	10°C	50°F	23400	2200	10.64	16380	30600	2400	12.75	21420	36000	2500	14.40	25200
	18°C	65°F	23400	2280	10.26	16380	30600	2500	12.24	21420	36000	2600	13.85	25200
	24°C	75°F	23400	2350	9.96	16333	30600	2600	11.77	21359	36000	2700	13.33	25128
	30°C	85°F	23400	2400	9.75	16263	30600	2800	10.93	21267	37000	3100	11.94	25715
	35°C	95°F	23400	2610	8.97	16380	30600	3100	9.87	21420	37000	3600	10.28	25900
	41°C	105°F	23400	3680	6.36	16146	30600	4370	7.00	21114	36000	4400	8.18	24840
46°C	115°F	21450	3440	6.24	15230	28050	4080	6.88	19916	33000	4100	8.05	23430	
54°C	129°F	18000	3000	6.00	12780	20000	3000	6.67	14200	23000	3000	7.67	16330	





VRUI-48UC-M2B(54)

	Outdoor Temperature		Indoor Temperature											
			60°F (15°C)				70°F(21°C)				80°F(27°C)			
	°C	°F	Capacity	Power Input	COP		Capacity	Power Input	COP		Capacity	Power Input	COP	
Heating	-30°C	-22°F	26600	5580	4.77		26400	5700	4.63		25800	5750	4.49	
	-26°C	-15°F	30000	5780	5.19		28500	5900	4.83		27900	5960	4.68	
	-21°C	-5°F	34500	6070	5.68		34200	6200	5.52		33500	6260	5.35	
	-15°C	5°F	43900	6470	6.79		43000	6920	6.21		39700	6660	5.96	
	-8°C	17°F	48500	5980	8.11		48000	6880	6.98		44000	6480	6.79	
	0°C	32°F	48500	5680	8.54		48000	5800	8.28		47000	5860	8.02	
	8°C	47°F	48500	3850	12.60		50000	4210	11.88		47500	4320	11.00	
	15°C	60°F	52500	4560	11.51		52000	4650	11.18		49000	4250	11.53	
	20°C	68°F	52000	4450	11.69		52000	4500	11.56		48000	4150	11.57	
	24°C	75°F	48000	4020	11.94		48000	4100	11.71		46000	3900	11.79	
Cooling	Outdoor Temperature		Indoor Temperature											
			60°F (15°C)				70°F(21°C)				80°F(27°C)			
	°C	°F	Capacity	Power Input	EER	SHC	Capacity	Power Input	EER	SHC	Capacity	Power Input	EER	SHC
	-15°C	5°F	29640	2280	13.00	21637.2	40800	2620	15.57	29784	48000	3050	15.74	34320
	-10°C	14°F	29640	2350	12.61	21281.52	40800	2700	15.11	29294.4	48000	3100	15.48	35040
	0°C	32°F	29640	2410	12.30	21489	40800	2810	14.52	29580	48000	3190	15.05	34464
	5°C	41°F	29640	2490	11.90	21637.2	40800	2920	13.97	29784	48000	3280	14.63	34800
	10°C	50°F	29640	2580	11.49	21044.4	40800	3000	13.60	28968	48000	3400	14.12	35040
	18°C	65°F	29800	2650	11.25	21754	40800	3560	11.46	29784	48000	3750	12.80	35040
	24°C	75°F	31200	2980	10.47	22401.6	40800	3650	11.18	29294.4	48000	3850	12.47	34464
	30°C	85°F	31200	3140	9.94	22620	40800	3850	10.60	29580	48900	4100	11.93	35452.5
	35°C	95°F	31200	3480	8.97	22776	40800	4130	9.88	29784	48900	4720	10.36	35697
	41°C	105°F	29800	4020	7.41	21158	40800	5030	8.11	28968	48000	5300	9.06	34080
46°C	115°F	27270	3880	7.03	20179.8	35400	4710	7.52	26196	43500	4860	8.95	32190	
54°C	129°F	20000	4150	4.82	14200	23000	4250	5.41	16330	27000	4350	6.21	19170	





VRUI-60UC-M2B(54)

	Outdoor Temperature		Indoor Temperature											
			60°F (15°C)				70°F(21°C)				80°F(27°C)			
	°C	°F	Capacity	Power Input	COP	Capacity	Power Input	COP	Capacity	Power Input	COP			
Heating	-30°C	-22°F	28400	6220	4.57	27000	6350	4.25	26000	6410	4.06			
	-26°C	-15°F	33000	6370	5.18	32000	6700	4.78	31000	6560	4.73			
	-21°C	-5°F	38000	6610	5.75	37000	7000	5.29	35000	6820	5.13			
	-15°C	5°F	45000	6960	6.47	44000	7160	6.15	42000	7170	5.86			
	-8°C	17°F	50000	6660	7.51	49000	7100	6.90	45000	6870	6.55			
	0°C	32°F	55000	6470	8.50	54000	6600	8.18	52000	6660	7.81			
	8°C	47°F	55000	4400	12.50	56000	5300	10.57	52000	5050	10.30			
	15°C	60°F	60600	5300	11.43	60000	5400	11.11	50000	4400	11.36			
	20°C	68°F	60000	4700	12.77	60000	5100	11.76	50000	4100	12.20			
	24°C	75°F	54000	3400	15.88	54000	3800	14.21	50000	4000	12.50			
	Cooling	Outdoor Temperature		Indoor Temperature										
		60°F (15°C)				70°F(21°C)				80°F(27°C)				
°C		°F	Capacity	Power Input	EER	SHC	Capacity	Power Input	EER	SHC	Capacity	Power Input	EER	SHC
-15°C		5°F	30500	2380	12.82	20893	45900	3530	13.00	31442	54000	3650	14.79	36990
-10°C		14°F	30500	2420	12.60	21350	45900	3600	12.75	32130	54000	3720	14.52	37800
0°C		32°F	30500	2480	12.30	21289	45900	3680	12.47	32038	54000	3900	13.85	37692
5°C		41°F	30500	2600	11.73	21198	45900	3820	12.02	31901	54000	4050	13.33	36990
10°C		50°F	30500	2680	11.38	21350	45900	3900	11.77	32130	54000	4120	13.11	36990
18°C		65°F	30500	2720	11.21	21045	45900	4030	11.39	32130	54000	4250	12.71	37800
24°C		75°F	32100	3100	10.35	22406	45900	4180	10.98	32038	54000	4400	12.27	37692
30°C		85°F	32100	3250	9.88	22310	45900	4320	10.63	31901	55000	4650	11.83	38225
35°C		95°F	32100	3600	8.92	22470	45900	4790	9.58	32130	55000	5410	10.17	38500
41°C		105°F	30100	4100	7.34	20769	45900	6200	7.40	31671	54000	6650	8.12	37260
46°C		115°F	28000	4000	7.00	19880	36000	5000	7.20	25560	46000	5700	8.07	32660
54°C	129°F	21000	4250	4.94	14910	24000	4350	5.52	17040	28000	4450	6.29	19880	





USER NOTES AND INSTALLATION/SERVICE/MAINTENANCE NOTES

Installation Company: _____

Technician Name: _____

Phone: _____

Email: _____

INSTALLATION NOTES

Please record any questions or problems you have experienced as a unit history:

No.	Date	Notes	Asked Your Technician for Help?	Asked YMGI Tech. contacted for help?





This VRUI Indoor unit can work with any Outdoor Condenser Unit of any other major North American brand.





YMGI is dedicated to designing, manufacturing and distributing the highest quality, energy saving and environmentally friendly air conditioner and heat pump products, while providing the best service and support to all of our customers. Our mission is to help build a sustainable, efficient and Green world.

YMGI Symphony-Ductless & Ducted Heat Pump & Heat Recovery:

- **Symphony SOLAR DC Inverter**
(56) Single PV, (79) Single PH 12-18K Btu/h
(86) Single Zone All DC 09-24K Btu/h
(55) Multi Zone Solar VRF 3, 4, 8, 16, and 24 Ton.
- **Symphony SOLO DC Inverter**
(57)2,3 Single Zone 16 SEER, 09-36K Btu/h
(58)4, (78)1-Single Zone 18-23 SEER, 09-36K Btu/h
- **Symphony CHOIR DC Inverter**
(46)2 DC Inverter Multiple Zone 15 SEER, 2x09K and 2x12K Btu/h
(59)2S-DC Inverter Multiple Zone 16 SEER 6x09K to 9x09K Btu/h
(59)4-DC Inverter Multiple Zone 21 SEER 2x09K to 5x12K Btu/h
- **Symphony VRF - DC Inverter HP, Heat Recovery, and Solar. Up to 64 zones.**
- **Symphony HARMONY-Packaged Self-Contained**
42"x16" PTAC/PTHP Electric Heater or Hot Water Coil, and VPAK
- **Symphony CONDUCTOR-Split Type Condensing Units**
Side Discharge VRUI & VRUO

YMGI Group
601 Arrow Ln, O'Fallon, MO 63366
www.YmgiGroup.com
Tel: 866-833-3138 • Fax: 866-377-3355
Email: info@YmgiGroup.com

Unit appearance and specifications are subject to change without notice.
Copyright ©2020 YMGI Group

