



YMGI, Engineered Comfort Products for A Sustainable and Efficient Green World!

## INSTALLATION INSTRUCTIONS & USER MANUAL

### DC INVERTER MULTIPLE ZONE (59)4 CH SYMPHONY CHOIR OUTDOOR UNIT

**Model Numbers:**

- WMMS-30CH-V2B(59)4
- WMMS-36CH-V2B(59)4
- WMMS-42CH-V2B(59)4
- WMMS-48CH-V2B(59)4
- WMMS-60CH-V2B(59)4



Thank you for choosing this YMGI product. Please read the owner's manual carefully before installation and operation, and retain for your records and future reference. If you need a replacement copy, please contact your local agent or visit [www.ymgigroup.com](http://www.ymgigroup.com) to download a current electronic version.

### NOTICE

This product is designed and manufactured to be free from any defects in material and workmanship during normal use and maintenance. Installation, operation, maintenance and repair must follow all standards and professional practices for regular cooling and heating equipment, such as NEC, State, or Local Codes and all related documents/manuals provided by YMGI. Failure to follow and adhere to all codes and documentation can cause damage to equipment, property even personal injury.

**Installer:** Currently licensed/certified HVAC technicians only. Must Read the manual and all provided documents prior to installation. Complete and fill out all required information on the warranty registration card.

**User:** Retain this manual and all supplied documents for your records and future reference.

**Service:** Use this manual for information concerning servicing and maintenance of this product.

### SAFETY WARNING

Only qualified technicians should install and service this equipment. The installation, startup, operation and servicing of this equipment can be hazardous and requires a HVAC professional who has been trained, licensed and certified. Installations, adjustments or any equipment alterations done by an unqualified person could result in serious injury and even death. When working on the equipment, observe all precautions in the provided documents, on the tags, stickers, and labels that are attached to or placed on the equipment.



### TABLE OF CONTENTS

Introduction ..... 3

Note From YMGI – **Must Read** ..... 5

Installing Technician/Contractor's Responsibilities ..... 7

Limited Product Warranty ..... 8

Limited Product Warranty Registration Card ..... 10

Why Does YMGI Group Require Installation and Service to Be Performed  
100% By Currently Licensed or Certified HVAC Technicians/Contractors ..... 11

Suggestions to Aid You in Hiring an HVAC Contractor ..... 11

Introduction to Mini Splits ..... 12

System Diagram and Compatible Indoor Units ..... 15

System Layout & Installation Clearance ..... 16

Unit Dimensions ..... 20

Specification Sheet ..... 21

EXTENDED RATINGS-Variou s Indoor and Outdoor Temperatures ..... 23

Recommended Tools for Installation ..... 28

Installation Location Selection ..... 29

Installation-Indoor Units..... 30

Connect Refrigerant Pipes Between Indoor and Outdoor Units ..... 32

Piping Guide ..... 33

Refrigerant System Diagram ..... 34

Connection of Wires ..... 36

Wiring Diagrams..... 40

Do Not Cross Pipe or Cross Wire ..... 42

Accessories..... 43

Vacuum Testing and Charging ..... 44

System Inspection and Trial Run..... 45

Basic Functions of the System ..... 47

About Clashing Mode Functions..... 50

Protection Signs and Error Codes ..... 51

Checking Units Prior To Contacting Your Technician ..... 53

R-T Conversion Tables ..... 55

User Notes and Installation/Service/Maintenance Notes ..... 58



## Introduction

Read this manual carefully, making sure you understand all the instructions, practices and procedures contained in this manual. Be sure you are familiar with all the safety advisories that appear throughout this manual. Your personal safety depends upon your observance of all precautions contained in this manual.

Safety advisories appear throughout this manual and your personal safety and the proper operation of this appliance depend upon the strict observance of these precautions.

The 3 types of advisories are defined in the following table:

<b>⚠ WARNING</b>	Indicates a potentially hazardous situation which if not avoided could result in serious injury or even death.
<b>⚠ CAUTION</b>	Indicates a potentially hazardous situation which, if not avoided, could result in minor or moderate injury. It could also be used to alert against unsafe practices.
<b>NOTICE</b>	Indicates a situation that could result in equipment or property-damage only. It can also be used to call attention to important details within this manual.

## Important Environmental Concerns

Studies have shown that certain man-made chemicals can affect the earth's stratospheric ozone layer when released into the atmosphere. Refrigerants that contain Chlorine, Fluorine and Carbon (CFCs) and those containing Hydrogen, Chlorine, Fluorine and Carbon (HCFCs), may affect the ozone layer. Not all refrigerants have the same potential impact on the environment. YMGI Group advocates for the responsible handling of all refrigerants including industry replacements for CFCs such as HCFCs and HFCs.

## Responsible Refrigerant Practices

YMGI Group believes that responsible refrigerant practices are important to our customers, the HVAC/R industry and the environment. All HVAC/R technicians who handle refrigerants must be certified. The Federal Clean Air Act (Section 608) sets forth the requirements for handling, reclaiming, recovering and recycling of certain refrigerants, the equipment and tools necessary to perform these service procedures. In addition, some states or municipalities may have additional requirements that must also be adhered to for responsible management of refrigerants. HVAC/R technicians must know the applicable laws and follow them.

## Disposal Notice

Do not dispose this product or its components as unsorted municipal waste, as they contain items that may require special treatment. Contact your local waste management company for details.

### **⚠ WARNING**

#### **Proper Field Wiring and Grounding Required!**

Failure to follow established electrical codes can result in death, serious personal injury and property damage. All field wiring **MUST** be performed by qualified personnel. Improperly installed and grounded field wiring poses **FIRE** and **ELECTROCUTION** hazards. To avoid these hazards, you **MUST** follow the requirements for field wiring installation and grounding as described in this manual and by NEC and your state and local electrical codes.

### **⚠ WARNING**

#### **Personal Protective Equipment (PPE) Required!**

Failure to wear proper PPE for the job being undertaken could result in serious injury or even death. Technicians must take the necessary precautions to protect themselves from potential electrical, mechanical, and chemical hazards and **MUST** follow all precautions in this manual and on the tags, stickers, and labels, as well as the instructions below:

- Before installing or servicing this unit, technicians **MUST** put on all PPE recommended for the work being undertaken. **ALWAYS** refer to appropriate Material Safety Data Sheets (MSDS) and Occupational Safety and Health Administration (OSHA) guidelines for proper PPE.
- When working with or around hazardous chemicals, **ALWAYS** refer to the appropriate MSDS sheets and OSHA guidelines for information on allowable personal exposure levels, proper respiratory protection, and handling recommendations.

If there is a risk of arc or flash, technicians **MUST** put on all PPE in accordance with NFPA 70E or other country-specific requirements for arc flash protection, **PRIOR** to servicing the unit.

## Copyright

This document and the information contained therein are the sole property of YMGI Group and shall not be used or reproduced in whole or in part, without the written permission of YMGI Group. YMGI Group reserves the right to revise this manual at any time and to make changes to its content without obligation to notify anyone about any modifications, revisions or changes.

### **⚠ WARNING**

- Instructions for installation and use of this product are provided by the manufacturer.
- Installation must be performed by authorized and licensed personnel only and in accordance with all the requirements of this manual, the NEC, CEC and any state and local codes.
- For safe operation of this unit, please read and follow all instructions carefully.
- The total operation capacity of the indoor units should not exceed 120% of the total capacity of the outdoor units if all indoor units must operate at their peak capacities all the time. Otherwise, the heating and cooling operation will be diminished and less efficient which could damage the units.
- Any person responsible for system operation or system maintenance should retain this manual for reference.
- If the unit fails to operate normally, please contact your authorized system installer or HVAC professional as soon as possible and provide the following information:
  - Data on the unit (model number, serial number and owner's name).
  - A detailed description of the unit's problem before and after the problem occurred.
- To avoid personal injury or property damage, do not disassemble the unit yourself. If disassembly is required to check the unit, contact your authorized system installer or HVAC professional as they have the experience and training necessary to perform this task.

**Note:** Each unit has been thoroughly tested to ensure it operates correctly before leaving the factory.

## Basic Cautions and Warnings

### **⚠ CAUTION**

All units shall be installed by an experienced HVAC licensed contractor or technician. Read all manuals before installation, startup and operation.

### **⚠ CAUTION**

All NEC, state, local codes and installation instructions must be followed for all units, otherwise, the unit warranty will be void and could result in serious damage to people or property.

### **⚠ WARNING**

YMGI Group is not responsible for any damage or loss due to Do-It-Yourself (DIY), self-installation or any improper installation, improper operation, improper service or natural disasters of any kind.

### **⚠ WARNING**

Do not connect power to the unit until all wiring, tubing and all unit inspections and testing have been completed. Ground the unit according to the instructions and adhering to NEC, state and local codes.

### **⚠ WARNING**

All wiring connections must be correct and secure. Loose wire(s) or improper contacts may cause arcs or overheating which can result in a fire hazard.





## Note From YMGI – Must Read

Dear Customers, Purchasers, Installers, and Contractors

Thank you for choosing an YMGI product.

All YMGI's products are fully tested and have passed rigorous safety, performance and manufacturing standards before being packed and shipped. YMGI only uses suppliers that meet our strict standards for high quality and performance for all parts. YMGI also recognizes a quality installation is equally important therefore your system must be installed by a licensed HVAC professional. A quality installation ensures your unit will operate at its highest efficiency and peak performance for many years of worry free comfort; while a poor installation can result in unit failure and cause the unit to operate inefficiently, either immediately or over time, resulting in costly repairs.

Because a quality installation is so critical, YMGI provides detailed information in our manuals which will aid the installing technician and the owner of the unit(s).

At YMGI our goal is to ensure that your YMGI units are installed properly and correctly from the beginning.

The YMGI equipment you purchased is either a split-type or a self-contained cooling/heating system. These types of systems require a certified and licensed HVAC professional technician for proper installation. Only a certified and licensed HVAC professional technician will have the knowledge, experience, and attention for all required details to perform a complete and successful installation. This equipment is different from a window or portable type air conditioners you can purchase from local retail stores such as Home Depot, Lowe's, Sears, etc. which the manufacturer may not require certified and licensed personnel to install.

Reading and following YMGI Group recommendations and requirements contained in the following pages and other documents, is the first step to help ensure a smooth installation and proper operation of your unit for many years.

### **⚠WARNING**

YMGI doesn't recommend nor allow any do-it-yourself (DIY) installation (partially or fully). Due to the complexity of the installation of this product most DIY installations usually have problems, either immediate or near future. These problems can cost more to fix than any upfront savings. **YMGI warranty doesn't cover any DIY units.**

If you have any questions about your unit or if the unit has a problem, you should first check the manual. If you can't find a solution, then contact your local installer or service technician to schedule a service appointment. The technician can physically inspect the unit. If at the time of inspection, the installer or service technician has any questions about the unit, they can contact YMGI technical support division directly at:

**Toll Free Number: (866)833-3138 or Email: [techsp@ymgigroup.com](mailto:techsp@ymgigroup.com)**

### **IMPORTANT: YMGI Group is the MEDIA AUTHORITY:**

YMGI Group, located in O'Fallon, MO 63366 is the author of all media produced for its products and is the only party able to give any additional explanation for any data, definitions and or descriptions found within any of its media, including but not limited to YMGI product brochures, manuals, pamphlets, catalogs, and videos. YMGI's distributors, installers, dealers, agents, customers or any other third parties will not supersede YMGI in anyway concerning YMGI-published materials and their meaning. Any concerns or questions arising from YMGI distributors, installers, dealers, agents, customers or any other third parties, should be presented directly to YMGI. YMGI will respond to any concerns or questions, if necessary, about any of its media in writing.





## **NOTICE**

- Be sure to only hire a certified and currently licensed HVAC Company to complete 100% of the installation so that all details of the installation are performed correctly and completely.
- Be sure to have ONLY the licensed HVAC professional perform all aspects of the installation. Factory Warranty will be void if any portion of the installation is not performed by a licensed HVAC contractor/technician. DIY or partial DIY will also void ALL factory warranties.
- When hiring an HVAC technician that is offering their services as a "side job" and not hiring a licensed HVAC company may pose possible risk. This may result in an incomplete or unsatisfactory installation, no guarantee for workmanship and lack of maintenance and further service to your unit.
- Have the installation technician read in full the installation manual and all supplied documents for the product model you purchased. Details within the documentation contributes greatly to the success and quality of the installation. Experience with other manufacturers may not be applied fully to another manufacturer, although there will be similarities there will also be differences. Ignoring the provided installation procedures is an act of negligence and may cause unit failure or damage which could be irrevocable and permanent.
- It is possible for a licensed contractor/technician to make a mistake during the installation. YMGI doesn't supervise nor is able to control the contractor/technician's installation. It is critical that the installer take each variable into account during the initial installation. This will ensure a complete and professional installation and that all units work properly.

## **⚠WARNING**

**The following will damage the unit and its key components resulting in loss of factory warranty:**

1. Any foreign substances introduced into the system because of failure to seal the ends of the refrigeration piping before pulling the piping through any structures at time of installation.
2. Not installing an oil P-trap in the copper suction line where the indoor unit is located 18 feet or more below the outdoor unit.
3. Cross piping and/or cross wiring of any units including more than one single zone or a multi zone system.
4. Not conducting a positive leak check prior to the negative leak check.
5. Not conducting a positive leak check by charging the system with dry-nitrogen 350 PSI to hold for 3+ hours, and performing soap bubble testing.
6. Not conducting a negative leak check by evacuating the copper lines for 30 minutes for each zone. Vacuum must be held at 500 microns or better for at least 60 minutes, starting 60-minute timer after the vacuum pump is turned off.
7. Not selecting the correct size of wire or circuit breaker.
8. Not answering ALL questions in the technician's checklist located inside the warranty registration form.

## **⚠WARNING**

**The following may be overlooked, ignored, or considered unimportant during your installer's installation, but will cause your unit to underperform and may cause unit failure.**

1. Any kinks in or improper bending of the copper piping.
2. Any poorly formed flares or not centering the flare with the flare nut, or not tightening all connections.
3. Not testing each indoor unit individually.
4. Not reading technical data (temp/time/pressure/current) after the system is stabilized (normally the compressor needs to run at least 10 minutes before reading the data). If the data is read too early may lead to inaccurate assessments about the unit.

In an effort to help protect our customers from possible faulty installations that can lead to premature unit failure, YMGI provides the above information for you and the technician. You can observe while your system is being installed, even though your observation is not a guarantee your system is being or has been installed properly and professionally. With the information provided above, you will know some things to look for and questions you can ask. If at any time you feel there may be an issue with the installation, please have your technician contact YMGI at (866)833-3138 x 703 with any questions, issues or concerns you may have.





## INSTALLING TECHNICIAN/CONTRACTOR'S RESPONSIBILITIES

1. Discuss with the customer detailed information about the structure to be conditioned, local weather (typical design, extreme temperature/humidity conditions, cooling and heating hours), previous and existing HVAC equipment (if any), usage and dependence on new HVAC equipment or YMGI products.
2. Performing a cooling/heating load calculation by using commercially available professional programs/methods such as Right-J (Manual J) for residential HVAC applications and Right-CommLoad (ASHRAE RTS/CLTD) for light commercial and commercial HVAC applications.
3. Contact your YMGI distributor/sales department or contact the manufacturer directly to obtain additional information to fully understand your YMGI products, including but not limited to product features, cooling/heating performance at standard ratings/conditions and extreme conditions, allowed indoor and outdoor temperature and humidity ranges, installation, operation, maintenance, service, warranty, parts and any other issues pertaining to YMGI products.
4. Select the correct (most suitable) YMGI product unit models and accessories necessary for your HVAC applications and list them in the proposal/quote, in writing, on company's quotation form or letter head, based upon the information you collected from 1), 2) and 3).
5. List your currently valid HVAC license number and EPA number in your proposal/quote.
6. Make sure you are the only party to perform the entire installation and you will not sub-contract any part of the installation to any non-licensed parties or persons. You will be solely responsible for the entire installation that you have been contracted.
7. Make sure you have all the materials you need to properly, completely and correctly finish the installation. The YMGI units and accessories may be just a portion of what you will need for the project. When support issues arise, remember YMGI employees and YMGI distributors/sales, dealers and agents are not installers and may only provide suggestions. You are the only decision maker to determine what other materials you need to complete the installation.
8. When connecting electrical wires, follow all NEC, state and local codes and ensure the installation of all YMGI units and accessories meet these requirements.
9. Connect the unit to a correctly sized electrical power source. If the unit is installed in an area where lightning or storms occur frequently, a correctly sized and type of power surge protector must be installed between the outdoor unit and the power source.
10. Select the correct types and sizes of HVAC circuit breakers, disconnect switch boxes, wires and conduit from circuit breaker to disconnect box and then from disconnect box to outdoor unit.
11. Select the proper location for installing indoor units and outdoor units with all factory requirements being followed (cooling/heating air inlets and outlets are not blocked or restricted, mounting structure is secure, installation for convenience is considered, allow adequate clearance for maintenance/service and all applicable codes are met).
12. Cap/tape the two ends of every copper line before running them through any structure to keep any foreign substances from entering the pipe causing contamination. Label them A-A, B-B, C-C, D-D, or any other identifying marks on each pair of copper lines and wiring cable sets to keep from cross-piping or cross-wiring in multiple zone installations or where pipes for different single zone systems are close to one another.
13. Secure the wiring cables that connect between the indoor unit and outdoor unit, following all applicable NEC, state and local codes for your installation. If there is no special NEC, state or local codes to govern how these wires are to be installed, you can tape/cable tie them along with insulated copper line.
14. Tighten all pipe and wire connections ensuring there is no leakage or false connections.
15. Conduct a positive pressure leakage test, checking each of the inter-connecting copper lines between each indoor unit and outdoor unit by charging with dry-nitrogen at the outdoor unit's service port (note: do not back-seat stopping valve). A liquid soap solution shall be applied at all pipe connections to check for leakage. A 1/4" - 5/16" hose/valve adaptor may be needed if you have a 1/4" traditional manifold hose connection.
16. If there is no positive leaking, then conduct a negative pressure leakage test, checking all inter-connecting copper lines between each indoor unit and outdoor unit by pulling vacuum at the outdoor unit's service port (note: do not back-seat stopping valve) and checking that the vacuum level of 500 Microns can be held for at least 60 minutes.
17. If there is no leakage found at any of the refrigeration pipe connections, flip up the indoor unit's face panel and remove filter, carefully pour some clear water onto the up-right aluminum coil surface to test if the water can drain out of each the indoor unit's freely without finding any leakage.
18. If there is water leakage found, locate the source of the leak and correct it. Only after everything is clear, engage the correct electrical power to the system.
19. Then back-seat stopping valves of the outdoor unit to release refrigerant from the outdoor unit into the inter-connecting pipes and indoor unit.
20. Make sure both the indoor unit and outdoor unit are powered on correctly, operating the indoor unit in fan mode first. Then move on to test cooling, dehumidifying/drying, heating and other modes.
21. Read refrigerant pressures and pipe/valve temperatures only after the system is stabilized (normally 10 minutes after cooling/heating mode is started successfully). Record this data into the technician checklist in the lower half section of the Limited Product Warranty Registration Card/Form.
22. Adjust refrigerant charging level (remove refrigerant if pipe is shorter, the temperature is colder; add refrigerant if pipe is longer the temperature is warmer), following the manufacturer's instructions. If the average pipe length is shorter or longer than 25' and pressure/temperature readings at the outdoor unit service valves are not falling into normal ranges.
23. Explain to the user/owner about proper unit operation and maintenance. Leave your contact information to allow them to reach you. If the customer finds the unit doesn't work properly and cannot resolve the issue themselves, check the customer's units/parts/accessories and correct the issue if there is one. Communicate with YMGI-technical support line at (866)833-3138 x 703, if further help necessary.

Following these requirements will aid in ensuring that the units to be installed meet general HVAC practicing standards and necessary factory requirements. Finding any possible problems early, preventing any further damage to the unit will help to ensure a properly working unit for many years.





## LIMITED PRODUCT WARRANTY

Once the installation and successful testing of the system has been completely performed by a qualified licensed/certified HVAC technician/contractor, the registration card/form is filled out completely and correctly, and filed along with a valid installation invoice from the contractor within 7 days of the original installation, the following standard **Limited Product Warranty** is qualified: **7-years** on the **compressor** and **2-year** on **PARTS ONLY**. There is **no labor coverage**.

YMGI products are designed and manufactured free from defects in workmanship, and materials for normal use. However, if for any reason, including occasionally transporting between YMGI factories/warehouses and your delivery location, you discover the unit has issues, YMGI Group will help field a solution by following YMGI's established warranty procedures:

**Compressor:** YMGI will warrant the compressor of an YMGI-validated and approved warranty filing, for a period of 7 years from the date of successful installation at its original installation location.

**Parts:** YMGI will warrant parts of an YMGI-validated and approved warranty filing, for two years from the date of successful installation at original installation location.

All warranty compressors and parts replaced will become the sole property of YMGI Group and must be returned to YMGI Group upon request. Warranty parts may be new or refurbished. All parts are tested and approved before shipping.

**At no time does YMGI Group warrant labor cost of any type. Warranty will start from the date of successful installation at original installation location, or 90 days as of original shipping date from YMGI Group, whichever comes first.**

***This is a standard limited liability warranty and DOES NOT cover the following:***

- Any damage or repairs to properties, or persons as an incident of or consequence of improper faulty transportation, installation, operation, maintenance or service.
- Any damage caused by frozen or broken water hoses or refrigeration pipes in the event of equipment failure.
- Any damage due to floods, fire, wind, lightening, accidents, corrosive atmosphere or any other conditions beyond the control of YMGI Group.
- Any damage due to interruption or inadequate electrical service to equipment.
- Any products that are installed outside the US or Canada.
- Any unit that has been moved from its original installation address.
- Any labor costs associated with the installation or service of the unit.
- Poor unit performance due to improper unit selection (SEER, Unit size).

**To validate the above warranties, ALL of the following conditions must all be fulfilled:**

1. The unit was fully (100%) and successfully installed by a licensed or certified HVAC technician.
2. The unit was installed following all NEC, state and local codes.
3. The unit was installed following all the information within the Instructions and User Manuals provided by YMGI Group.
4. ALL fields, especially the technician-checklist, of the **Limited Warranty Registration Card/Form** were filled completely by the installing technician and signed by both the installing company technician and the unit owner.
5. The **Limited Warranty Registration Card/Form** and a copy of the original installing company's invoice have been received by YMGI Group-Warranty Dept., POB 1559, O'Fallon, MO 63366, within 7 days of successful installation.

**No warranty filing will be validated or approved, if any one of the above conditions are not met.  
Product registration doesn't guarantee the validity of this limited warranty statement.**





## Steps to follow for warranty part replacement:

1. The installing or service technician must contact YMGI tech support at 1-866-833-3138 ext. 703 from the installation location to check and confirm with YMGI Technical support the exact part(s) needed to fix the problem(s).
2. YMGI will check the customer's warranty filing. There will be no charge for Parts with a validated and approved warranty. Any Parts that have not been validated and approved or have an invalid warranty filing resulting in an unapproved warranty request, will be charged accordingly.
3. ***YMGI will ground ship out the parts ASAP. Expedited shipping is available at the customer's expense.***
4. Replacement parts that have an approved warranty registration are to be warranted for the remainder of the 2-year on parts and a 7-year compressor warranty. Purchasing of replacement parts without a valid warranty filing or unapproved warranty request, will be sold as is and are not covered by any warranty.

YMGI is continually improving products with various engineering changes and these changes are made without prior notice. Such improvements or changes include but are not limited to product specification, appearance, functionality, size, packaging, etc. These improvements or changes will not void the limited warranty stated herein. YMGI is the final authority concerning this warranty policy.





# LIMITED PRODUCT WARRANTY REGISTRATION FORM

Top Portion and Keep Copy A is for YMGI Internal records. Copy B is for Installer to Fill out and Mail back to YMGI. Bottom Copy C for Customer records.

For YMGI Use Only	Date:	Shipping Packing List Number:	Registration Card Serial No.
	Did the Company Pay YMGI:	Unit(s) Work Successfully:	Yes/No
	Installation Invoice Attached to the Registration Card	Hired YMGI Recommended HVAC Contractor/Technician?	Warranty Approved
Outdoor Unit Serial Number :	Indoor Unit Serial Numbers:	Unit 1	Unit 6
		Unit 2	Unit 7
		Unit 3	Unit 8
		Unit 4	Unit 9
		Unit 5	Unit 10

**Contact at Installation Location:**

Name:	Phone:	Fax:
Address:	Email:	
City:	State (Province):	Country:

**Contact of the Installing HVAC Contractor/Technician:**

Technician Full Name (Print):	Phone:	Fax:
HVAC Technician's Company:	Email:	
Company Address:	City:	State (Province):
Currently Licensed/Certified HVAC Technician License or Certification Number:	License Approved/Certified by:	
Official Phone # to Check the License Validity:		

Checklist for Installing HVAC Technician to Verify Installation Quality, and for Warranty Processing Purpose (If not filled out completely by technician, warranty will be voided)

1) Did you install the whole system? If not, please note below.	15) Where is the outdoor unit located?	Is the outdoor unit anchored to ground or secured onto wall bracket?
Yes No % of installation done by you (HVAC technician).	Ground wall balcony roof other location or pad	Yes No
2) What had been done, prior to your arrival?	16) Have you checked to make sure there is no cross-piping and/or cross-wiring between any two indoor units (zones)? What was your procedure?	
3) Did you read the User Manual and Installation Instructions before starting the installation?	17) Were the refrigerant pipe ends capped or sealed, prior to running them through structures to keep debris from entering the copper lines?	
Yes No	18) Have you checked both cooling and heating on all indoor units individually to ensure proper function?	
4) Who unpacked the unit and accessory boxes to check for damage?	Yes No	
5) Supply electrical power V/Ph/Hz measured at wiring terminal block of	19) Did you charge the inter-connecting copper pipes and indoor unit with nitrogen to check for positive leakage (pressures 150-200PSI), before conducting a vacuum leak check?	
Indoor unit: Outdoor unit:	Yes No	
6) Incoming electrical power V/Ph/Hz measured at terminal blocks of	20) Did you vacuum correctly to check the connecting pipes and indoor unit for leakage? What was the micron gauge reading, for how many minutes?	
Indoor unit: Outdoor unit:	21) Did you check the compressor's start and stop sequences to determine proper functionality?	
7) Wire gauge, length and terminal colors between circuit breaker/disconnect switch to outdoor unit:	Yes No	
8) Wire gauge, length and terminal colors between each indoor and outdoor unit:	22) If copper length were not made to the supplied or recommended refrigerant pipe length, how much refrigerant added or deducted?	
Unit A Unit B Unit C Unit D	23) Measured refrigerant pressures at outdoor service suction valve, when unit was stabilized.	
9) The size of HVAC circuit breaker/fuse or disconnect switch to the outdoor unit:	Heat pump (PSI): Cooling (PSI): Outdoor Ambient Temp. (°F):	
10) Are the inter-connecting wires and copper lines between indoor and outdoor units installed/covered/protected by line set covers, or anything else?	24) What were the measured temperatures (probe not touching any metal):	
11) What is the refrigerant pipe length between each indoor unit and the outdoor unit?	At cooling: indoor return air °F Discharge air °F and outdoor °F	
Unit A Unit B Unit C Unit D	At heating: indoor return air °F Discharge air °F and outdoor °F	
12) Where is/are the indoor unit(s) located? (Bedroom, kitchen, etc.)	25) Have you checked all unit functions with customer present, and all functions are working correctly?	
Unit A Unit B Unit C Unit D	Yes No	
13) What is the elevation difference between each indoor unit and the outdoor unit?	26) Did you show the user how to operate the unit? Did he/she understand you?	
Unit A Unit B Unit C Unit D	Yes No Yes No	
14) Did you check the indoor unit for condensate leakage and refrigerant leakage, before and after connecting them?	27) Do you provide regular one-year free technical service for this installation?	
Yes No	Yes No	
Installation Finished and Unit Works Successfully.	Installation Finished and Unit Works Successfully.	
Print Name of Installation HVAC Technician:	Print Name of Owner:	
Signature:	Signature:	
Date and time:	Date and time:	

By signing above, I acknowledge the liability and responsibility for any false statement or omission of facts, and I authorize YMGI to verify the details provided above, and make its decision on warranty. I understand our filing or filling out of the warranty card/form DOES NOT imply automatic warranty approval, because warranty is approved only to qualified and successful installations by a qualified HVAC technician. I understand that the warranty (if approved) is a standard 5 year compressor and 1 year parts only, and does not include any labor coverage. I agree to and will follow all the contents contained in the Limited Product Warranty Policy of YMGI, and no other entity, stated in public, including but not limited to manuals, web site, email, etc.

Important Note: A copy of the installing HVAC company's invoice to show all their work details, your payment proof, center copy B of this registration card filled out after a successful installation, all three (3) MUST be mailed together to Warranty Dept., YMGI Group, POB 1559, O'Fallon, MO 63366, for warranty processing. Customer keeps bottom copy C. YMGI will check against copy A that was kept at YMGI.





## WHY DOES YMGI GROUP REQUIRE INSTALLATION AND SERVICE TO BE PERFORMED 100% BY CURRENTLY LICENSED OR CERTIFIED HVAC TECHNICIANS/CONTRACTORS?

### 1. Expertise and Safety:

They have the training and experience to accurately and safely install and service your equipment. The equipment runs with high-pressure refrigerant, oil and electrical current. The copper lines must be installed properly to prevent leakage and foreign substances from contaminating the refrigerant system.

### 2. You will save money in the long run:

If any problem occurs with the unit that has been fully installed by a currently licensed or certified technician/contractor, contact the original licensed or certified HVAC technician to evaluate the unit as they have the training and experience to correct the problem quickly and efficiently. A technician may be unwilling to repair an issue on a unit that they did not install. If you do find a technician willing to perform this service, there is an increased possibility of higher service fees, increased service visits, or delayed service from that technician.

### 3. It's the law!

The federal, state and/or local government and authorities have various governing laws or regulations, guidelines, ordinances, etc. These laws may require only licensed or certified professionals can install and service this type of high pressure HVAC equipment.

## SUGGESTIONS TO AID YOU IN HIRING AN HVAC CONTRACTOR:

1. Hire a currently practicing, licensed/certified HVAC professional technician/contractor. Technicians, who are no longer practicing (retired, etc.) in this field, may not have current technical knowledge or may lack experience on the equipment you have purchased.
2. Hiring a licensed technician to install your unit as a "side job" and not hiring a licensed HVAC company may pose possible risk. This may result in an incomplete or unsatisfactory installation, no guarantee for workmanship and lack of maintenance and further service to your unit.
3. Hire a technician/contractor who services customers in your local area and one you are familiar with. Local contractors have a faster response time and it will be easier for you to determine if they are reputable.
4. Use only a reputable licensed/certified HVAC installation professional to prevent any unexpected charges because of unethical business practices.
5. Check their references, verify they provide professional service for their customers. N.A.T.E or A.C.C.A certified technicians are strongly recommended.
6. Some contractors/technicians may not feel comfortable about installing equipment that has been purchased by someone other than themselves. They prefer to purchase and install the equipment themselves. You can contact YMGI directly to check and see if there are contractors in your area who have installed our products or any similar products.
7. Ask for a detailed quote for the complete installation project. A flat rate quote is the safest contract for both you and the contractor.
8. Local HVAC technicians may charge you on a project basis or on an hourly basis. It has been our general experience; **a full single head installation normally can cost \$800 to \$1500.** These costs are estimates, and your actual costs may differ due to your specific job requirements and installation location.
9. Number of hours can vary depending upon each individual situation, some factors are, but not limited to:
  - Difficulty or complexity of securely installing the indoor unit.
  - Difficulty or length of the inter-connecting pipes and wires to be installed.
10. A successful installation is dependent on all these suggestions and all the necessary steps are followed.
11. If the contractor(s)/technician(s) are experienced with the systems/brands you purchased. **You might save on the installation cost, but remember to always ask for and verify references.**
12. The contracts should list and detail all work to be performed and the standards they will follow. Some contractors are willing to include a 1-year installation/service warranty at no extra charge. Check to see if this is an available option. If available, make sure it is included in the contract.
13. Verify and confirm the installation is completed and all the unit functions have been tested and working properly. All items on the checklist should be checked and clearly marked in the warranty registration card/form, prior to paying the contractor in full.

The cost of not having your unit professionally installed can be more expensive than the additional cost of hiring a certified contractor. Protect your investment and warranty eligibility by doing it right the first time.





**⚠ WARNING****Safety Precautions**

1. Follow these instructions to complete the necessary installation process. Carefully read this manual before installation and unit startup or servicing.
2. Wire size of power cord should be properly sized to meet the required electrical loads. Should the power cord get damaged, the power cord should be replaced with a manufacturer approved cable.
3. After connecting the power cord, attach the electric box cover and secure properly.
4. Always meet the nitrogen charge requirements when welding pipes.
5. Never short-circuit or cancel the pressure switch as this will result in damage to the unit.
6. Connect the wired controller before energizing, otherwise the wired controller cannot be used.
7. Before using the unit, verify the piping and wiring are correct. This will avoid water leakage, refrigerant leakage, electric shock, or fire etc.
8. Do not insert fingers or objects into the air outlet or inlet grille.
9. Open a door or window for ventilation for allowing fresh air to enter the room to avoid depleting the oxygen while gas/oil supplied heating equipment is used during the installation.
10. Never start up or shut off the unit by means of directly plugging into or unplugging the power cord from the power outlet.
11. Turn off the unit after it runs at least five minutes, otherwise it will influence the oil return of the compressor.
12. Do not allow children to operate this unit.
13. Do not operate this unit with wet hands.
14. Turn off the unit or disconnect the power supply before cleaning the unit. This will avoid possible electric shock or personnel injury.
15. Never spray or splash water towards the unit. This can cause a malfunction in the unit or can result in electric shock.
16. Do not expose the unit to moist or corrosive environments.
17. While operating in cooling mode, do not set the indoor unit's room temperature too low.
18. YMGI Group recommends that only properly trained and authorized personnel be allowed to repair or service the unit. Improper repairs or servicing can result in electric shock or fire hazards. Please contact YMGI Group if you need help locating a qualified repair or service technician.
19. Before installation, check the power supply to ensure it is sufficient to meet and is in accordance with the requirements specified on the nameplate of the unit. Ensure the power overload is functioning correctly and make sure it is properly maintained.
20. Installation must be performed only by an authorized installer or HVAC professional in accordance with the requirements set by the NEC and CEC. Do not attempt to install the unit yourself. Improper handling may result in water leakage, electric shock, fire, and voiding of the warranty.
21. Be sure to use only approved accessories and parts to prevent water leakage, electric shock and fire.
22. Make sure the unit is grounded properly prior to connecting to power source, to avoid electric shock. Do not connect the ground wire to a gas pipe, water pipe, lightning rod or telephone line.
23. Energize the unit for 8 hours before operation. Turn off or disconnect the power within 24 hours to prevent short-cycling (to protect the compressor).
24. If refrigerant leakage happens in a confined space during installation, ventilate immediately. Poisonous gases can occur if the refrigerant gas is exposed to fire.
25. Volatile liquids, such as paint thinners or solvents if exposed to the unit's surface will cause damage to the surface finish. Only use a soft cloth along with a mild non-abrasive detergent to clean the outer casing of the unit.
26. If the unit does not operate normally or if you notice any type of burning odor, power off the unit and turn off the main power supply, then immediately contact your YMGI authorized repair service center or HVAC professional.

**NOTICE**

***YMGI Group will not be responsible for any personal injury or any property damage caused by improper or incorrect installation, improper service or maintenance or by not following the instructions listed in this manual.***

**DO NOT** pull on the power supply cords or refrigeration lines that are connected to the indoor and outdoor units. Install the power supply cords and secure them into position. PVC line set cover is recommended for the outdoor unit to protect against rain, sunlight and accidental damage.

**DO NOT** allow cold air to blow directly onto people for a prolonged period, as this could make people cold and uncomfortable.

**DO NOT** undersize any of the power supply wires.

**DO NOT** connect several units to a single breaker. Don't undersize or oversize the circuit breaker. A poorly sized circuit breaker can cause unit failure and even fire.

**DO NOT** wire or open a unit while the unit is running. Make sure to disconnect the power supply and switch off all circuits prior to inspecting or servicing the unit. Inspecting and servicing the unit while the power supply is connected, and the circuits are switched on could cause an electrical shock or fire.

**DO NOT** install the indoor unit near any cooking surfaces, in direct sunlight or any ventilation systems. Poor placement could decrease efficiency and waste energy.

**DO NOT** install the unit in places where there is exposure to flammable materials or gas.

**DO NOT** apply chemical solvents, flammable insecticides, or abrasive materials directly on the unit. Clean the unit only with a soft dry cloth.

**DO NOT** install the unit in a damp laundry room or near flammable gas. All units must be protected by a certified electrical circuit breaker in accordance with all safety and electrical codes.

**DO NOT** use the system for anything other than what it was designed.

**DO NOT** store or install the units near food, paint, or other chemicals.

**DO NOT** use the unit in cool or dry mode for prolonged periods where humidity is higher than 90%.

**DO NOT** operate the unit for prolonged periods without refreshing ambient air. Open a door or window periodically to allow in fresh air.

## BRIEF INTRODUCTION TO MINI SPLIT WALL MOUNT SYSTEM

Mini Split Wall Mount Systems are designed for high performance, easy installation and service. Each system consists of one or several indoor units and one outdoor unit, which are connected by one set or several multiple sets of interconnection refrigerant pipes and electric wires.

As shown in the following sample picture of outdoor unit, air is drawn through the coil from the rear side and then discharged from the front side. In cooling mode, air passing through coil is heated; in heating mode, air passing through coil is cooled.

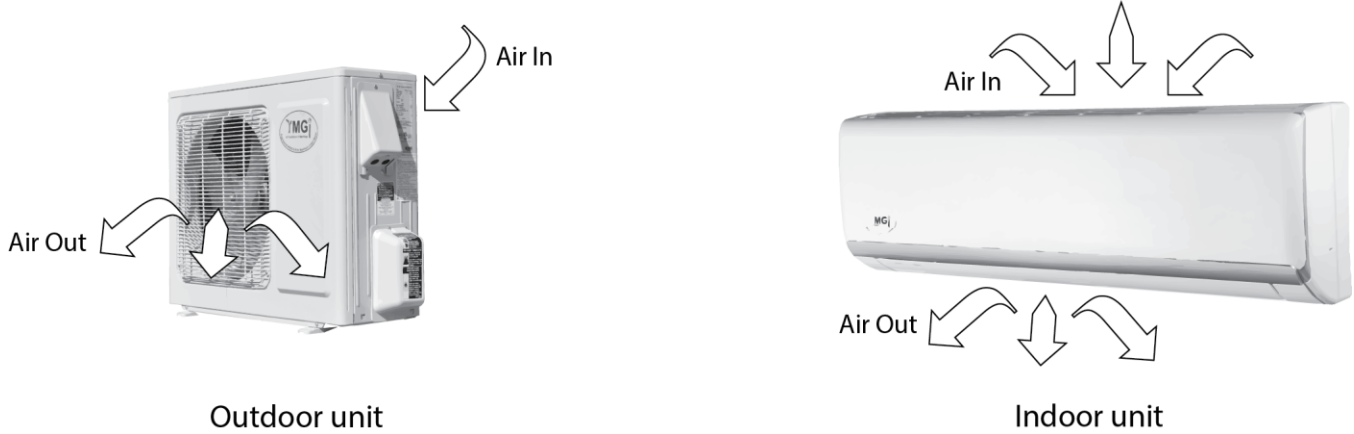

### Sample Wall Mount Mini Split System (For Continuous Engineering Improvement and Various Marketing Needs and Actual Part Availability, Unit Appearance Subject to Change or Update Continuously without Prior Notice)

Outdoor unit(s) provides the electrical and thermal power for the whole system. Electrical and thermal components such as compressors and motors and heat exchange coils and others, are incorporated into the cabinet in an optimized order. They can be either hung on the wall or installed on the ground. Once stacking or bracket kit is used, some outdoor units can be stacked 2 or 3 units high, depending upon unit size and applications. Air is discharged horizontally, quietly and smoothly. These units are a perfect fit in locations where installation and applications of general up-flow condensing units are limited, such as apartments, condos, lofts, multi-families and high-rise buildings and others named or unnamed.

Indoor unit(s) delivers the thermal and acoustical comfort to the rooms. Air is drawn through the coil from the front or topside and then discharged from the bottom. In cooling mode, air passing through coil is cooled; in heating mode, air passing through coil is heated. Air is filtered or treated by the built in mechanism (washable or enzyme equipped or electrostatic powered filter, varies from model to model), before being delivered into the room, with more than enough comfort and care, at a wide angle (swing or not, varies from model to model).



Apartments



Offices, Restaurants, Gyms, etc.



Homes

#### NOTES:

Since ductless system is not designed to incorporate or use with ducted return or discharge tunnels, one single-zone unit should NOT be used to take care of the cooling or heating load of more than one-story room. Several single-zone ductless systems or multiple-zone ductless systems shall be proper in this regard.

These units are designed for applications at:

- Residential
- Institutional
- Commercial
- Light commercial
- Industrial
- Hospital

# System Diagram and Compatible Indoor Unit Types

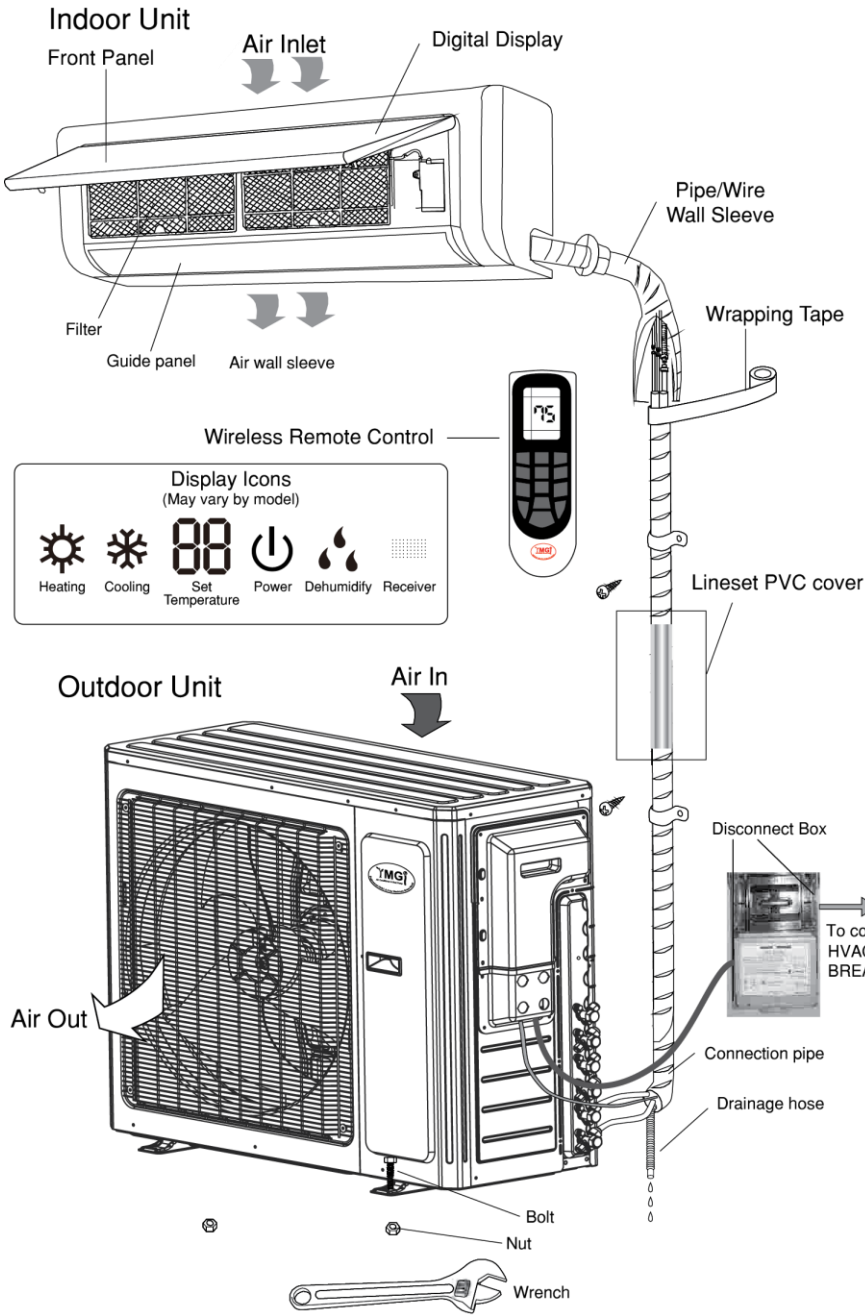

Wall Mount EW Indoor Unit



Recessed Fan Coil EF Indoor Unit

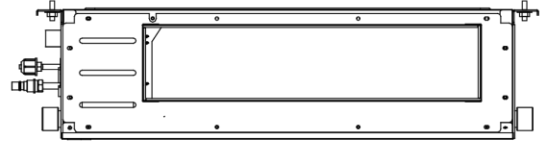

Ceiling Cassette Indoor Unit EC

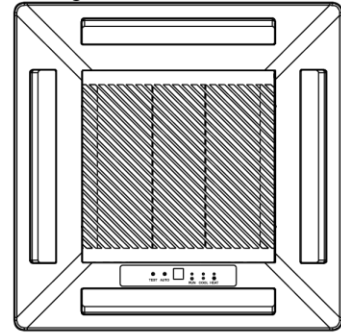

Console EL Indoor Unit

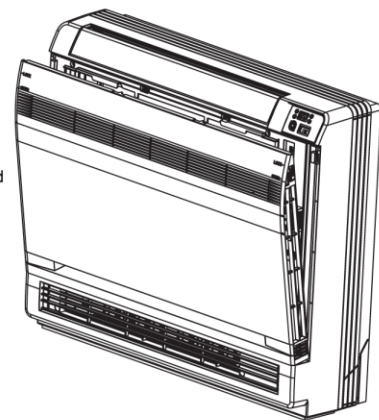

Floor/Wall Mount EU Indoor Unit

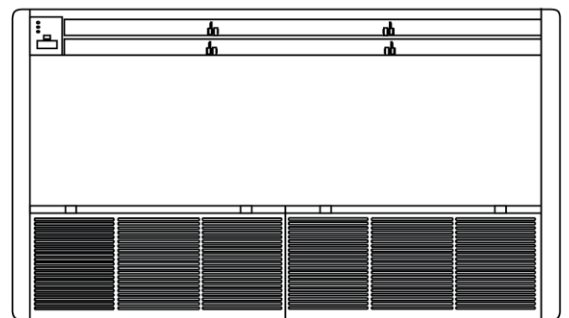

Notes: Actual unit or part appearance and installation may vary from illustration. Subject to continuous improvement and change without notice.

# SYSTEM LAYOUT & INSTALLATION CLEARANCES 2 ZONE

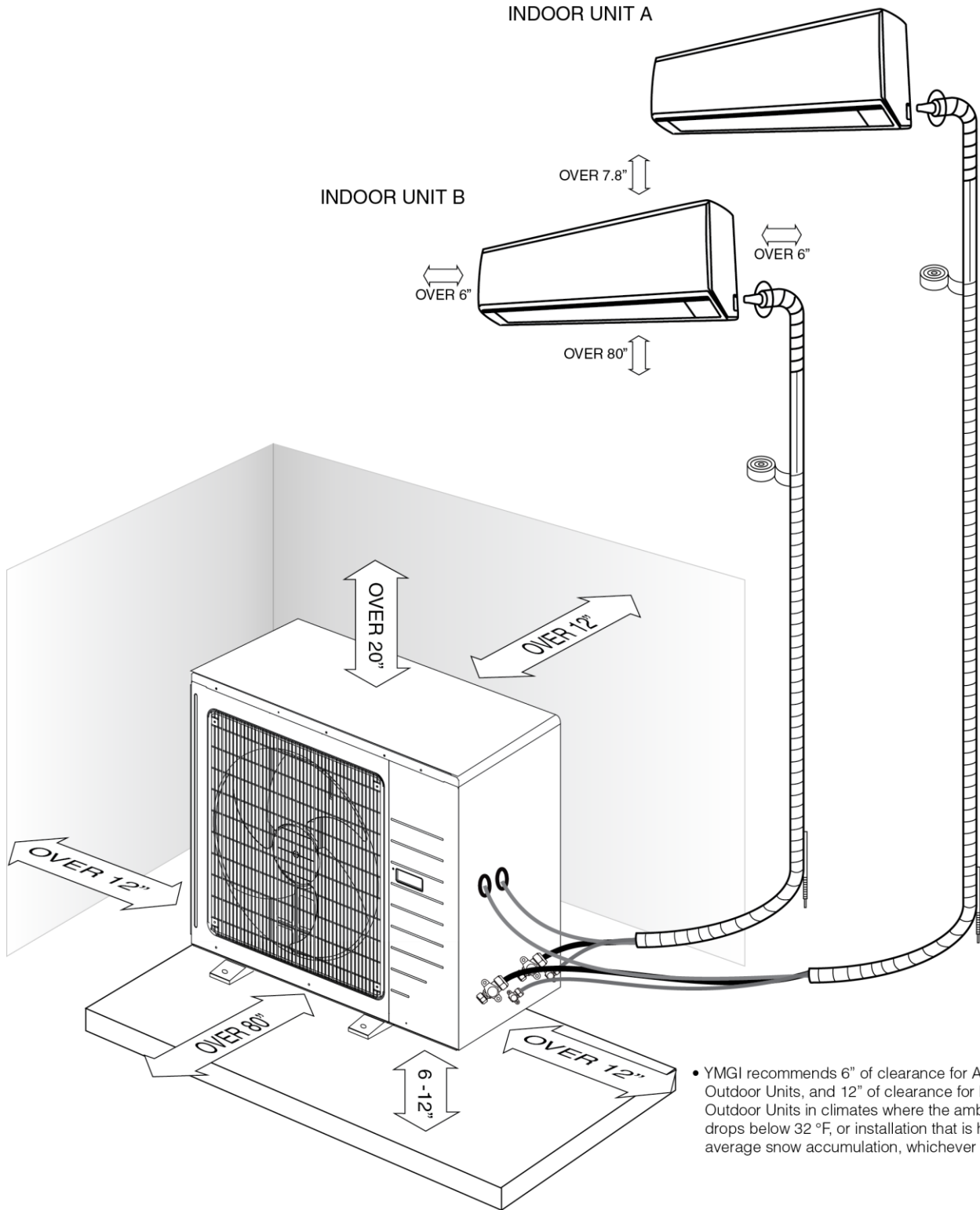

- YMG recommends 6" of clearance for AC only Outdoor Units, and 12" of clearance for Heat Pump Outdoor Units in climates where the ambient air temperature drops below 32 °F, or installation that is higher than average snow accumulation, whichever is greater.

# SYSTEM LAYOUT & INSTALLATION CLEARANCE 3 ZONE

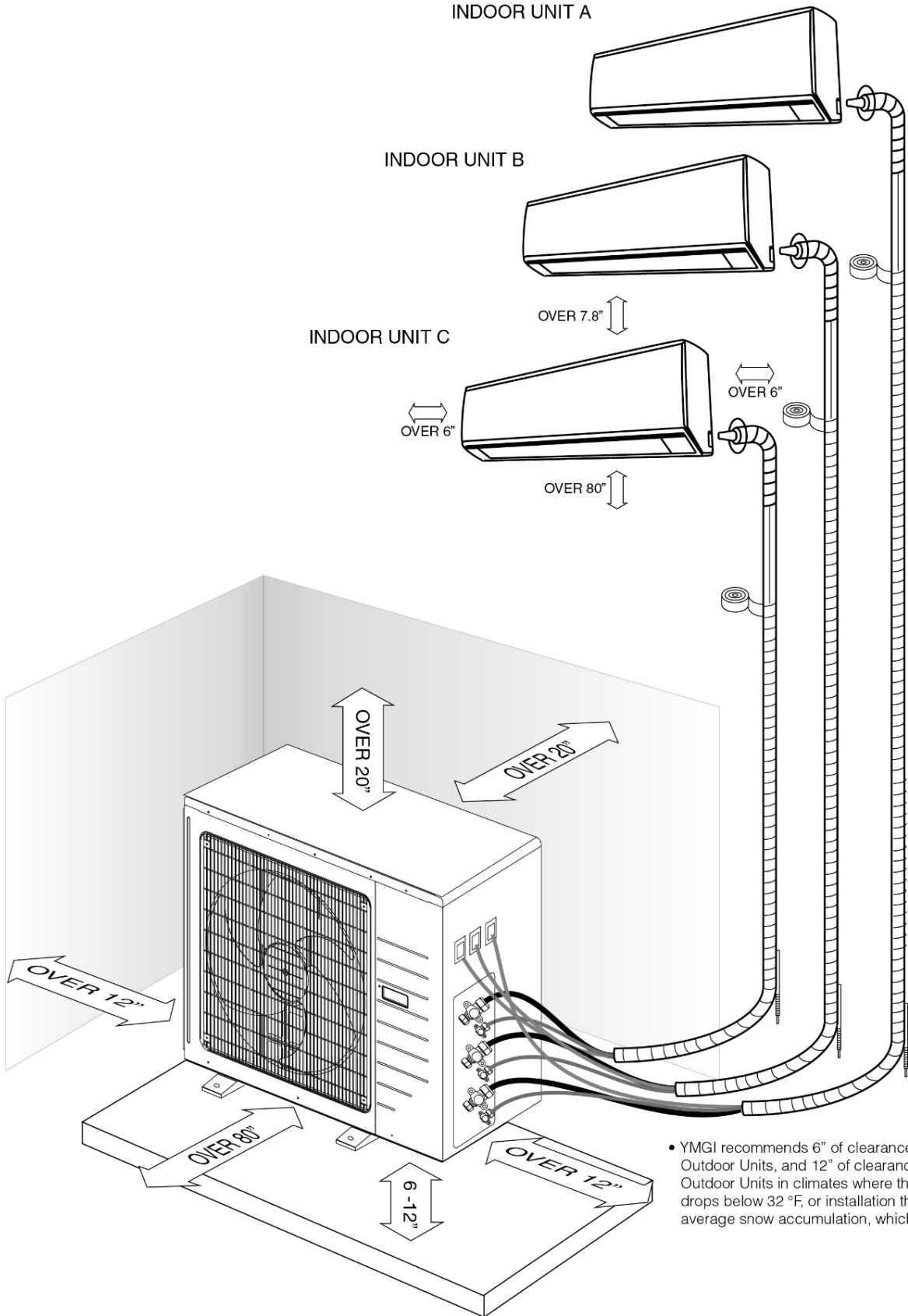

- YMG recommends 6" of clearance for AC only Outdoor Units, and 12" of clearance for Heat Pump Outdoor Units in climates where the ambient air temperature drops below 32 °F, or installation that is higher than average snow accumulation, whichever is greater.



## SYSTEM LAYOUT & INSTALLATION CLEARANCE 4 ZONE

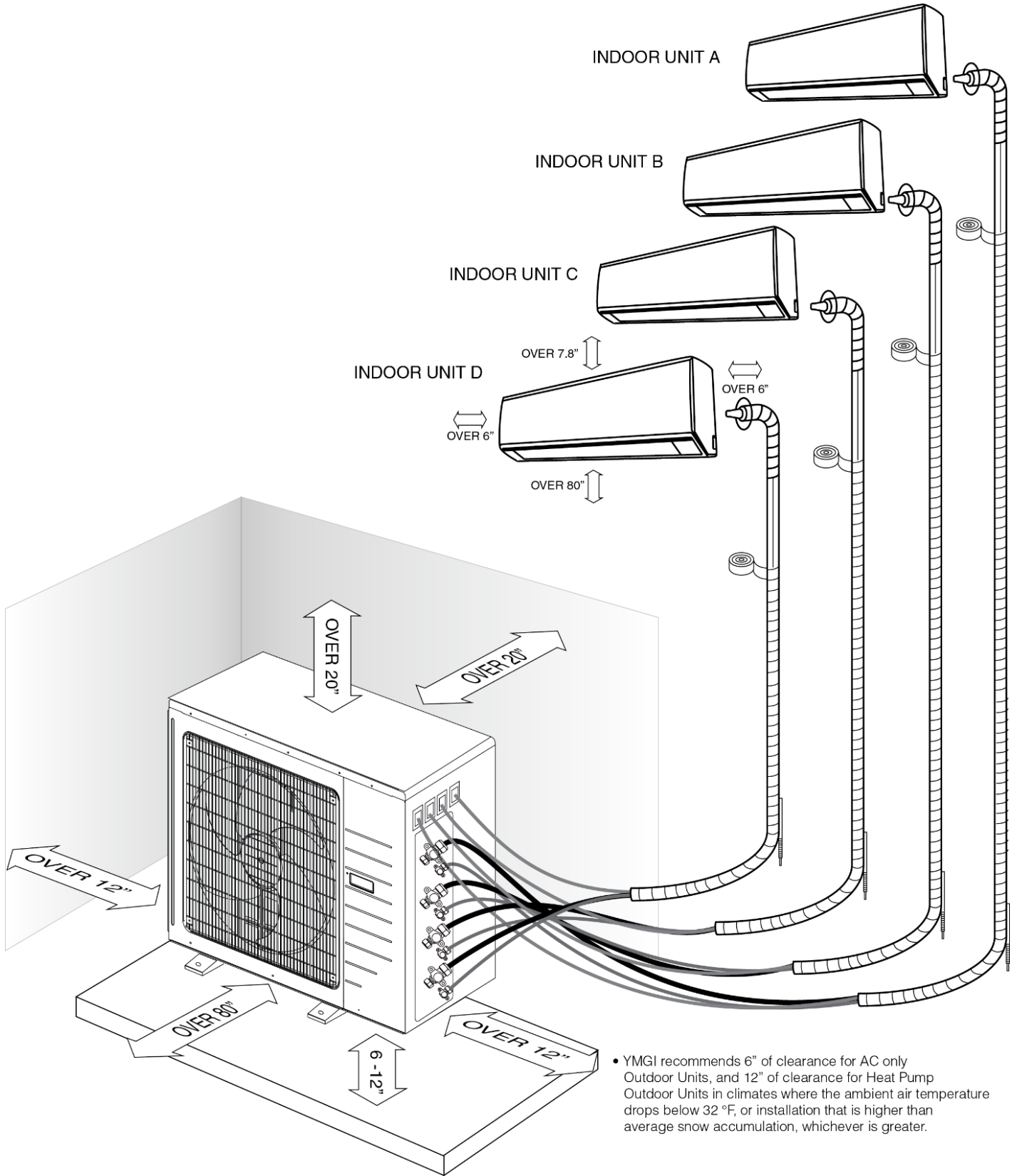

- YMG recommends 6" of clearance for AC only Outdoor Units, and 12" of clearance for Heat Pump Outdoor Units in climates where the ambient air temperature drops below 32 °F, or installation that is higher than average snow accumulation, whichever is greater.



# SYSTEM LAYOUT & INSTALLATION CLEARANCE 5 ZONE

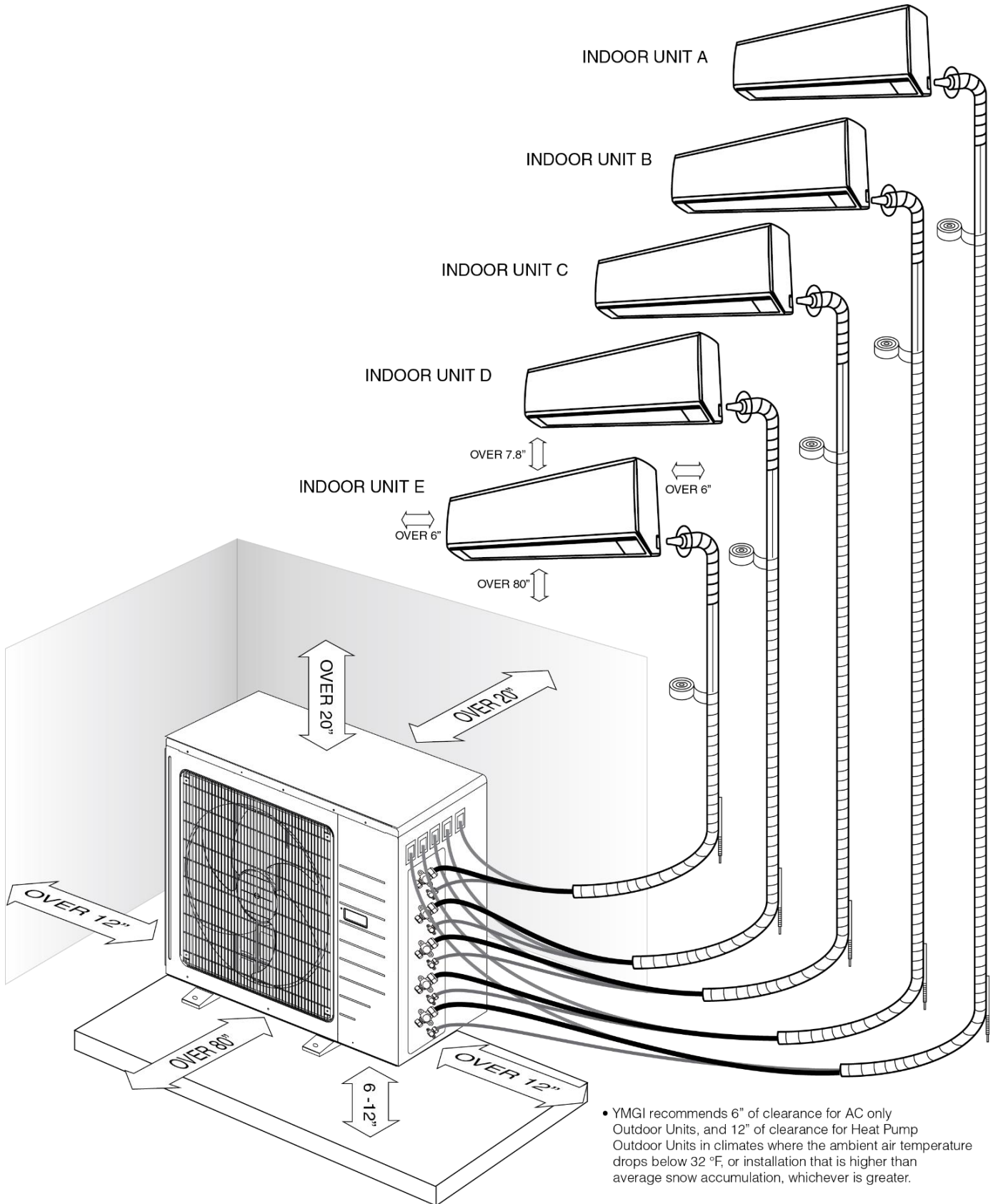

- YMG recommends 6" of clearance for AC only Outdoor Units, and 12" of clearance for Heat Pump Outdoor Units in climates where the ambient air temperature drops below 32 °F, or installation that is higher than average snow accumulation, whichever is greater.

# UNIT ENGINEERING SUBMITTALS-MECHANICAL

## OUTDOOR UNIT

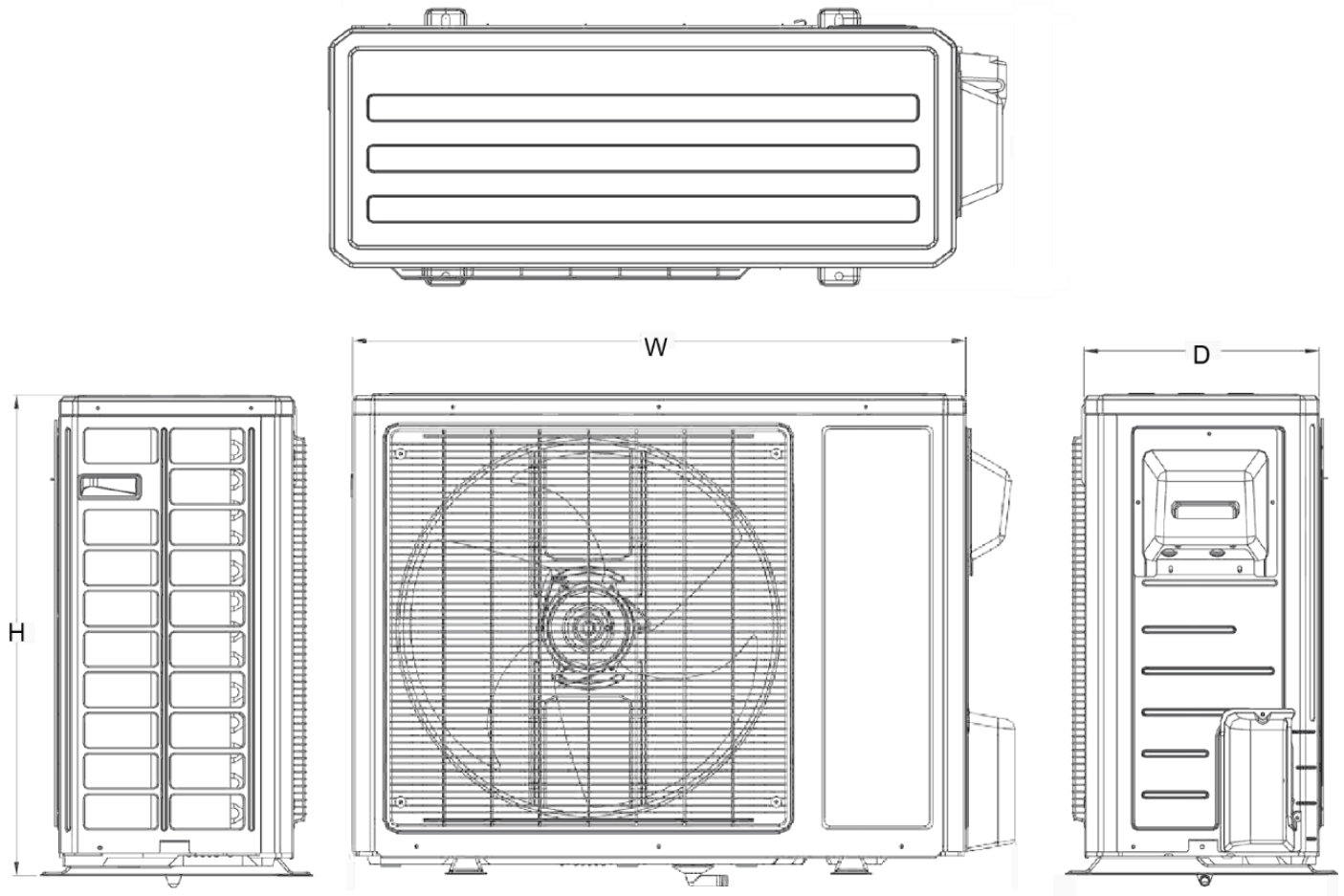

Model	Dimensions (In)			Weight (lbs.)	
	W	H	D	Net	Operation
30CH	37.63	27.56	15.59	114.6	124.5
36CH	38.58	31.13	16.8	153	164
42CH	38.58	31.13	16.8	154	169.76
48CH	42.8	43.43	17.32	198.4	216
60CH	42.8	43.43	17.32	198.4	216



### (59)4 ODU Specification Sheet

Outdoor Unit Models		WMMS-30CH-V2B(59)4 (1 to 2)	WMMS-36CH-V2B(59)4 (2 to 3)	WMMS-42CH-V2B(59)4 (2 to 4)	WMMS-48CH-V2B(59)4 (2 to 5)	WMMS-60CH-V2B(59)4 (2 to 5)
Power Supply		208/230 / 1 / 60	208/230 / 1 / 60	208/230 / 1 / 60	208/230 / 1 / 60	208/230 / 1 / 60
Cooling Capacity* (Btu/h)	Max. IDU Cap. Total 2	30,000 (2 Thermal Zones)	36,000 (2 Thermal Zones)	42,000 (2 Thermal Zones)	48,000 (2 Thermal Zones)	60,000 (2 Thermal Zones)
	Rated 1	18,000	24,000	28,400	34,000	39,000
	Min	7,000	7,500	8,200	8,900	8,870
Total Power Input in Cooling Mode* (W)	Max.	2800	3300	4500	4500	5100
	Rated	1440	2250	2600	2600	3950
	Min.	650	800	900	1000	1200
SEER		22.00	21.00	21.00	21.00	21.00
HSPF	Btu/h/ W	10.50	10.50	10.50	10.50	10.20
Heating Capacity* (Btu/h)	Max. IDU Cap. Total 2	32,000	38,000	50,000	59,000	64,000
	Rated 1	19,000	26,000	30,000	42,500	45,000
	Min.	7,000	7,500	8,200	8,900	8,870
Total Power Input in Heating Mode*	Max.	2400	3000	3500	3500	4800
	Rated	1750	2500	2920	2920	4400
	Min.	650	800	900	1000	1200
Liquid Valve Size	In	2 x 1/4"	3 x 1/4"	4 x 1/4"	5 x 1/4"	5 x 1/4"
Gas Valve Size	In	2 x 3/8"	3 x 3/8"	4 x 3/8"	5 x 3/8"	5 x 3/8"
Compressor Oil		RB68EP	RB68EP	FV50S	FV50S	FV50S
L.R.A.	A	27	45	45	45	55
Compressor RLA	A	10.82	15.82	13.9	15.6	17.8
Compressor Power Input	W	1440	2550	4150	4150	4150
MCA	A	16	23	20-All IDUs EW / 30-All IDUs EC or EU	23-All IDUs EW / 40-All IDUs EC or EU	24
Fuse or Circuit Breaker (HVAC Type)	A	25	30	30-All IDUs EW / 40-All IDUs EC or EU	35-All IDUs EW / 50-All IDUs EC or EU	40-All IDUs EW / 40-All IDUs EC or EU
Throttling Method		Electronic Expansion Valve	Electronic Expansion Valve	Electronic Expansion Valve	Electronic Expansion Valve	Electronic Expansion Valve
Starting Method		Transducer starting	Transducer starting	Transducer starting	Transducer starting	Transducer starting
Recommended Working Ambient Temp Ranges	°F	AC: 0 ~ 118 HP:-4 ~ 75	AC: 0 ~ 118 HP:-4 ~ 75	AC: 0 ~ 118 HP:-4 ~ 75	AC: 0 ~ 118 HP:-4 ~ 75	AC: 0 ~ 118 HP:-4 ~ 75
Condenser		Aluminum fin-copper tube	Aluminum fin-copper tube	Aluminum fin-copper tube	Aluminum fin-copper tube	Aluminum fin-copper tube
Output of Fan Motor	W	60	90	100	170	170
Fan Motor RLA	A	0.62	0.59	0.68	0.82	0.82





Outdoor Unit Models		WMMS-30CH-V2B(59)4 (1 to 2)	WMMS-36CH-V2B(59)4 (2 to 3)	WMMS-42CH-V2B(59)4 (2 to 4)	WMMS-48CH-V2B(59)4 (2 to 5)	WMMS-60CH-V2B(59) 4 (2 to 5)
Fan Motor Capacitor	uF	3	3.5	3.5	3.5	6
Fan Type-Piece		Axial-flow 1	Axial-flow 1	Axial-flow 1	Axial-flow 1	Axial-flow 1
Fan Diameter	In.	20.47	21.65	21.65	22.44	22.44
Defrosting Method		Auto Defrost	Auto Defrost	Auto Defrost	Auto Defrost	Auto Defrost
Climate Type		T1	T1	T1	T1	T1
Isolation		I	I	I	I	I
Moisture Protection		IP24	IP24	IP24	IP24	IP24
Max. Operating Pressure at High Side	PSI	550	550	550	550	550
Max. Operating Pressure at Low Side	PSI	240	240	240	240	240
Sound Pressure Level dB (H/L)	A	56	59	59	61	61
Sound Power Level dB (H/L)	A	63	69	69	71	71
Outdoor Unit Dimensions (W x H x D)	In.	38 x 27.6 x 13.4	38.6 x 31.1 x 13.4	38.4 x 31.1 x 14.6	42.8 x 43.43 x 17.32	42.8 x 43.43 x 17.32
Package Dimensions (W x H x D)	In.	40.5 x 29.53 x 18.03	42.64 x 33.63 x 19.21	42.64 x 33.66 x 19.21	45.59 x 48.62 x 19.41	45.59 x 48.62 x 19.41
Net /Gross Weight	LBs	114.6 / 124.5	153 / 164	154 / 169.76	198.4 / 216	198.4 / 216
R410A Refrigerant /Factory Pre-Charge for 25'	LBs	3.53	4.85	6.17	8.05	8.05
Maximum drive IDU NO.		2	3	4	5	5

**Notes:**

1. Performance rated for matched system at standard conditions-cooling ID 80/67°F, OD 95°F; heating ID 70/60°F, OD 47/43°F.  
Unit performance varies when weather changes from the standard one.
2. Select equipment capacity sizes per space load calculation schedule and cooling & heating hours. Not to over size or under size equipment.
3. Watch unit operation during extreme weather conditions in summer and winter. Wind baffle helps system cooling & heating performance in low ambient temperature ranges.
4. Heating capacities up to 85% @ 17°F ambient temperature, up to 60% @ -4°F.





**EXTENDED RATINGS-Various Indoor and Outdoor Temperatures  
WMMS-30CH-V2B(59)4  
COOLING PERFORMANCE**

DB WB	Indoor Ambient Temperature											
	70°F (21°C) 59°F (15°C)			75°F (24°C) 63°F (17°C)			80°F (27°C) 67°F (19°C)			90°F (32°C) 73°F (23°C)		
	TC (BtuH)	SC (BtuH)	Input Power (watts)	TC (BtuH)	SC (BtuH)	Input Power (watts)	TC (BtuH)	SC (BtuH)	Input Power (watts)	TC (BtuH)	SC (BtuH)	Input Power (watts)
-0.4°F (-18°C)	10,850	8,510	700	12,230	9,600	740	12,930	10,140	770	14,570	11,430	820
5°F (-15°C)	11,120	8,720	700	12,550	9,840	750	13,420	10,530	770	14,940	11,720	820
14°F (-10°C)	11,480	9,010	720	12,950	10,160	760	13,690	10,740	790	15,430	12,100	850
23°F (-5°C)	12,580	9,870	720	14,330	11,240	760	15,420	12,090	790	16,960	13,300	840
32°F (0°C)	13,226	10,375	719	15,064	11,814	763	15,489	12,143	789	17,829	13,989	841
41°F (5°C)	13,905	10,907	756	15,836	12,419	802	16,283	12,766	829	18,743	14,707	884
50°F (10°C)	14,484	11,361	788	16,496	12,937	835	16,961	13,298	864	19,524	15,319	921
59°F (15°C)	15,260	11,970	830	17,380	13,630	880	17,870	14,010	910	20,570	16,140	970
68°F (20°C)	17,281	13,553	1,221	18,361	14,398	1,260	19,621	15,389	1,337	22,501	17,650	1,430
77°F (25°C)	17,077	13,395	1,254	18,163	14,246	1,293	19,441	15,249	1,375	22,321	17,504	1,474
86°F (30°C)	16,235	12,733	1,403	17,317	13,584	1,447	18,901	14,824	1,535	21,631	16,963	1,645
95°F (35°C)	15,367	12,052	1,507	16,441	12,891	1,551	18,001	14,119	1,650	20,719	16,252	1,766
104°F (40°C)	14,623	11,469	1,557	15,691	12,307	1,606	17,533	13,754	1,705	19,975	15,662	1,826
113°F (45°C)	13,873	10,879	1,590	14,941	11,718	1,639	16,789	13,164	1,744	19,225	15,079	1,865
118°F (48°C)	13,501	10,587	1,606	14,401	11,292	1,656	16,201	12,709	1,760	18,541	14,544	1,881

**HEATING PERFORMANCE**

Outdoor	Indoor Ambient Temperature												
	DB	70°F (21°C) 59°F (15°C)				75°F (24°C) 63°F (17°C)				80°F (27°C) 67°F (19°C)			
	WB	TC (Btu/H)	SC (Btu/H)	Input Power (watts)	COP (W/W)	TC (Btu/H)	SC (Btu/H)	Input Power (watts)	COP (W/W)	TC (Btu/H)	SC (Btu/H)	Input Power (watts)	COP (W/W)
Outdoor Ambient Temperature (DB)	-5°F (-21°C)	<b>10,865</b>	<b>10,865</b>	<b>1,840</b>	<b>1.73</b>	<b>10,656</b>	<b>10,656</b>	<b>1,880</b>	<b>1.66</b>	<b>10,325</b>	<b>10,325</b>	<b>1,920</b>	<b>1.58</b>
	0°F (-18°C)	11,121	11,121	1,800	<b>1.81</b>	10,800	10,800	1,840	<b>1.72</b>	10,598	10,598	1,880	<b>1.65</b>
	5°F (-15°C)	11,428	11,428	1,751	<b>1.91</b>	11,099	11,099	1,791	<b>1.82</b>	10,891	10,891	1,831	<b>1.74</b>
	7°F (-14°C)	11,736	11,736	1,722	<b>2.00</b>	11,397	11,397	1,762	<b>1.90</b>	11,184	11,184	1,802	<b>1.82</b>
	17°F (-8°C)	12,597	12,597	1,663	<b>2.22</b>	12,229	12,229	1,703	<b>2.11</b>	11,997	11,997	1,743	<b>2.02</b>
	28°F (-2°C)	14,230	14,230	1,601	<b>2.60</b>	13,856	13,856	1,641	<b>2.47</b>	13,458	13,458	1,681	<b>2.35</b>
	38°F (3°C)	17,693	17,693	1,593	<b>3.26</b>	17,319	17,319	1,633	<b>3.11</b>	16,927	16,927	1,673	<b>2.97</b>
	47°F (8°C)	19,997	19,997	1,590	<b>3.69</b>	19,392	19,392	1,630	<b>3.49</b>	19,006	19,006	1,670	<b>3.34</b>
	57°F (14°C)	20,657	20,657	1,519	<b>3.99</b>	20,033	20,033	1,559	<b>3.77</b>	19,635	19,635	1,599	<b>3.60</b>
	68°F (20°C)	21,490	21,490	1,495	<b>4.21</b>	20,840	20,840	1,535	<b>3.98</b>	20,430	20,430	1,575	<b>3.80</b>
77°F (25°C)	21,990	21,990	1,461	<b>4.41</b>	21,330	21,330	1,501	<b>4.16</b>	20,900	20,900	1,541	<b>3.97</b>	

**LEGEND**

- DB --- Dry Bulb
- WB --- Wet Bulb
- TC --- Total Net Cooling Capacity (BtuH)
- SC --- Sensible Capacity (BtuH)
- Input Power---(Watts)

Specifications are subject to change without notice. Manufacturer reserves the right to discontinue or modify specifications or designs without notice or without incurring obligations. All rights reserved.





**EXTENDED RATINGS-Variou s Indoor and Outdoor Temperatures  
WMMS-36CH-V2B(59)4  
COOLING PERFORMANCE**

DB WB	Indoor Ambient Temperature											
	70°F (21°C) 59°F (15°C)			75°F (24°C) 63°F (17°C)			80°F (27°C) 67°F (19°C)			90°F (32°C) 73°F (23°C)		
	TC (Btu/H)	SC (Btu/H)	Input Power (watts)	TC (Btu/H)	SC (Btu/H)	Input Power (watts)	TC (Btu/H)	SC (Btu/H)	Input Power (watts)	TC (Btu/H)	SC (Btu/H)	Input Power (watts)
-0.4°F (-18°C)	14,670	11,510	1,180	16,550	12,980	1,250	17,500	13,720	1,300	19,720	15,460	1,390
5°F (-15°C)	15,050	11,800	1,180	16,970	13,320	1,260	18,160	14,240	1,300	20,220	15,860	1,390
14°F (-10°C)	16,590	13,010	1,200	17,710	14,680	1,270	19,780	15,510	1,320	22,290	17,480	1,410
23°F (-5°C)	18,170	14,260	1,200	20,700	16,240	1,270	22,270	17,470	1,310	24,500	19,220	1,400
32°F (0°C)	19,103	14,986	1,196	21,764	14,466	1,265	22,379	17,543	1,309	25,759	20,204	1,404
41°F (5°C)	20,083	15,754	1,257	22,880	15,208	1,330	23,527	18,442	1,376	27,080	21,240	1,476
50°F (10°C)	20,919	16,411	1,310	23,833	15,841	1,386	24,507	19,211	1,433	28,209	22,125	1,538
59°F (15°C)	22,040	17,290	1,380	25,110	16,690	1,460	25,820	20,240	1,510	29,720	23,310	1,620
68°F (20°C)	24,961	19,577	2,028	26,521	20,797	2,092	28,341	22,228	2,219	32,501	25,494	2,375
77°F (25°C)	24,666	19,349	2,082	26,235	20,578	2,146	28,081	22,026	2,283	32,241	25,283	2,448
86°F (30°C)	23,453	18,392	2,329	25,013	19,621	2,402	27,301	21,412	2,548	31,245	24,502	2,731
95°F (35°C)	22,196	17,409	2,503	23,748	18,620	2,576	26,001	20,394	2,740	29,927	23,475	2,932
104°F (40°C)	21,122	16,566	2,585	22,664	17,777	2,667	25,325	19,867	2,831	28,853	22,623	3,032
113°F (45°C)	20,038	15,714	2,640	21,581	16,926	2,722	24,250	19,015	2,895	27,769	21,781	3,096
118°F (48°C)	19,501	15,293	2,667	20,801	16,311	2,749	23,401	18,357	2,923	26,781	21,008	3,124

**HEATING PERFORMANCE**

Outdoor WB	DB	Indoor Ambient Temperature											
		70°F (21°C) 59°F (15°C)				75°F (24°C) 63°F (17°C)				80°F (27°C) 67°F (19°C)			
		TC (Btu/H)	SC (Btu/H)	Input Power (watts)	COP (W/W)	TC (Btu/H)	SC (Btu/H)	Input Power (watts)	COP (W/W)	TC (Btu/H)	SC (Btu/H)	Input Power (watts)	COP (W/W)
Outdoor Ambient Temperature (DB)	-5°F (-21°C)	16,563	16,563	2,470	<b>1.97</b>	16,045	16,045	2,500	<b>1.88</b>	15,625	2,530	1,624	<b>2.82</b>
	0°F (-18°C)	16,974	16,974	2,410	<b>2.06</b>	16,485	16,485	2,440	<b>1.98</b>	16,177	2,470	1,669	<b>2.84</b>
	5°F (-15°C)	17,442	17,442	2,335	<b>2.19</b>	16,939	16,939	2,365	<b>2.10</b>	16,622	2,395	1,706	<b>2.85</b>
	7°F (-14°C)	17,909	17,909	2,392	<b>2.19</b>	17,393	17,393	2,422	<b>2.10</b>	17,067	2,452	1,744	<b>2.87</b>
	17°F (-8°C)	19,224	19,224	2,358	<b>2.39</b>	18,662	18,662	2,388	<b>2.29</b>	18,308	2,418	1,819	<b>2.95</b>
	28°F (-2°C)	21,716	21,716	2,332	<b>2.73</b>	21,145	21,145	2,362	<b>2.62</b>	20,538	2,392	1,938	<b>3.11</b>
	38°F (3°C)	27,000	27,000	2,319	<b>3.41</b>	26,429	26,429	2,349	<b>3.30</b>	25,831	2,379	2,230	<b>3.39</b>
	47°F (8°C)	29,017	29,017	2,318	<b>3.67</b>	29,592	29,592	2,348	<b>3.69</b>	29,003	2,378	2,320	<b>3.66</b>
	57°F (14°C)	31,523	31,523	2,213	<b>4.18</b>	30,571	30,571	2,243	<b>4.00</b>	29,964	2,273	2,365	<b>3.71</b>
	68°F (20°C)	32,810	32,810	2,177	<b>4.42</b>	31,810	31,810	2,207	<b>4.22</b>	31,180	2,237	2,450	<b>3.73</b>
77°F (25°C)	33,570	33,570	2,142	<b>4.59</b>	32,550	32,550	2,172	<b>4.39</b>	31,900	2,202	2,510	<b>3.72</b>	

**LEGEND**

- DB --- Dry Bulb
- WB --- Wet Bulb
- TC --- Total Net Cooling Capacity (BtuH)
- SC --- Sensible Capacity (BtuH)
- Input Power---(Watts)

Specifications are subject to change without notice. Manufacturer reserves the right to discontinue or modify specifications or designs without notice or without incurring obligations. All rights reserved.





**EXTENDED RATINGS-Variou s Indoor and Outdoor Temperatures  
WMMS-42CH-V2B(59)4  
COOLING PERFORMANCE**

DB WB	Indoor Ambient Temperature											
	70°F (21°C) 59°F (15°C)			75°F (24°C) 63°F (17°C)			80°F (27°C) 67°F (19°C)			90°F (32°C) 73°F (23°C)		
	TC (Btu/H)	SC (Btu/H)	Input Power (watts)	TC (Btu/H)	SC (Btu/H)	Input Power (watts)	TC (Btu/H)	SC (Btu/H)	Input Power (watts)	TC (Btu/H)	SC (Btu/H)	Input Power (watts)
-0.4°F (-18°C)	17,230	13,510	1,050	19,430	15,240	1,110	20,540	16,110	1,150	23,150	18,150	1,230
5°F (-15°C)	17,670	13,860	1,050	19,930	15,630	1,120	21,320	16,720	1,150	23,730	18,620	1,230
14°F (-10°C)	18,500	14,510	1,060	20,870	16,370	1,120	22,060	17,300	1,160	24,860	19,490	1,240
23°F (-5°C)	20,270	15,900	1,060	23,090	18,110	1,120	24,840	19,490	1,150	27,330	21,430	1,230
32°F (0°C)	20,368	17,612	1,430	23,281	19,840	1,430	25,621	21,538	1,699	26,748	25,005	1,612
41°F (5°C)	21,413	18,515	1,503	24,474	20,857	1,503	26,935	22,643	1,786	28,119	26,288	1,695
50°F (10°C)	22,305	19,287	1,566	25,494	21,726	1,566	28,057	23,586	1,860	29,291	27,383	1,765
59°F (15°C)	23,500	20,320	1,650	26,860	22,890	1,650	29,560	24,850	1,960	30,860	28,850	1,860
68°F (20°C)	24,520	21,135	1,736	27,550	23,714	1,760	30,313	25,704	2,009	31,228	29,201	2,025
77°F (25°C)	28,631	23,264	2,108	31,071	25,502	2,111	33,852	27,389	2,365	37,373	28,573	2,402
86°F (30°C)	30,859	24,172	2,826	33,084	26,134	2,853	35,179	32,712	2,905	39,601	29,290	2,955
95°F (35°C)	28,914	23,131	3,099	31,218	25,298	3,121	33,654	26,154	3,206	37,012	28,522	3,267
104°F (40°C)	22,851	20,906	2,566	24,550	22,872	2,583	26,052	24,462	2,773	28,321	25,171	2,668
113°F (45°C)	17,839	17,658	2,172	19,214	19,057	2,207	25,738	25,110	2,835	21,800	21,387	2,244
118°F (48°C)	13,700	13,628	1,708	15,030	14,908	1,762	16,634	16,382	1,896	17,770	17,433	1,867

**HEATING PERFORMANCE**

Outdoor	DB WB	Indoor Ambient Temperature											
		70°F (21°C) 59°F (15°C)				75°F (24°C) 63°F (17°C)				80°F (27°C) 67°F (19°C)			
		TC (Btu/H)	SC (Btu/H)	Input Power (watts)	COP (W/W)	TC (Btu/H)	SC (Btu/H)	Input Power (watts)	COP (W/W)	TC (Btu/H)	SC (Btu/H)	Input Power (watts)	COP (W/W)
Outdoor Ambient Temperature (DB)	-5°F (-21°C)	18,126	18,126	2,870	<b>1.85</b>	17,756	17,756	2,900	<b>1.79</b>	17,059	17,059	2,930	<b>1.71</b>
	0°F (-18°C)	18,500	18,500	2,810	<b>1.93</b>	17,960	17,960	2,840	<b>1.85</b>	17,630	17,630	2,870	<b>1.80</b>
	5°F (-15°C)	19,510	19,510	2,730	<b>2.09</b>	18,950	18,950	2,760	<b>2.01</b>	18,590	18,590	2,790	<b>1.95</b>
	7°F (-14°C)	20,010	20,010	2,720	<b>2.16</b>	19,050	19,050	2,750	<b>2.03</b>	19,360	19,360	2,780	<b>2.04</b>
	17°F (-8°C)	20,940	20,940	2,700	<b>2.27</b>	20,330	20,330	2,730	<b>2.18</b>	19,950	19,950	2,760	<b>2.12</b>
	28°F (-2°C)	23,660	23,660	2,680	<b>2.59</b>	23,040	23,040	2,710	<b>2.49</b>	22,380	22,380	2,740	<b>2.39</b>
	38°F (3°C)	29,420	29,420	2,670	<b>3.23</b>	28,800	28,800	2,700	<b>3.13</b>	28,140	28,140	2,730	<b>3.02</b>
	47°F (8°C)	33,250	33,250	2,650	<b>3.68</b>	32,240	32,240	2,680	<b>3.53</b>	31,600	31,600	2,710	<b>3.42</b>
	57°F (14°C)	34,350	34,350	2,520	<b>4.00</b>	33,310	33,310	2,550	<b>3.83</b>	32,650	32,650	2,580	<b>3.71</b>
	68°F (20°C)	35,750	35,750	2,450	<b>4.28</b>	34,660	34,660	2,480	<b>4.10</b>	33,970	33,970	2,510	<b>3.97</b>
77°F (25°C)	36,580	36,580	2,420	<b>4.43</b>	35,470	35,470	2,450	<b>4.24</b>	34,760	34,760	2,480	<b>4.11</b>	

**LEGEND**

- DB --- Dry Bulb
- WB --- Wet Bulb
- TC --- Total Net Cooling Capacity (BtuH)
- SC --- Sensible Capacity (BtuH)
- Input Power---(Watts)

Specifications are subject to change without notice. Manufacturer reserves the right to discontinue or modify specifications or designs without notice or without incurring obligations. All rights reserved.







**EXTENDED RATINGS-Various Indoor and Outdoor Temperatures  
WMMS-48CH-V2B(59)4  
COOLING PERFORMANCE**

DB WB	Indoor Ambient Temperature											
	70°F (21°C) 59°F (15°C)			75°F (24°C) 63°F (17°C)			80°F (27°C) 67°F (19°C)			90°F (32°C) 73°F (23°C)		
	TC (Btu/H)	SC (Btu/H)	Input Power (watts)	TC (Btu/H)	SC (Btu/H)	Input Power (watts)	TC (Btu/H)	SC (Btu/H)	Input Power (watts)	TC (Btu/H)	SC (Btu/H)	Input Power (watts)
-0.4°F (-18°C)	20,420	16,010	1,200	23,030	18,060	1,270	24,152	19,090	1,320	27,430	21,510	1,410
5°F (-15°C)	20,940	16,420	1,200	23,620	18,530	1,280	24,995	19,820	1,320	28,130	22,030	1,410
14°F (-10°C)	21,690	17,010	1,220	24,470	19,190	1,300	25,908	20,280	1,340	29,150	22,860	1,440
23°F (-5°C)	23,770	18,640	1,220	27,080	21,240	1,300	26,896	22,840	1,330	32,040	25,130	1,430
32°F (0°C)	24,979	19,588	1,222	28,455	22,319	1,291	29,178	22,943	1,335	33,681	25,057	1,395
41°F (5°C)	26,260	20,593	1,285	29,914	23,463	1,358	33,822	24,119	1,403	35,409	26,342	1,467
50°F (10°C)	27,355	21,451	1,338	31,161	24,441	1,414	37,125	25,124	1,462	36,884	27,440	1,528
59°F (15°C)	28,820	22,600	1,410	32,830	25,750	1,490	36,785	26,470	1,540	38,860	28,910	1,610
68°F (20°C)	32,620	29,556	2,010	33,422	30,044	1,995	36,444	31,733	2,010	41,526	33,695	2,025
77°F (25°C)	35,145	30,300	2,450	39,240	31,409	2,435	35,763	32,791	2,440	45,040	34,872	2,430
86°F (30°C)	35,486	30,368	3,120	38,438	32,364	3,125	35,082	33,012	3,160	45,211	34,650	3,185
95°F (35°C)	32,176	28,781	3,300	35,827	31,255	3,400	34,060	31,921	3,335	41,014	34,275	3,405
104°F (40°C)	27,451	26,444	3,075	30,095	28,543	3,085	33,617	29,856	3,115	35,452	32,671	3,145
113°F (45°C)	23,544	23,203	2,765	25,642	24,926	2,790	33,174	25,779	2,800	29,686	28,833	2,825
118°F (48°C)	16,382	16,232	1,856	17,504	17,242	1,911	32,471	18,354	1,986	20,186	19,923	2,023

**HEATING PERFORMANCE**

Outdoor	DB WB	Indoor Ambient Temperature											
		70°F (21°C) 59°F (15°C)				75°F (24°C) 63°F (17°C)				80°F (27°C) 67°F (19°C)			
		TC (Btu/H)	SC (Btu/H)	Input Power (watts)	COP (W/W)	TC (Btu/H)	SC (Btu/H)	Input Power (watts)	COP (W/W)	TC (Btu/H)	SC (Btu/H)	Input Power (watts)	COP (W/W)
Outdoor Ambient Temperature (DB)	-5°F (-21°C)	21,908	21,908	3,732	<b>1.72</b>	21,749	21,749	3,747	<b>1.70</b>	21,350	21,350	3,777	<b>1.66</b>
	0°F (-18°C)	23,744	23,744	3,736	<b>1.86</b>	23,571	23,571	3,751	<b>1.84</b>	23,119	23,119	3,781	<b>1.79</b>
	5°F (-15°C)	25,047	25,047	3,717	<b>1.97</b>	24,861	24,861	3,732	<b>1.95</b>	24,396	24,396	3,762	<b>1.90</b>
	7°F (-14°C)	26,085	26,085	3,672	<b>2.08</b>	25,899	25,899	3,687	<b>2.06</b>	25,407	25,407	3,717	<b>2.00</b>
	17°F (-8°C)	26,870	26,870	3,524	<b>2.23</b>	26,684	26,684	3,539	<b>2.21</b>	26,165	26,165	3,569	<b>2.15</b>
	28°F (-2°C)	30,142	30,142	3,458	<b>2.55</b>	30,302	30,302	3,473	<b>2.56</b>	29,783	29,783	3,503	<b>2.49</b>
	38°F (3°C)	37,910	37,910	3,415	<b>3.25</b>	38,070	38,070	3,430	<b>3.25</b>	37,538	37,538	3,460	<b>3.18</b>
	47°F (8°C)	42,566	42,566	3,409	<b>3.66</b>	42,247	42,247	3,424	<b>3.62</b>	41,395	41,395	3,454	<b>3.51</b>
	57°F (14°C)	43,976	43,976	3,340	<b>3.86</b>	43,630	43,630	3,355	<b>3.81</b>	42,752	42,752	3,385	<b>3.70</b>
	68°F (20°C)	45,758	45,758	3,315	<b>4.05</b>	45,413	45,413	3,330	<b>4.00</b>	44,495	44,495	3,360	<b>3.88</b>
77°F (25°C)	46,823	46,823	3,350	<b>4.10</b>	46,463	46,463	3,365	<b>4.05</b>	45,532	45,532	3,395	<b>3.93</b>	

**LEGEND**

- DB --- Dry Bulb
- WB --- Wet Bulb
- TC --- Total Net Cooling Capacity (BtuH)
- SC --- Sensible Capacity (BtuH)
- Input Power---(Watts)

Specifications are subject to change without notice. Manufacturer reserves the right to discontinue or modify specifications or designs without notice or without incurring obligations. All rights reserved.





**EXTENDED RATINGS-Various Indoor and Outdoor Temperatures  
WMMS-60CH-V2B(59)4  
COOLING PERFORMANCE**

DB WB	Indoor Ambient Temperature											
	70°F (21°C) 59°F (15°C)			75°F (24°C) 63°F (17°C)			80°F (27°C) 67°F (19°C)			90°F (32°C) 73°F (23°C)		
	TC (Btu/H)	SC (Btu/H)	Input Power (watts)	TC (Btu/H)	SC (Btu/H)	Input Power (watts)	TC (Btu/H)	SC (Btu/H)	Input Power (watts)	TC (Btu/H)	SC (Btu/H)	Input Power (watts)
-0.4°F (-18°C)	23,610	18,510	1,620	26,630	20,890	1,710	28,140	22,070	1,780	31,720	24,870	1,900
5°F (-15°C)	24,210	18,990	1,620	27,310	21,420	1,730	29,220	22,910	1,780	32,520	25,510	1,900
14°F (-10°C)	24,880	19,510	1,630	28,070	22,020	1,730	29,670	23,270	1,800	33,440	26,220	1,920
23°F (-5°C)	27,260	21,380	1,630	31,060	24,360	1,730	33,410	26,200	1,780	36,750	28,820	1,910
32°F (0°C)	28,654	22,475	1,629	32,641	25,603	1,725	32,329	26,323	1,785	38,639	29,478	1,915
41°F (5°C)	30,124	23,627	1,713	34,315	26,916	1,813	33,987	27,673	1,877	40,621	30,989	2,014
50°F (10°C)	31,379	24,612	1,784	35,745	28,038	1,889	35,403	28,826	1,955	42,313	32,281	2,098
59°F (15°C)	33,060	25,930	1,880	37,660	29,540	1,990	37,300	30,370	2,060	44,580	34,010	2,210
68°F (20°C)	33,012	29,754	1,980	33,575	29,396	1,990	37,499	32,125	2,000	44,870	34,138	2,210
77°F (25°C)	35,213	29,174	2,480	37,977	30,965	2,685	41,389	33,541	2,820	47,804	34,463	2,515
86°F (30°C)	36,510	29,037	3,650	38,540	31,238	3,555	43,334	34,121	3,600	48,572	35,333	3,280
95°F (35°C)	33,780	29,344	3,635	36,612	31,801	3,485	40,809	33,780	3,590	41,406	33,814	3,555
104°F (40°C)	29,481	27,297	3,600	33,831	30,931	3,645	34,974	32,586	3,670	37,875	32,722	3,735
113°F (45°C)	23,203	22,486	2,750	25,779	24,567	2,775	28,662	26,683	2,800	29,856	28,031	2,830
118°F (48°C)	16,795	16,508	1,988	18,255	17,668	2,101	19,381	18,528	2,158	20,531	19,749	2,204

**HEATING PERFORMANCE**

Outdoor WB	DB	Indoor Ambient Temperature											
		70°F (21°C) 59°F (15°C)				75°F (24°C) 63°F (17°C)				80°F (27°C) 67°F (19°C)			
		TC (Btu/H)	SC (Btu/H)	Input Power (watts)	COP (W/W)	TC (Btu/H)	SC (Btu/H)	Input Power (watts)	COP (W/W)	TC (Btu/H)	SC (Btu/H)	Input Power (watts)	COP (W/W)
Outdoor Ambient Temperature (DB)	-5°F (-21°C)	24,180	24,180	3,820	<b>1.86</b>	23,565	23,565	3,850	<b>1.79</b>	23,016	23,016	3,900	<b>1.73</b>
	0°F (-18°C)	24,880	24,880	3,740	<b>1.95</b>	24,160	24,160	3,770	<b>1.88</b>	23,710	23,710	3,820	<b>1.82</b>
	5°F (-15°C)	26,240	26,240	3,630	<b>2.12</b>	25,490	25,490	3,660	<b>2.04</b>	25,010	25,010	3,710	<b>1.98</b>
	7°F (-14°C)	27,350	27,350	3,570	<b>2.25</b>	26,550	26,550	3,600	<b>2.16</b>	26,040	26,040	3,650	<b>2.09</b>
	17°F (-8°C)	28,170	28,170	3,440	<b>2.40</b>	27,350	27,350	3,470	<b>2.31</b>	26,830	26,830	3,520	<b>2.23</b>
	28°F (-2°C)	31,820	31,820	3,400	<b>2.74</b>	30,990	30,990	3,430	<b>2.65</b>	30,100	30,100	3,480	<b>2.54</b>
	38°F (3°C)	39,560	39,560	3,380	<b>3.43</b>	38,730	38,730	3,410	<b>3.33</b>	37,850	37,850	3,460	<b>3.21</b>
	47°F (8°C)	43,720	43,720	3,470	<b>3.69</b>	43,360	43,360	3,500	<b>3.63</b>	42,500	42,500	3,550	<b>3.51</b>
	57°F (14°C)	46,190	46,190	3,280	<b>4.13</b>	44,800	44,800	3,310	<b>3.97</b>	43,910	43,910	3,360	<b>3.83</b>
	68°F (20°C)	48,080	48,080	3,180	<b>4.43</b>	46,620	46,620	3,210	<b>4.26</b>	45,690	45,690	3,260	<b>4.11</b>
	77°F (25°C)	49,190	49,190	3,140	<b>4.59</b>	47,710	47,710	3,170	<b>4.41</b>	46,750	46,750	3,220	<b>4.26</b>

**LEGEND**

- DB --- Dry Bulb
- WB --- Wet Bulb
- TC --- Total Net Cooling Capacity (BtuH)
- SC --- Sensible Capacity (BtuH)
- Input Power---(Watts)

Specifications are subject to change without notice. Manufacturer reserves the right to discontinue or modify specifications or designs without notice or without incurring obligations. All rights reserved.



## RECOMMENDED TOOLS FOR INSTALLATION

### 1. Mounting Indoor & Outdoor Units and Running Piping/Wiring

- Ruler
- Stud-Finder
- Dry-Wall Saw
- Electric Drill
- 3" Hole Saw
- Drill Extension
- Hammer Drill and Bit
- Measuring Tape
- Level
- Flash Light
- Screw Driver (Phillips and Flat)
- Hammer
- Knife
- Scissors
- Goggled Glasses
- Mask
- Gloves
- Ladder



### 2. Refrigeration Related Work

- Flat Surface Wrench (Two)
- Flare-Nut Tool Set
- Hex Head Key Set
- Torch for AC Application
- Heat Absorption Flux
- Nitrogen
- Soap Bubble
- Vacuum Pump
- Helium Leakage Check
- Manifold



### 3. Electrical Related Installation

- Wire Cutter
- Wire Stripper
- Sharp Plier
- Cable Ties
- Black Tape for Electrical Use
- Electrical Meter

### 4. Trial Running Units and Inspection

- Clamp Meter
- Manifold
- Infrared Thermometer

## INSTALLATION LOCATION SELECTION

### **⚠ CAUTION**

**All Units Shall Be Installed by Licensed Contractors or Technicians.**

**Read Manuals before Installation.**

- The location and structure should also be convenient for both installation and service.
- The location should NOT be where discharge air and noise could annoy a neighbor.
- The location should NOT be where drain may cause any damage to property or annoy a neighbor.
- The location should NOT be where brazing work may cause fire or smoke to the surrounding materials.
- The location should NOT be near flammable gases.
- The location should NOT be in or close to corrosive gases.
- The location should NOT be where children can access.

### **⚠ CAUTION**

#### **CAUTION & SUGGESTIONS TO FOLLOW PRIOR TO INSTALLATION**

- Check the unit for damage and missing parts or accessories. If there is damage is found or parts are found missing, call the distributor right away.
- Spin fan wheels or blades to check if they can rotate freely. If the fan wheel scratches the housing, call the distributor right away and do not proceed with the installation until it is fixed.
- Check the unit to make sure no foreign materials have been left inside the unit.
- Check to be sure you have all the additional parts and accessories that are required for the installation and those provided with the unit.
- It is strongly recommended to only use YMGI supplied or approved parts and accessories.
- Be sure a properly sized circuit breaker is installed for the electric power supplying the units.
- Pre-build the support platform on the ground or bracket for the wall before or during construction and before installation.
- Read installation instructions for all units thoroughly.
- Ask rep./distributor/YMGI Group anything you are not sure about.
- Get your tools and parts ready and start the installation.

#### **BASIC REQUIREMENTS FOR THE INSTALLATION LOCATION**

- Choose a location where there are no strong heat sources, vapors, flammable gas or volatile objects.
- Choose a location where there are no high-frequency waves being generated by radio equipment, welders and medical equipment.
- Choose a location where there are not a lot of salinities, such as coastal areas.
- Choose a location where there is no oil (machine oil) contained in the air.
- Choose a location where there is no Sulfur gas present, such as areas close to hot springs.
- Choose a location where there is no other special circumstance.

## HANDLING

- After having removed the packaging, check that the contents are intact and complete.
- The outdoor unit must always be kept upright.
- Handling must be done by suitably equipped qualified technician using equipment that is suitable for the weight of the appliance.

## INSTALLING OUTDOOR UNIT

- Use bolts to secure the unit to a flat, solid floor.
- When mounting the unit on a wall or the roof, make sure the support is firmly secured so that it cannot move in the event of intense vibrations or a strong wind.

- \* Do not install the outdoor unit in pits or air vents.
- \* Do not install the outdoor unit where it is exposed to direct sunlight.

## INSTALLING THE PIPES

- Use suitable connecting pipes and equipment for the refrigerant R410A.
- The refrigerant pipes must not exceed the maximum lengths given in the technical data table.
- Connect all the refrigerant pipes and joints.
- Tighten the connections using two wrenches working in opposite directions.

### Install the drain fitting and the drain hose (for heat pump models only)

Condensation is produced and flows from the outdoor unit when the appliance is operated in the heating mode. Install a drain fitting and a drain hose to channel the any condensate water. Install the drain fitting and rubber washer on the outdoor unit chassis and connect a drain hose to it as shown in the figure.

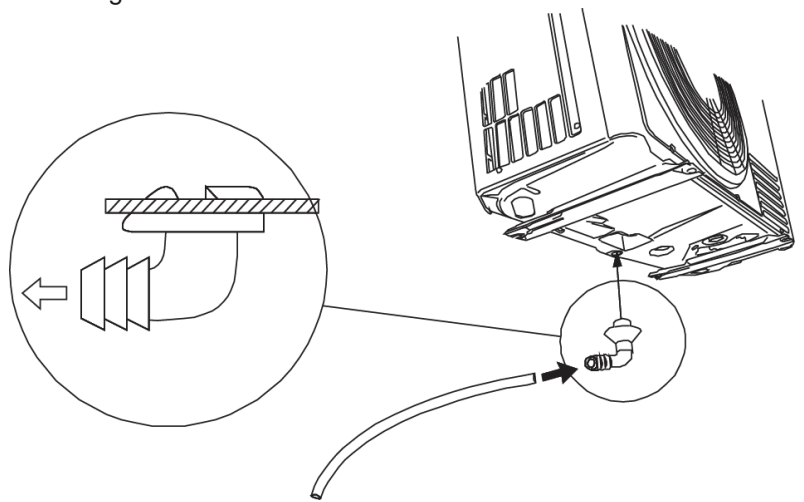

## ELEVATING OUTDOOR UNIT

Strongly suggest to install the outdoor unit above the ground either on a raised platform or brackets as shown below.

Heat pump units must be elevated above ground level due to condensate that must be drained out of the drain pan of the condensing unit. If the condensate cannot drain properly, it may accumulate and result in an ice buildup that can cause damage to the condensing unit.

We suggest using YMG mounting brackets and condensate drainage fitting accessories.

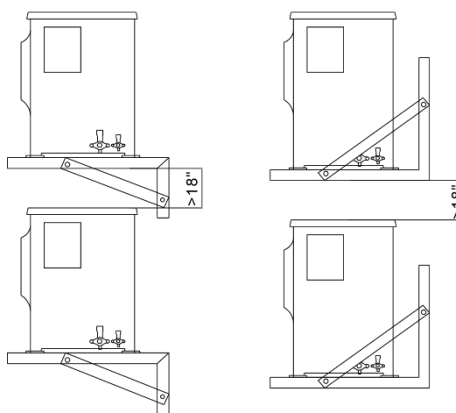



## CONNECT REFRIGERANT PIPES BETWEEN THE INDOOR AND OUTDOOR UNITS

First, connect the copper tubes at indoor unit. Bend the pipes appropriately, using pipe bending tools. Do NOT hand bend pipe, as this could create a kink in the line. Extra length is required for future servicing.

### REFRIGERANT PIPES

For a distance other than 25' between indoor and horizontal venting condensing units, refer to the following table for copper sizes.

#### Refrigerant Valve and Pipe Size/Length

Btu/h	Valve Size	Sample 09k IDU Line Sizes at Different Lengths*	
	Liquid, Gas	15 – 30 ft.	31 – 75 ft.
30CH	(1/4", 3/8") x 2	1/4", 3/8"	1/4", 1/2"
36CH	(1/4", 3/8") x 3	1/4", 3/8"	1/4", 1/2"
42CH	(1/4", 3/8") x 4	1/4", 3/8"	1/4", 1/2"
48CH	(1/4", 3/8") x 5	1/4", 3/8"	1/4", 1/2"
60CH	(1/4", 3/8") x 5	1/4", 3/8"	1/4", 1/2"

**Note:** Higher Btu/h Indoor Units may require larger diameter refrigerant lines. Please consult your IDU installation manual for recommended refrigerant line size.

### Running Interconnecting Refrigerant Lines:

Use clean refrigeration grade copper pipe only. Keep the copper lines from kinking and transmitting any noise to walls, cabinets, etc. Pipe length not to exceed 150 feet, elevation not to exceed 35 feet. Insulate both the liquid and gas copper lines with at least 3/8-inch-thick insulation tubes. Band, tape and secure the refrigerant lines. Support copper lines at a proper distance apart to keep the tubes from sagging.

### CUTTING REFRIGERANT PIPE

Make sure where the pipe is to be cut is straight and smooth. Engage the cutting blade. The cutting blade must be straight and perpendicular to the pipe surface. Don't cut too fast or apply too much pressure. Turn and tighten the tube cutter slowly. Remove residual and de-bur the cut edge. The cut edge should be smooth and clean.

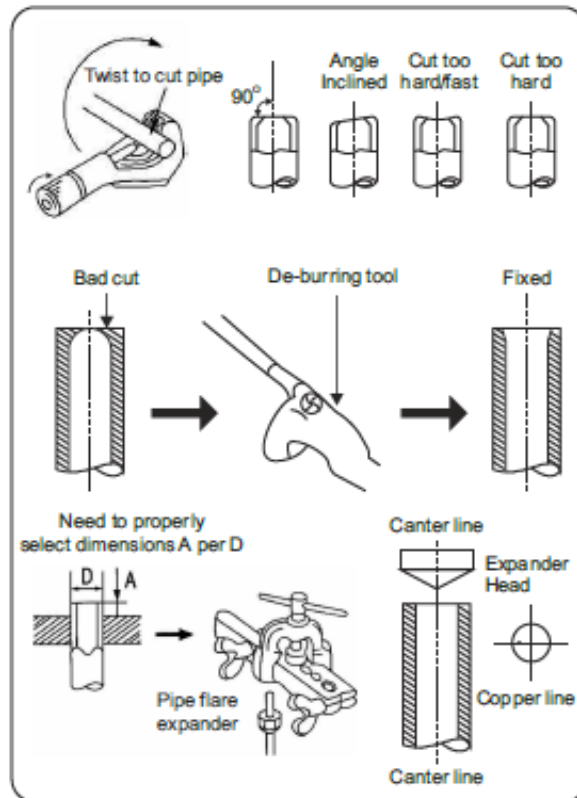

### Connect Copper Pipes-Flare/Nut Connection at both Indoor and Outdoor Units

Proper torque shall be applied to create a good connection at the female nut, flare and male nut, as recommended in the following table. Too much torque may damage and break the flare/nut seal. Too little torque may not ensure a good seal. ALWAYS use a pair of wrenches when tightening (as shown in the illustration below).

#### Refrigerant Pipe Flare/Nut Connection Tightening Torque

Flare Nut	Tightening Torque
1/4" – 3/8"	25 ft. lbs. (350 kg-cm)
1/4" – 1/2"	40 ft. lbs. (560 kg-cm)
1/2" – 3/4"	60 ft. lbs. (840 kg-cm)
7/8" – 1 1/8"	110 ft. lbs. (1540 kg-cm)

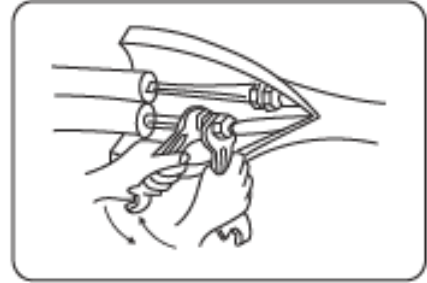

### Connect Copper Pipes-Sweat Connection

In this case, wrap a wet rag around the pipe to protect the valves or other components from being overheated. When using flux, rub the tube surface using steel wool to any oxidation then clean and dry to protect the system from any possible contamination.

### CONNECT REFRIGERANT PIPES BETWEEN THE INDOOR AND OUTDOOR UNITS

#### Seal Copper Line Set/Wire and Cable/Drain Hose Line Combination

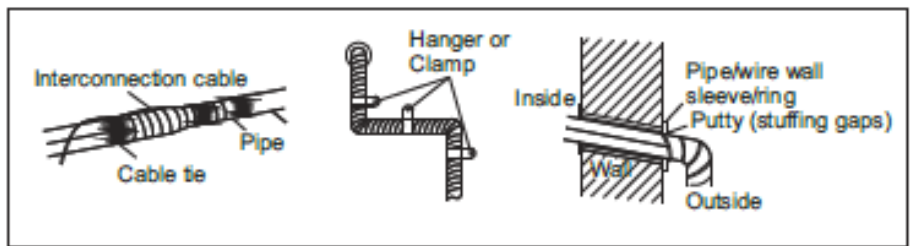
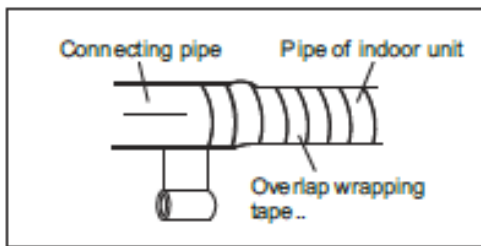
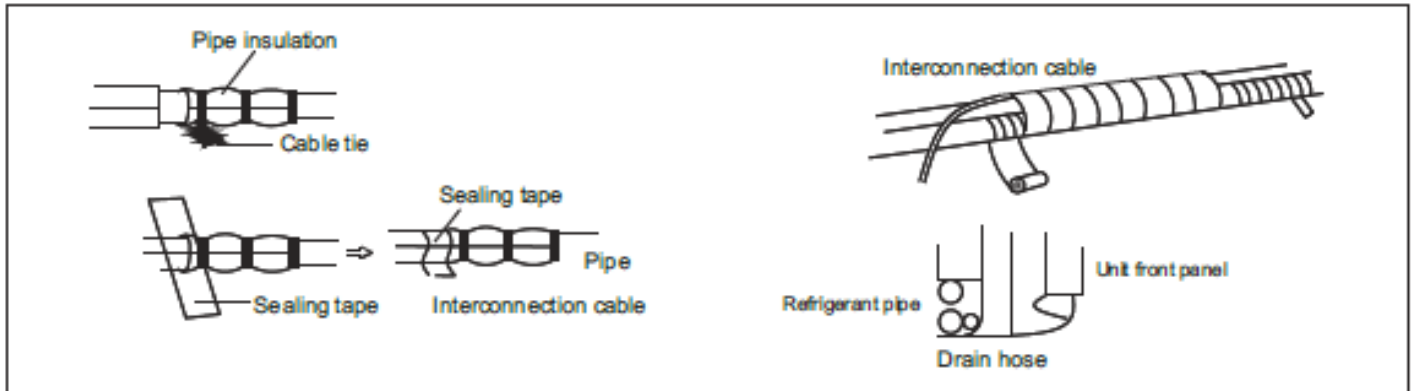

- Run cables along with the refrigerating copper line sets and secure them with tape, 6 feet apart.
- Wrap tape tight (cover a third of the width of the wrapping tape applied early) to ensure a good seal.
- Tape and seal the end of the wrapping tape.
- Shape the pipe combination gently, without causing kinking, sharp bends, or other damage to it.
- Fix the pipe combination securely on the external wall with proper clamps, 6 feet apart.
- Fill the gap between the wall hole and wall sleeve with putty to keep rain or dust entering inside.



## PIPING GUIDE

Set the packed pipes in a vertical position and then unwind them slowly.			Do not unwind only one end of the coiled pipes.
Use pulley or a bending tool to ensure a safe bending radius.			Do not make any sharp or small radius bends.
May also use rolling wheel to reduce internal pipe tension and avoid possible deformation.			Do not bend long sections of pipe without using bending tools.
Use an elbow tool for consistent bending radius.			Do not make bends that are less than 90 degrees.
Maintain the minimum bending radius.			Do not bend shot pipes.

## HEIGHT LIMITS OF INDOOR AND OUTDOOR UNITS

- The indoor unit, or the outdoor unit can be higher, but the height difference must comply with the stated technical requirements.
- Reduce bends in the piping as much as possible, to avoid possible negative impacts on the performance of the units.
- If the elevation drop difference is greater than 24", an Oil Trap must be installed (see illustration below)

**Indoor Unit is higher than Outdoor Unit**

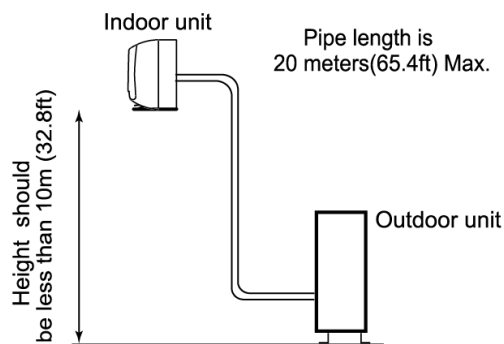

**Outdoor Unit is higher than Indoor Unit**

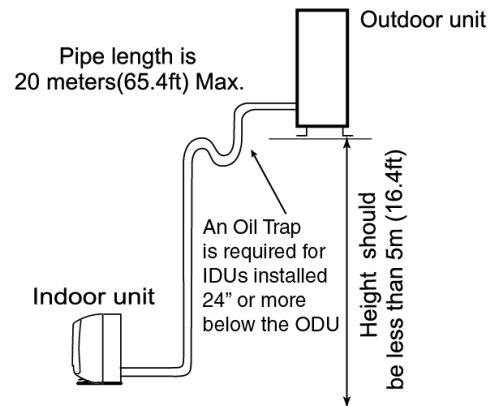

## Refrigerant Pipe Min/Max Length, Rise, and Drop Height

Btu	Min. Length (ft.)	Max. Length (ft.)	Max. Rise Height (ft.)	Max. Drop Height (ft.)
9k-12k	15	50	20	28
18k-24k	15	75	25	35
30-36k	15	100	35	50

# REFRIGERANT SYSTEM DIAGRAM

WMMS-30CH-V2B(59)4  
 WMMS-36CH-V2B(59)4  
 WMMS-42CH-V2B(59)4

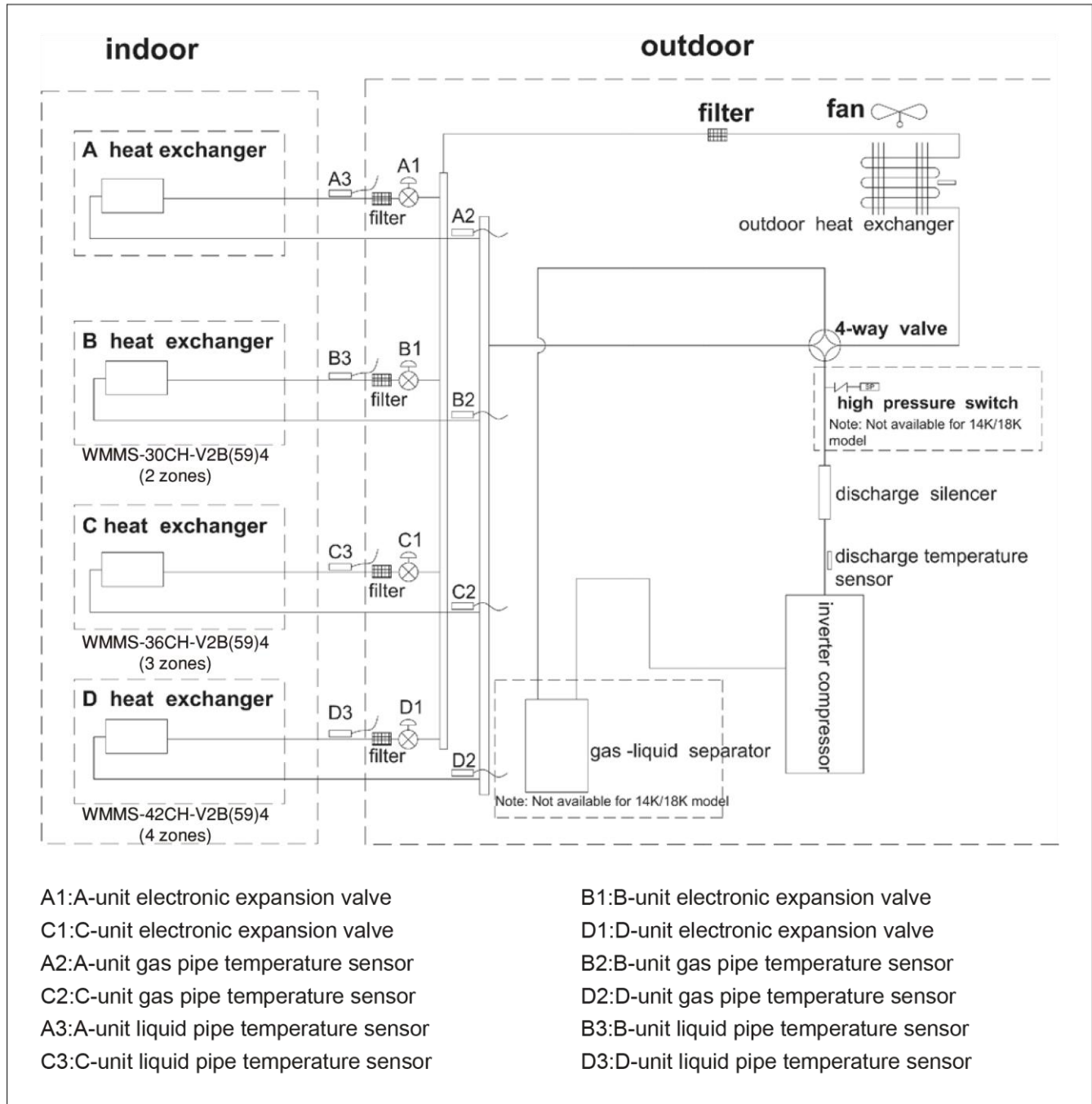

# REFRIGERANT SYSTEM DIAGRAM

WMMS-48CH-V2B(59)4  
WMMS-60CH-V2B(59)4

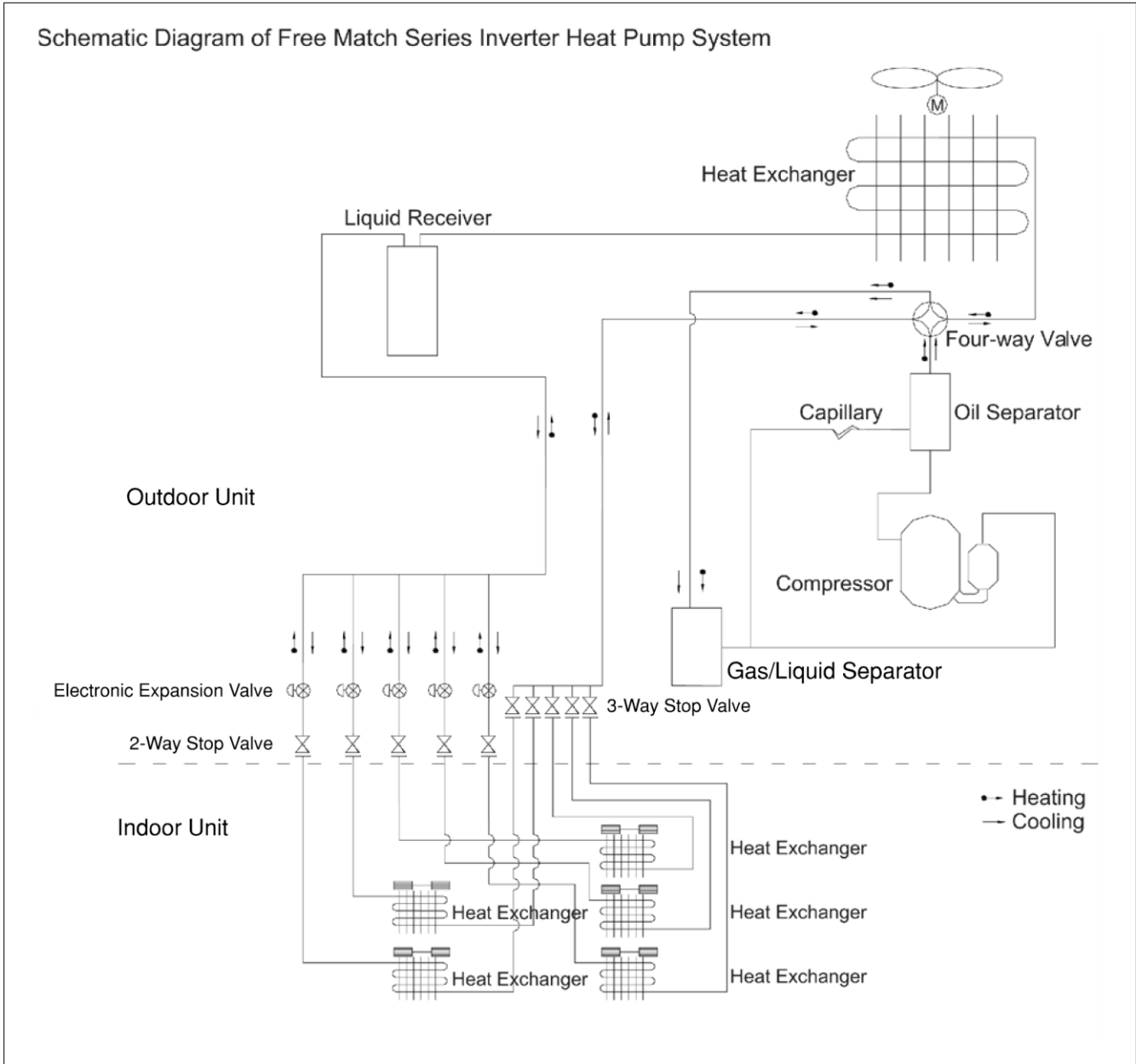

## CONNECTION OF WIRES

### WIRING AT INDOOR UNIT AND OUTDOOR UNITS

- Open the front cover panel.
- Remove screws from electrical box cover and put screws in secured position.
- Remove screws from fastener and put screws in secured position.
- Prepare wires of right size and grade.
- Recommend to use factory-provided wire/cables.
- Connected to the terminals following wiring diagrams (terminal or color matches).
- Clamp power/control wires to the structure to keep the tension from being transmitted to the wire connection.
- Replace screws or fasteners back to where they were.

**Note:**

- The environment conditions must be taken into consideration when the connections of power cable are made (such as the ambient temperature, direct exposure to heat exposure to sunlight).
- The specifications for the power cable refer to the minimum values of the metal core wires, taking into consideration the voltage losses, the core wire of power cable must be one size larger than the specifications.
- The grounding wire must be connected to the indoor units and outdoor units.
- The laying of power cables must be done by qualified electricians and comply with the regulations of the local power supply authorities and with the standards of the electric appliance.

## WIRING OUTDOOR UNIT

### CONNECT WIRING BETWEEN OUTDOOR UNIT AND INDOOR UNIT

- Check the nameplate for rated electrical data. Connect unit to the correct electrical power source.
- Select power wire of proper type and size. Suggest to use UL approved 105°C/221°F multi-strand copper wire for outdoor use. Refer to the following tables, for proper selection of wire gauge, size and circuit breaker.

### OUTDOOR WIRING: OUTDOOR-INDOOR UNIT & DISCONNECT SWITCH BOX/CIRCUIT BREAKER/FUSE

- Remove the wiring diagram cover where the handle for moving unit is located.
- Following the wiring diagrams on the unit or the wiring diagram manual that comes with the indoor unit to get familiar with the wiring to make sure everything is correct. If there are a discrepancies, always use the diagram that is attached to the units.
- Connect wires between indoor unit and outdoor unit-power wire from outdoor to Indoor, control wires from Indoor unit to outdoor unit. Pass wire through certified wire pipes, harnesses and knockouts. Enough length should be left for future servicing. Only copper wire is allowed.
- Strictly follow NEC or state or local codes to select wires, circuit breaker, conduits while performing installation work
- Bring in line-voltage power input wires from circuit breaker to line-voltage wire terminal block at outdoor unit. Pass through certified wire pipes, harnesses and knockouts. Enough length should be left for future servicing. Only copper wire is allowed.



Disconnect switch box for outdoor unit



Non-Metallic Power Whip for Outdoor Use (Field-Supplied, Not Spliced and Not Knotted, Water-Proof Sealed Tight, UL Approved)

Unit	Connection Copper Pipe Sizes	Min/Max. Length	+/- Elevation	Wires from Outdoor to Each Indoor Unit	Mini. Wire Size from Outdoor to Circuit Breaker	HVAC Type Circuit Breaker
30CH	2 x (1/4+3/8")	15/75	25/35	N(1)/2/3/G	10AWG	25AMP
36CH	3 x (1/4+3/8")	15/75	25/35	N(1)/2/3/G	10AWG	30AMP
42CH	4 x (1/4+3/8")	15/75	25/35	N(1)/2/3/G	10AWG	40AMP
48CH	5 x (1/4+3/8")	15/75	25/35	N(1)/2/3/G	8AWG	40AMP
60CH	5 x (1/4+3/8")	15/75	25/35	N(1)/2/3/G	8AWG	50AMP

## ELECTRICAL CONNECTIONS

- 1) Remove the handle or cover on the right side plate of the outdoor unit.
- 2) Remove the cable clamp. Connect the interconnecting power cable to the terminal block and secure the connection. Make sure that your interconnecting wires are attached to the same terminal on the outdoor unit. (white wire on the ODU terminal 1, should be wired to terminal 1 on the IDU)
- 3) Fix power connection wire by wire clamp.
- 4) Ensure wire has been fastened well.
- 5) Replace handle or cover when done.

- ⚠ An all-pole disconnect switch having a contact separation of at least 0.12" should be connected inline to all fixed wiring.
- ⚠ Incorrect wire connections may cause malfunction or damage to some electric components.
- ⚠ After fixing cable, ensure that leads between connections to fixed point have some space.
- ⚠ The connection pipes and the connection wiring of the unit A and unit B must correspond to each other respectively.
- ⚠ The appliance shall be installed in accordance with national wiring regulations.
- ⚠ Do not install the outdoor unit where it is exposed to constant sunlight.

## WIRING INDOOR - OUTDOOR 30CH UNIT

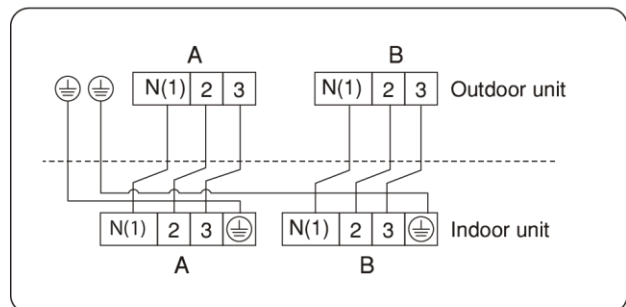
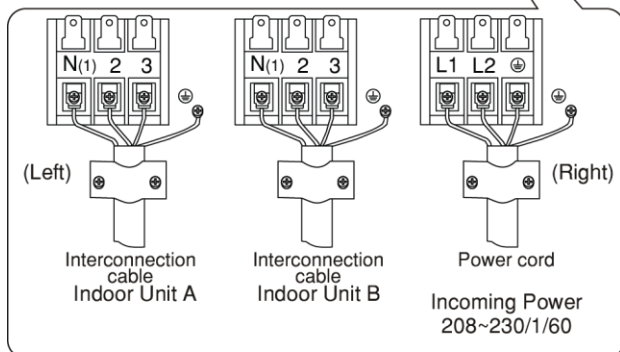
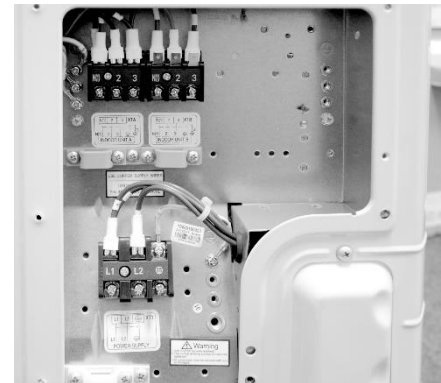
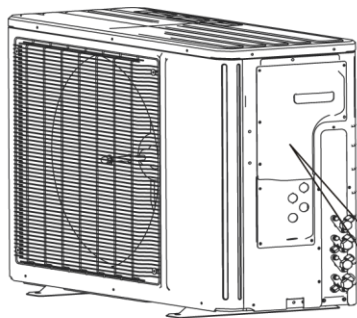

## WIRING INDOOR - OUTDOOR 36CH UNIT

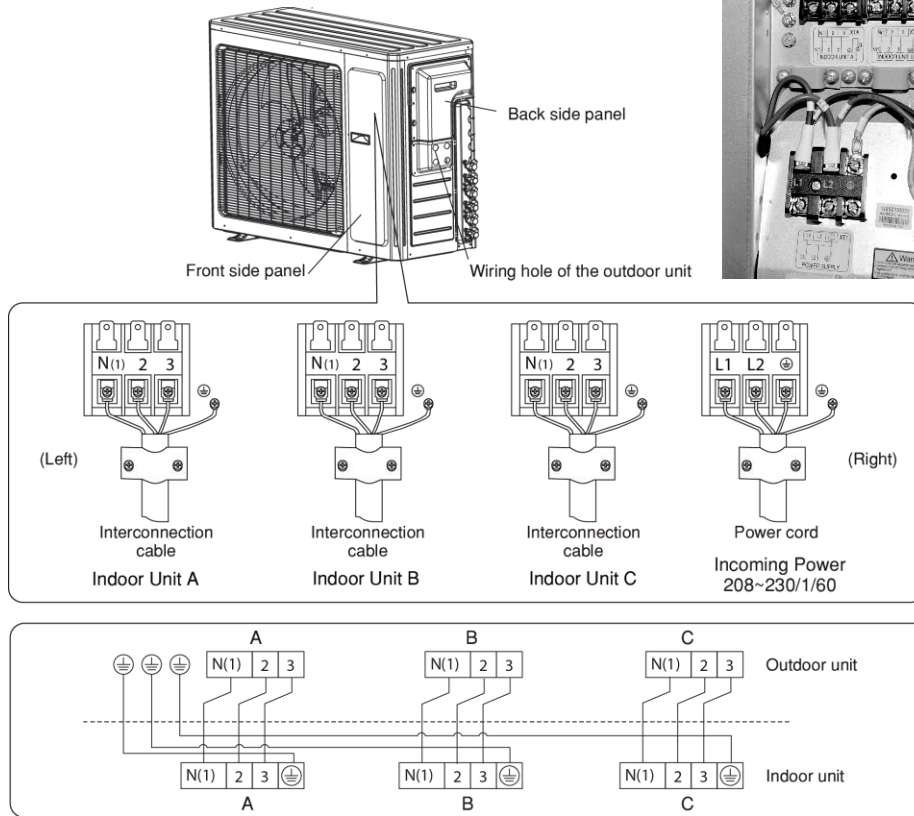

## WIRING INDOOR - OUTDOOR 42CH UNIT





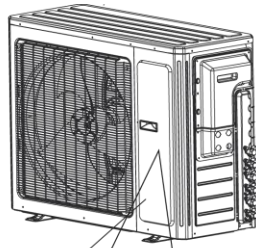

Front side plate

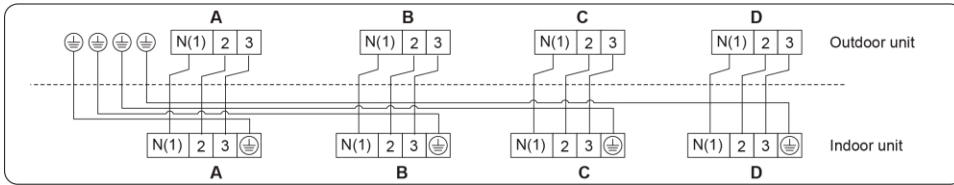
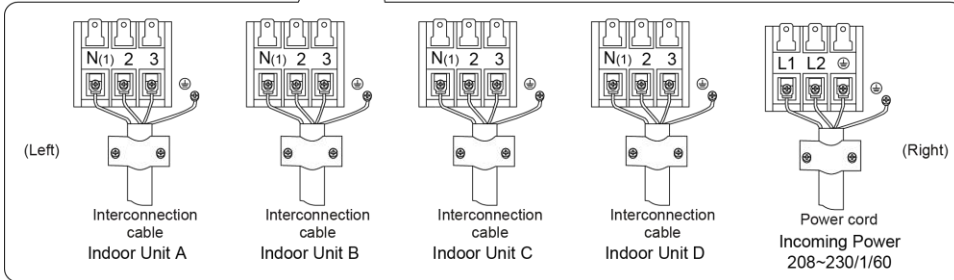

## WIRING INDOOR - OUTDOOR 48CH-60CH UNIT



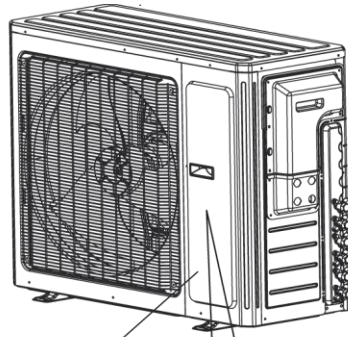

Front side plate

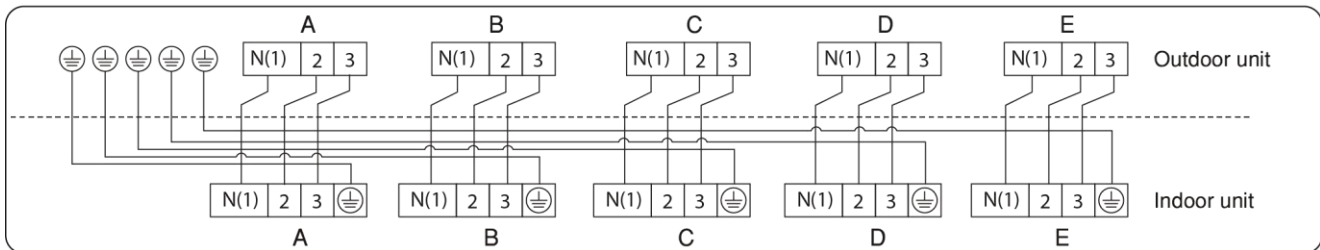
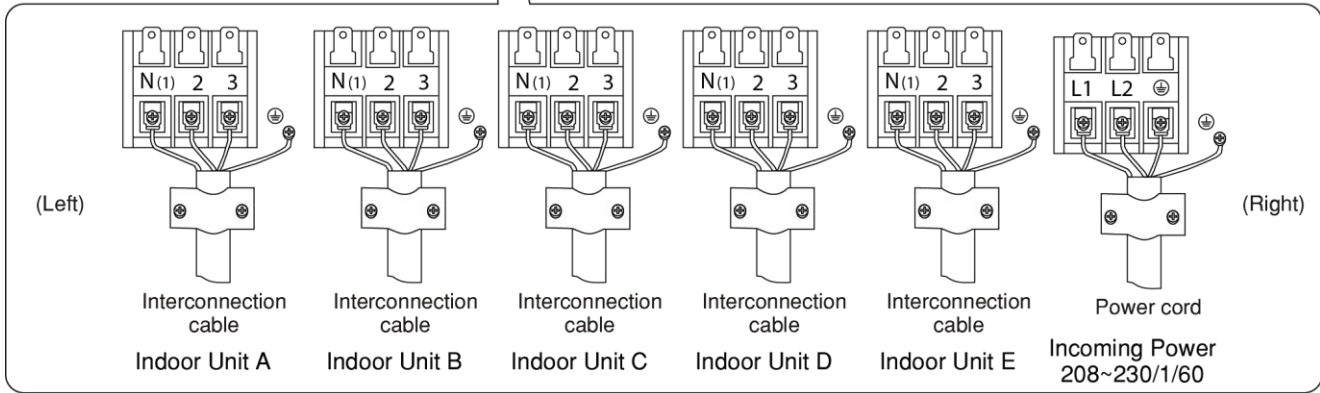



# WIRING DIAGRAMS

The schematics below are provided as a reference, but all YMG I Outdoor Units have a wiring schematic on the inside of the unit which will be the most accurate information about your unit. YMG I products are constantly being improved, because of this, the schematics below may not reflect changes or improvements on your unit.

WMMS-30CH-V2B-(59)4

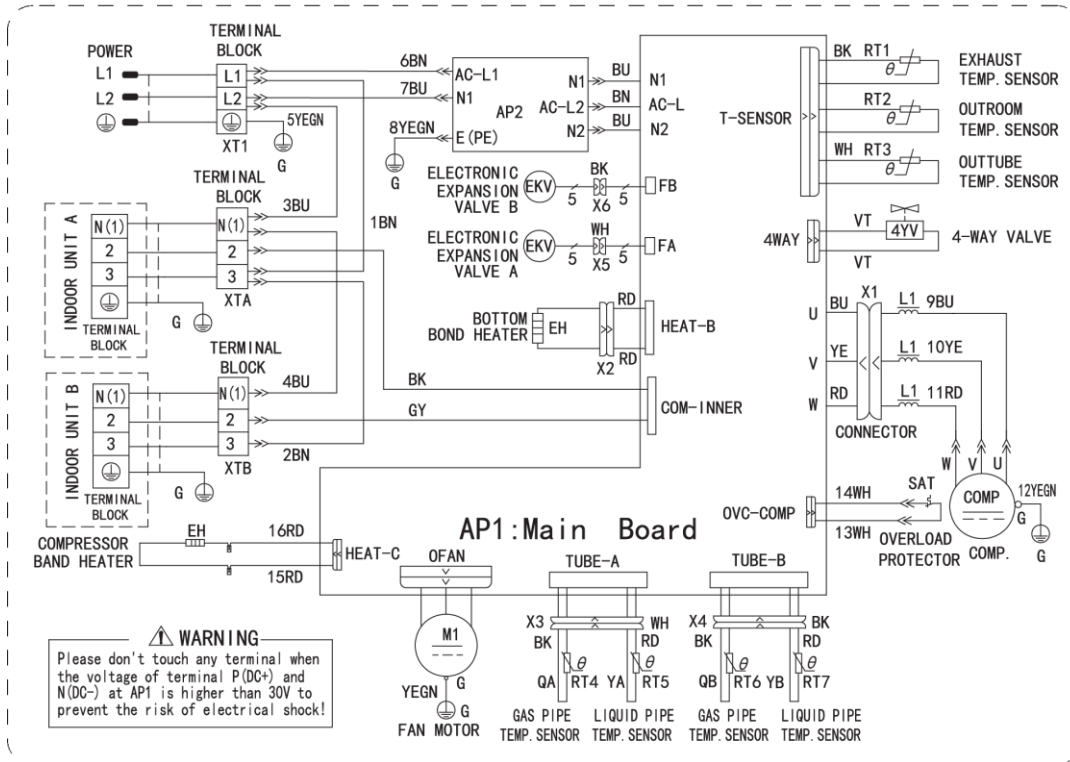

WMMS-36CH-V2B-(59)4

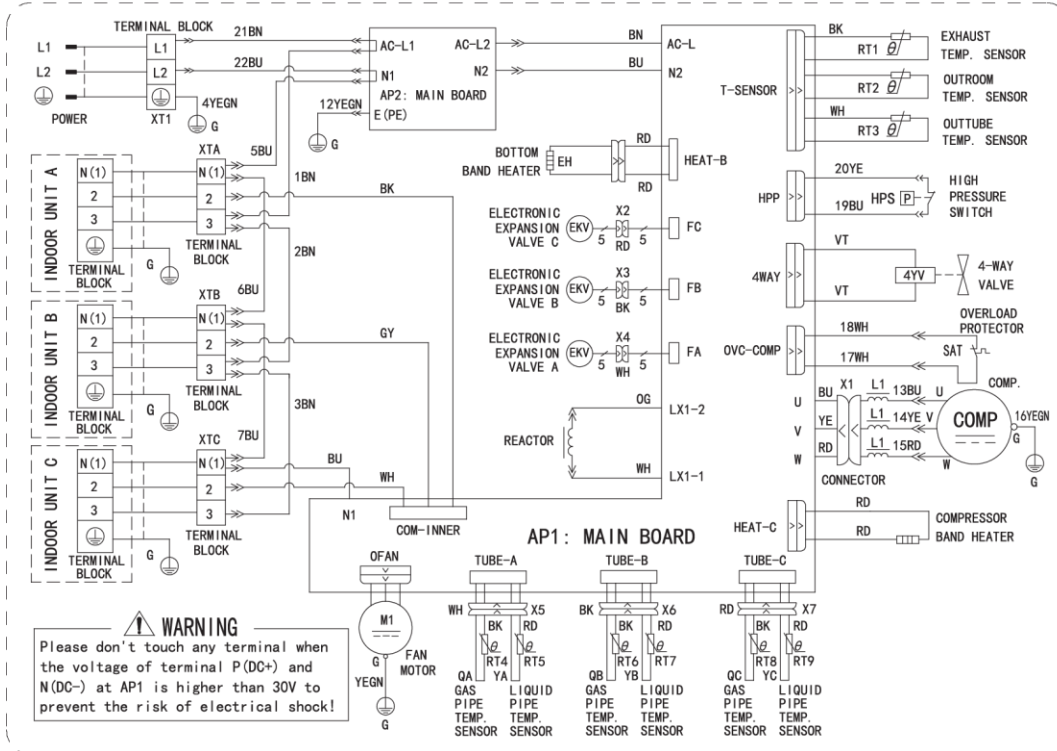

WMMS-42CH-V2B-(59)4

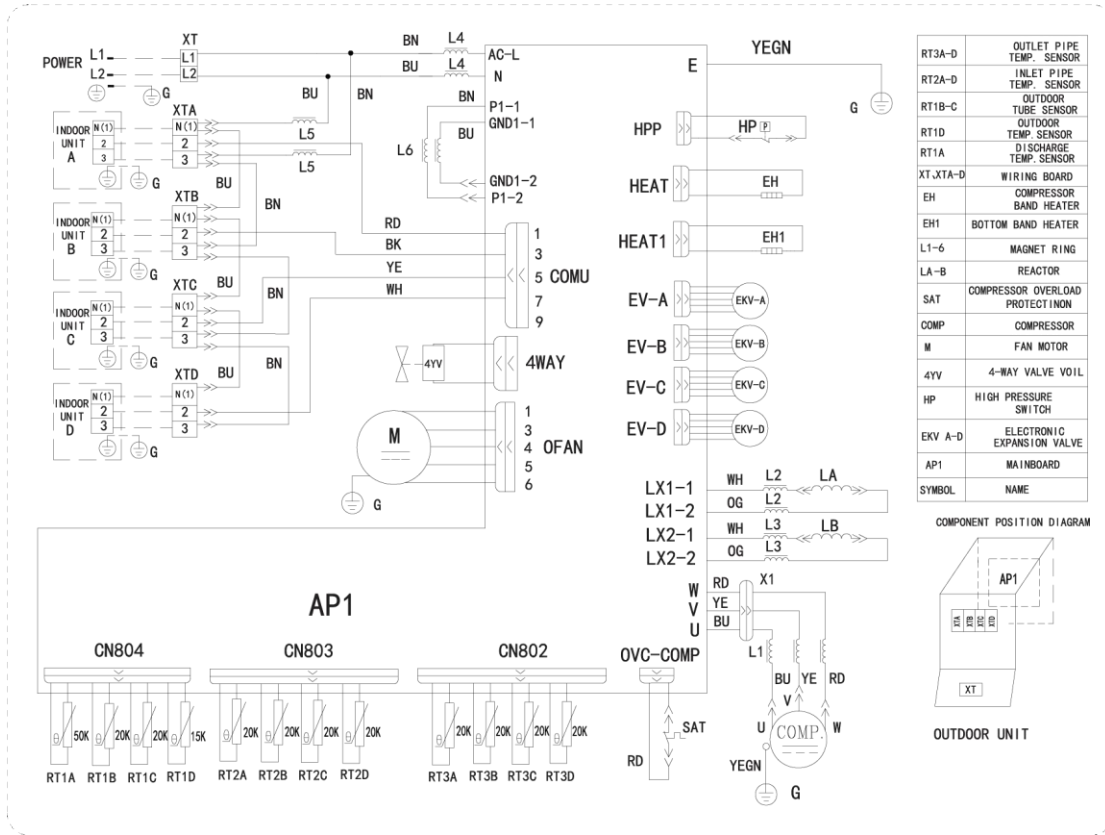

WMMS-48CH-V2B-(59)4 and WMMS-60CH-V2B-(59)4

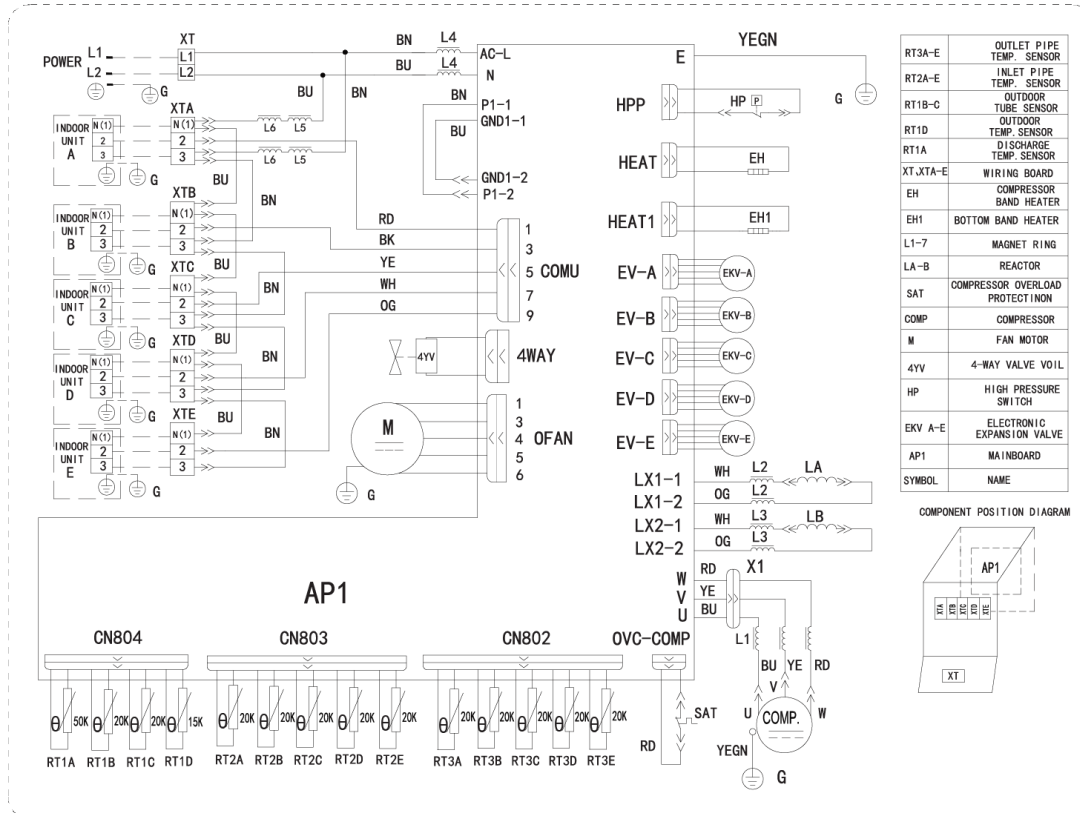

# DO NOT CROSS-WIRE & DO NOT CROSS-PIPE

## ⚠ WARNING

There are multiple electronic expansion valves built into the Outdoor Unit, with one (1) for each indoor unit, so wiring and piping for each Indoor Unit need to match with the corresponding wiring terminals and valves for that specific Indoor Unit.

**Do NOT Cross Pipe or Cross Wire between any two indoor units.**

All manufacturer's warranties will be voided if the unit is cross piped or cross wired during installation. Manufacturer or Distributor WILL NOT be responsible for any direct or indirect damages or losses caused by an incorrect installation.

### Negative Impact of Cross Wiring or Cross Piping between any Two Zones

1. The compressor may pump refrigerant into the wrong connected indoor unit, when a different unit is transmitting for cooling or heating
2. Conditioned air will not blow out of the desired indoor unit, and it will not heat or cool as needed.
3. May freeze (during cooling) or heat up (when heating) the wrong Indoor Unit.
4. Can cause damage to compressor or other refrigeration components
5. May cause electrical surge
6. May damage the whole unit
7. Can cause other consequential damages
8. Voids manufacturer's warranty
9. Installer MUST take full responsibility for damage if the system is installed incorrectly.

Wiring should go between each Indoor Unit and the Outdoor Unit.

Connection at N(1)/2/3, in a one to one match: A-A, B-B, C-C, D-D, etc.

Power Cable from Disconnect Switch Box to Connect to Outdoor Unit Terminal Block L1/L2/G 208~230/1/60

### Refrigerant Piping:

Ensure the liquid and gas lines from indoor unit A are connected to the valves on the outdoor unit marked A/A.

Also make sure that the liquid and gas lines from Indoor unit B are connected to the valves on the Outdoor Unit B/B.

Same matching on C-C, D-D etc.

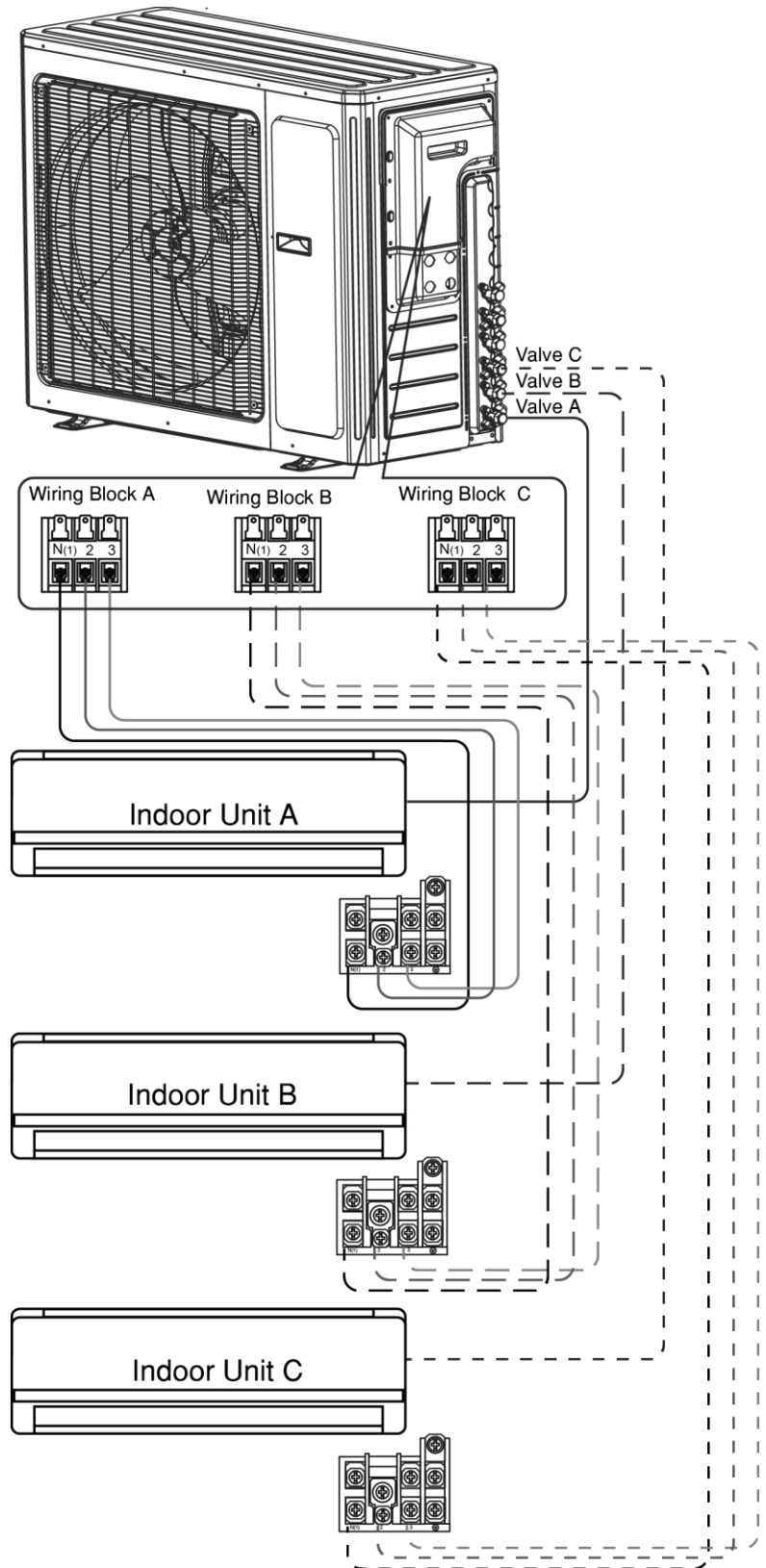

# INSTALLATION OF ACCESSORIES

## CONNECT REFRIGERANT PIPES

### Seal Copper Line Set/Wire Cable/Drain Hose Line Combination:

- Use factory-recommended components, as briefly illustrated below.
- Cover line set in a sequence, either from indoor to outdoor, or the other way.
- Secure line set covers onto the wall using factory-recommended accessories.

## LINE SET COVERS

### ⚠ CAUTION

Do not damage line sets.



## OUTDOOR UNIT FOOT RISER OR BRACKETS

### BRKT-XXXX-SC1

- Made of steel.
- Coated with weatherproof polyester powder.

Model	Size(Inch)		Capacity	
	A	B	LBs	Btu/h
BRKT-0918-SC1	17.7	15.4	320	09K-18K
BRKT-1860-SC	21.7	18.3	360	18K-60K



### BRKT-XXXX-ST1

- Made of stainless steel.

Model	Size(Inch)		Capacity	
	A	B	LBs	Btu/h
BRKT-0918-ST1	17.7	15.4	320	09K-18K
BRKT-1860-ST1	21.7	18.3	360	18K-60K



### RIST-XXXX-PVC

- Foot Riser
- Accessories: End Caps (Optional)
- Shock-proof PVC, Weatherproof & UV resistant.
- Supplied with fastening screws and anchor bolts.
- Easy to install.
- Honeycomb structure acts as an anti-vibration & humming absorption for quiet operation.

Model	Size(Inch)				Capacity	
	A	B	C	D	LBs	Btu/h
RIST-0918-PVC	14.2	3.7	3.1	4.1	220	09K-18K
RIST-1860-PVC	17.7	3.7	3.1	4.1	260	18K-60K



# VACUUM TESTING AND CHARGING

## CHECK LEAKAGE BEFORE CHARGING IDU

### VACUUM REFRIGERANT PIPES

Evacuate the pipes between indoor and outdoor units, using vacuum pump and manifold/gauge set, to a minimum of 500 microns (service valves remain front seated). Turn off manifold valve (low) to check if the vacuum level is maintained for a minimum of 60 minutes. Be certain there is no pressure in the system when repairing a leak.

### Vacuum and Check Leakage before Releasing Refrigerant from Outdoor Unit to Indoor Unit

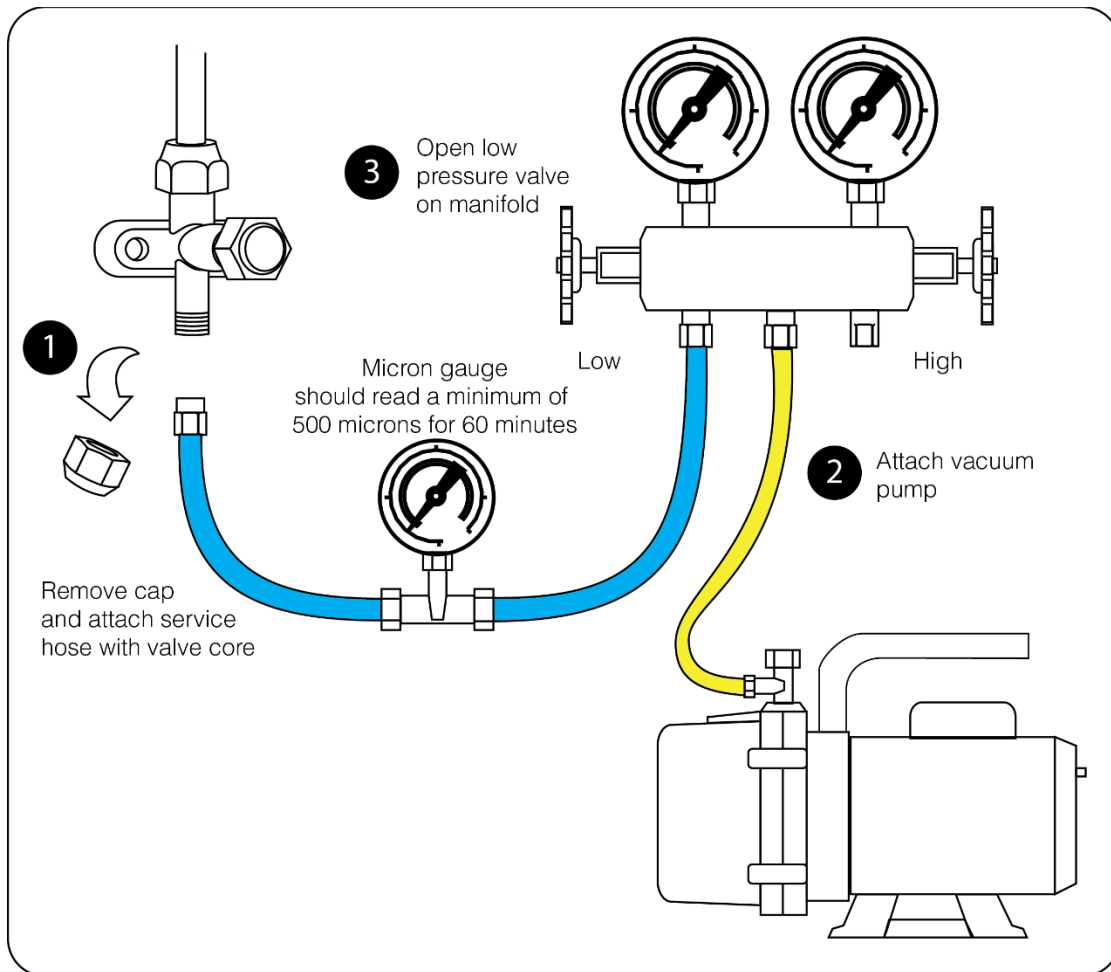

For Multi-Zone systems repeat this process for each zone with indoor units attached to it.

If all zones are not being used, check the flared nuts on the unused valves, and ensure that they are tightened to avoid any potential system leaks.

# SYSTEM INSPECTION AND TRIAL RUNNING

Unit is pre-charged with refrigerant good for 25' of connection tubes. If vacuum is held for about 30 minutes and no leak is found, first back-seat the liquid (smaller) service valve by Allen Wrench (hex head) slowly to release pre-charged refrigerant from the condensing unit into the connection pipes and indoor unit. If no abnormal things are found, fully open liquid (smaller) and gas (bigger) service valves. Always replace and tighten the caps onto service valves.

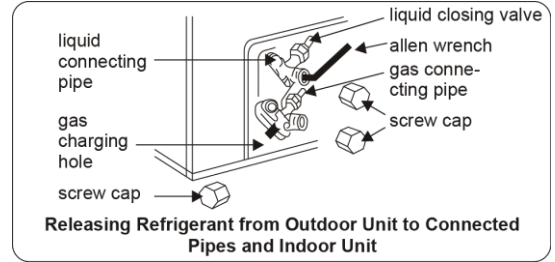

## CHECK SYSTEM THOROUGHLY

Check system thoroughly to make sure the unit is ready for trial running: check wires and pipes and air intake and discharge and power and thermostat and others necessary components.

## ADJUST REFRIGERANT-GUIDELINE

The right amount of refrigerant is very important. It is one of the basics to ensure safe operation of the unit over time. Normally single zone outdoor unit is pre-charged with refrigerant for 25 ft. inter-connecting copper (liquid) line. Multiple zone outdoor units are pre-charged for various length of copper (liquid) lines of allowed quantity of indoor units, following specs or engineering submittal.

For single zone unit or multiple zone multiple compressor unit, normally the outdoor unit is pre-charged for 25ft line sets. If the copper line is longer or shorter than 25ft, you will need to add or remove refrigerant, following general rule of thumb for rough adjustment:

- 1/4" liquid line unit: 0.23 Oz/ft.
- 3/8" liquid line unit: 0.4 OZ/ft.
- 1/2" liquid line unit: 1.2 OZ/ft.

For multiple zone single compressor units, if the copper line is longer or shorter than the length at which pre-charged refrigerant is good for, as listed in the engineering submittal or related labels or tables, need to add or deduct refrigerant, following 0.23 OZ/ft. rule of thumb for rough adjustment.

In all situations, the minimum copper line (liquid or gas) length for each indoor unit is 15ft. For a better adjustment, you may combine above guideline with the indoor or outdoor (ambient) temperature-refrigerant pressure chart, or generally 8-12 °F super-heat method.

		Model	WMMS-30CH-V2B(59)4	WMMS-36CH-V2B(59)4	WMMS-42CH-V2B(59)4	WMMS-48CH-V2B(59)4	WMMS-60CH-V2B(59)4
Valve sizes at outdoor unit	Liquid valve	In.	2 x 1/4	3 x 1/4	4 x 1/4	5 x 1/4	5 x 1/4
	Gas valve	In.	2 x 3/8	3 x 3/8	4 x 3/8	5 x 3/8	5 x 3/8
Max. pipe length (add up length of all liquid lines only), if not upper sizing pipes		Ft.	120	200	230	260	300
Max. installed indoor and outdoor unit elevation difference	Outdoor unit is installed below the indoor unit	Ft.	15	25	30	30	30
	Outdoor unit is installed above indoor unit	Ft.	25	25	30	30	30
Max. pipe length, if not adjusting factory pre-charged refrigerant		Ft.	60 (add up length of all liquid lines only)	100 (add up length of all liquid lines only)	100 (add up length of all liquid lines only)	130 (add up length of all liquid lines only)	130 (add up length of all liquid lines only)
Minimum pipe length (for each indoor unit)		/	15 ft.				
Refrigerant charge adjustment, if actual length is different from the number in the line above		+/- Oz/Ft	0.23				





- Adjust refrigerant charge, following instructions, if the actual installation elevation difference is different from 7' and length is different from the listed numbers above.
- Any indoor unit is 30' or more apart from the outdoor unit, better to adjust refrigerant. If it is 50' or more apart, better to upper size the copper lines and adjust refrigerant.
- Any run cannot be more than 100' apart from the outdoor unit; otherwise, that indoor unit's capacity may be decreased too much.

## SYSTEM INSPECTION AND TRIAL RUNNING

### PRESSURE TABLES

System pressure checking should be a must-do job during trial running of initial installation, and compressor/refrigerant-related troubleshooting. It is a more accurate refrigerant adjusting method than rough refrigerant addition or deduction guideline shown above.

In some cases, if the service valve on unit is 5/16 and your service valve connection is 1/4, need to use a 5/16 -1/4 adaptor so that you can connect to your manifold. Need to pay attention to use the right manifold that is rated for the refrigerant in the unit, and pay attention to connect to the correct hose (blue hose for low pressure, red hose for high pressure, yellow hose for vacuum or charging or deduction).

It is NOT recommended to the put hose onto service valve while compressor is running. Remove hose quickly and carefully to avoid air suck-in, refrigerant leakage, or any refrigerant-freezing burn.

The following curves are only reference for system pressure checking. Actual pressures may vary upon many factors such as inter-connecting pipe length, refrigerant charge / leakage level, elevation difference between indoor unit and outdoor unit, tool calibration, reading error, and so on.

### Reference Temperature-Pressure Table (Split Condensing Unit-R410A AC)

#### Product Series: YMGI Group-Mini Split

Outdoor Dry-Bulb (F)	15	25	35	50	55	60	67	75	82	90	95	100	105	110	115
Outdoor Dry-Bulb (C)	-9.4	-3.9	1.7	10.0	12.8	15.6	19.4	23.9	27.8	32.2	35.0	37.8	40.6	43.3	46.1
Outdoor Wet-Bulb (F)	13.6	23.0	30.2	42.8	46.9	51.1	59.5	66.6	64.9	71.2	75.0	79.0	82.9	86.9	90.7
Outdoor Wet-Bulb (C)	-10.2	-5	-1.0	6.0	8.3	10.6	15.3	19.2	18.3	21.8	23.9	26.1	28.3	30.5	32.6
Indoor Dry-Bulb	80F (26.7C)														
Indoor Wet-Bulb	67F (19.4C)														
Discharge-PSI/F	74/21.2	84/27.1	105/35.1	115/38.5	125/42.8	130/45.5	140/48.2	146/51.2	156/54.3	166/57.5	175/61.2	180/62.5	186/63.7	189/64.5	191/64.9
Suction-PSI/F	60/46.2	70/53.5	85/55.2	92/55.7	98/56.1	103/56.7	110/56.9	115/57.1	120/57.5	128/57.8	135/57.9	136/58.6	137/59.1	139/59.3	140/59.5
	Suggest to Add on Low Ambient Control, If Still in Need of AC for Long Time In Cold Weather. Closely Check/Watch Refrigerant Charge Level.														
	Warning: R410A refrigerant bears higher pressures than R22. Only handled by Licensed HVAC technician.														

### Reference Temperature-Pressure Table (Split Condensing Unit, R410A-Heat Pump)

#### Product Series: YMGI Group-Mini Split System Version: 01/11/2010

Outdoor Dry-Bulb (F)	0	5	10	17	25	30	35	40	45	47	55	62
Outdoor Dry-Bulb (C)	-17.8	-15	-12.2	-8.3	-3.9	-1.1	1.7	4.4	7.2	8.3	12.8	16.7
Outdoor Wet-Bulb (F)	-0.8	4.1	8.8	15	22.8	27.5	28.9	36.3	41.0	43.0	50.4	56.5
Outdoor Wet-Bulb (C)	-18.2	-15.5	-12.9	-9.4	-5.1	-2.5	-1.7	2.4	5	6.1	10.2	13.6
Indoor Dry-Bulb	70F (21.1C)											
Indoor Wet-Bulb	60F (15.6C)											
Discharge-PSI/F	260/84	269/90	284.5/95	290/102	296/111	304/128	304/133	330/138	345/142	354/149	400/149	440/176
Suction-PSI/F	246/72	255/78	270/86	278/89	285/92	290/95	310/98	318/100	330/102	340/104	380/107	425/113





## BASIC FUNCTIONS OF THE SYSTEM

### Cooling Mode

- Cooling conditions and process:  
If the compressor is in stop status and you start the unit for cooling operation, when one of the indoor units reaches the cooling operation condition (the temperature of the room is higher than the set temperature), the unit will start cooling operation. The electronic expansion valve, the outdoor fan and the compressor start operation.
- Stop in cooling operation
  1. Compressor stops:  
The compressor will stop immediately. The outdoor fan will stop after 1 minute.
  2. If only some of the indoor units reach the stop condition (reaches the set temperature) (the compressor does not stop). The compressor operates immediately according to the required frequency. For the indoor unit with no requirement, the corresponding electronic expansion valve is closed to OP.
- Cooling mode transitions to heating mode:  
When the unit transitions to heating mode, the 4-way valve is energized after the compressor stops for 2 minutes. The other disposals are the same as stopping in cooling mode.
- 4-way valve:  
In this mode, the 4-way valve switches the direction of the refrigerant flow.
- Outdoor fan control in cooling mode:  
The outdoor fan starts 5 seconds before the starting of compressor. The outdoor fan will run in high speed for 3 minutes after starting and then it will run at set speed. The fan should run at every speed for at least 80 seconds. (When the quantity of running indoor units is changed, the unit will enter the control described in 1.3.5.1 and 1.3.5.2).  
When the compressor stops, the outdoor fan runs at present speed and stops after 1 minute.

### Dry Mode

- The dry conditions and process are the same as those in cooling mode
- The status of 4-way valve: unenergized
- The temperature setting range: 61 °F ~ 86 °F.
- Protection function: the same as those in cooling mode;
- In dry mode, the maximum value A of the capacity requirement percentage of single unit is 90% of that in cooling mode. The open condition of the electronic expansion valve, outdoor fan and compressor is the same as those in cooling mode.

### Heating Mode

- Heating conditions and process:  
When one of the indoor units reaches the heating operation condition (falls below the set indoor temperature), the unit starts heating operation.
- Stop in heating operation:
  1. When all the indoor units reach the stop condition (reaches the set temperature), the compressor stops and the outdoor fan stops after 1 minute.
  2. Some of the indoor units reach the stop condition  
The compressor reduces the frequency immediately and operates according to the required frequency
  3. Heating mode transfers to cooling mode (dry mode), fan mode
    - a. The compressor stops;
    - b. the 4-way valve deenergizes after 2min
    - c. the outdoor fan stops after 1min;
    - d. the status of 4-way valve: deenergized
- Outdoor fan control in heating mode  
The outdoor fan starts before 5s of the starting of compressor and then it will run in high speed for 40seconds  
The fan shall run at every speed for at least 80 seconds  
When the compressor stops, the outdoor fan stops after 1 minute
- Defrosting function  
When the defrosting condition is met, the compressor stops; the electronic expansion valve of all indoor units opens to a large angle; the outdoor fan stops after 40 seconds of the compressor stopping, the 4-way valve reverses direction; after the 4-way valve reverses the direction, the compressor starts; then begins to calculate the time of defrosting, the frequency of the compressor rises to reach the defrosting frequency.

- Oil-returned control in heating mode
  1. Oil-returned condition  
The whole unit is operating in low frequency for a long time
  2. Oil-returned process in heating mode  
The indoor unit displays "H1"
  3. Oil-returned finished condition in heating mode  
The duration reaches 5 minutes

### Fan Mode

The compressor, the outdoor fan and the 4-way valve is unenergized; temperature setting range is 61°~86°F.

## PROTECTION FUNCTIONS

### Mode Conflict Protection of indoor unit

When the setting modes are different on indoor unit, the unit runs in below status:

- a. The mode of the first operating indoor unit is the basic mode. Compare the mode of the other indoor units to see if there is a conflict. Cooling mode (or dry mode) will cause a conflict with heating mode.
- b. Fan mode is in conflict with heating mode and the heating mode is the basic mode. No matter which indoor unit operates first, the unit will run in heating mode.

### Overload protection function

When the tube temperature is low, the compressor raises the operation frequency.

When the tube temperature is high, the compressor frequency is restricted or lowers the operation frequency.

When the tube temperature is too high, the compressor protection stops running.

If the discharge temperature protection continuously triggers 6 times, the compressor can't resume running.

The compressor can be reset to run after cutting off the power and then restoring the power. (If the compressor runs continuously without fault for longer than 7 minutes, the protection fault trips recorded will be cleared)

### Discharge Protection Function

When the discharge temperature is a low, the compressor raises the operation frequency.

When the discharge temperature is a high, the compressor frequency is restricted or lows down the operation frequency.

If the discharge temperature protection continuously triggers 6 times, the compressor can't resume running.

The compressor can be reset to run after cutting off the power and then restoring the power. (If the compressor runs continuously without fault for longer than 7 minutes, the protection fault trips recorded will be cleared)

### Communication Malfunction

Detection of the quantity of installed indoor units:

After 3 minutes of energizing, if the outdoor unit does not receive the communication data of a certain indoor unit, the outdoor unit will judge that indoor unit is not installed and will treat it as if it is not installed. If the outdoor unit receives the communication data of that indoor unit later, the outdoor unit will treat that unit as if it is installed.

### Overcurrent Protection

- a. Overcurrent protection of complete unit
- b. Phase wire current protection
- c. Compressor phase current protection.

### Compressor high-pressure protection

- When the high-pressure switch is detected cut off for 3 seconds continuously, the compressor will enter high-pressure protection as it stops when reaching set temperature. Meanwhile, the outdoor unit will send the signal of "high pressure protection" to the indoor units.
- After displaying a high-pressure protection warning, when the high-pressure switch is detected closed for 6 seconds continuously, the compressor can be reset and resume running after cutting off the power and then restoring the power.

### Compressor overload protection

If the compressor overload switch is detected having movement, the indoor unit will display the corresponding malfunction as it stops when the indoor temperature reaching set temperature. When the compressor stops for more than 3min and the compressor overload switch is reset, the unit will resume operation status automatically.

If the protection appears for more than 6 times (if the running time of the compressor is longer than 30min, the protection times record will be cleared). The unit cannot resume operation status automatically, but can be reset to resume operation by cutting the power and then restoring the power.

### IPM Protection

- When the IPM module protection is detected, the unit will stop as the indoor temperature reaching set temperature, PFC is closed, display IPM protection malfunction. After the compressor stops for 3 minutes, the unit will resume operation status automatically
- If the IPM protection is detected for more than 6 times consecutively the system will stop and send the signal of module protection to indoor unit.  
(If the uninterrupted running time of the compressor is longer than 7 min, the protection times recorded will be cleared),
- If the unit cannot resume operation status automatically, the unit can be reset to resume running after cutting off the power and then restoring the power

### IPM module overheating protection

- When  $TIPM \geq 185^{\circ}F$ , prohibit to raise frequency;
- When  $TIPM \geq 194^{\circ}F$ , the operation frequency of compressor slows down by 15% every 90s according to the present capacity requirement of the complete unit. It will keep 90s after lowering the frequency.
- After lowering the frequency, if  $TIPM \geq 194^{\circ}F$ , the unit will circulate the above movement until reaching the minimum frequency; if  $185^{\circ}F < TIPM < 194^{\circ}F$ , the unit will run at this frequency; when  $TIPM \leq 185^{\circ}F$ , the unit will run at the frequency according to the capacity requirement
- When  $TIPM \geq 194^{\circ}F$ , the compressor stops. After the compressor stops for 3 minutes, if  $TIPM \leq 185^{\circ}F$ , the compressor and the outdoor fan will resume operation.

## ABOUT MODE CLASH/CONFLICT BETWEEN INDOOR UNITS

If any two indoor units are controlled to run in the following modes, the indoor unit will run into mode clash or conflict. All indoor units will stop to run and show **Protection/Error code E7**, unless the unit is turned-off and then turned back on:

Some on **HEAT** Mode, while others on **COOL** Mode and/or **DRY** (Dehumidify) Mode and/or **FAN** Mode.

### NOTE:

**COOL** mode is compatible with **DRY** and **FAN** mode. In other words, there will be no problem for some indoor units to run **COOL**, while others may run either one or few of modes **COOL**, **DRY** (Dehumidifying) and **FAN**. No **Protection/Error** code will show up.

## OPERATION AT EMERGENCY

If at any time the remote control becomes damaged or lost, you can switch to **Manual** mode on the indoor unit. This will allow the unit to run in **AUTO** mode only. While in **AUTO** mode the unit temperature cannot be switched. Contact your local service provider for instructions on replacing the remote control.

### The manual switch can be operated as follow:

- **Operation:** When the unit has stopped running, press **ON/OFF** button, unit will enter **AUTO RUN** mode. The microcomputer will acquire the room temperature to select the (**COOL, HEAT, FAN**) mode automatically, to obtain the correct setting.
- **Stopping:** When the unit is running, press the **ON/OFF** button of the manual switch, the unit will stop working.

### The code switch can be operated as follow:

- **Operation:** When the unit has stopped running, adjust the code switch to **AUTO**, the unit will enter **AUTO RUN** mode. The microcomputer will acquire the room temperature to select the (**COOL, HEAT, FAN**) mode automatically, to obtain the correct setting.
- **Stopping:** When the unit is running, adjusts the code switch to the **STOP** position, the unit will stop working.

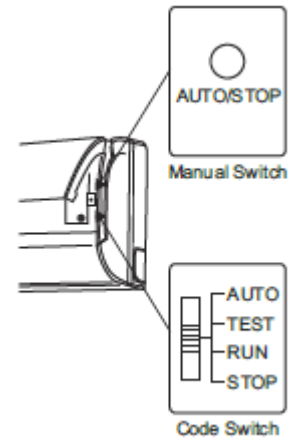

## PROTECTION AND ERROR CODES

### Check before Contacting Service Center

Please check the following items before contacting the maintenance serviceman.

Conditions	Causes	Corrective Actions
The Unit will not run	Broken fuse or open breaker	Replace the fuse or close breaker
	Power is off	Restart the unit when the power is on
	Drained batteries in the remote control.	Change batteries
Unit stops soon shortly after starting	Clogged inlet or outlet of the indoor or outdoor unit	Clear debris or obstacle
Cooling or Heating abnormally	Clogged inlet or outlet of the indoor or outdoor unit	Clear debris or obstacle
	Improperly set temperature	Adjust the settings using the remote or wired controller
	Fan speed is set too low	Adjust the settings using the remote or wired controller
	Improper air flow direction	Adjust the settings using the remote or wired controller
	Opened door or window	Close windows and doors
	Direct sunlight	Hang or curtain or blinds over the window to shade the room
	Too many people in the room	
	Too many heat sources in the room.	Reduce the number or running appliances or other heat sources that may be running in the room.
Dirty filter	Remove, clean and replace the filters.	

**Note:** If the air conditioner still runs abnormally after the above check and handling, please contact the maintenance serviceman at the local appointed service center and also give a description of the error occurred as well as the model of the unit.

### Problem Handling

The conditions listed below are not classified into errors.

Conditions	Causes
Unit does not run	When restarted, the unit stops running after a few minutes.
	When started the unit shuts down immediately
Unit blows out mist	When cooling operation starts
Unit generates noise	Unit "clatters" at start up.
	Unit "swishes" during cooling operation.
	Unit "swishes" when it is started or stopped
	Unit "swishes" when it is on, or after running
	Unit "squeaks" when it is on, or after running
Unit blows out dust	When the unit restarts after not having been run for a prolonged period
Unit emits odor	When the unit is running

### Error Description

If an error occurs when the unit is running, the error code(s) will be displayed on the wired controller and the main board of the outdoor unit. Check the table below for more details about the meaning of each error

Malfunction	Error Code	Displayed on Lamps		
		Running Lamp /Power Lamp	Cooling Temp	Heating Temp
Fault in input power zero	U8	Blink 17 times		
Jumper cap malfunction protection	C5	Blink 15 times		
No feedback of indoor fan motor	H6	Blink 11 times		
Indoor ambient sensor open or short circuit	F1		Blink 1 time	
Indoor tube sensor open or short circuit	F2		Blink 2 times	
Inlet tube sensor malfunction	b5		Blink 19 times	
Outlet tube sensor malfunction	b7		Blink 22 times	
IPM sensor circuit malfunction	P7			Blink 18 times
Outdoor ambient sensor open or short circuit	F3		Blink 3 times	
Outdoor tube sensor open or short circuit	F4		Blink 4 times	
Exhaust sensor open or short circuit	F5		Blink 5 times	
Communications failure between outdoor and indoor unit	F6	Blink 6 times		
Compressor phase current detection circuit malfunction	U1			Blink 12 times
Compressor demagnetization protection	HE			Blink 14 times
PN voltage drop protection	U3			Blink 20 times
IPM high temperature protection	P8			Blink 19 times
Capacitor charge malfunction	PU			Blink 17 times
Refrigerant system high pressure protection	E1	Blink 1 time		
Compressor overload protection	H3			Blink 3 times
IPM Module protection. Can be caused by over-charged refrigerant/high pressure (bad manifold gauge), restricted refrigerant flow or kinks on refrigerant pipes. Board failure due to age, insects, water exposure, power surge, lightning; or high current through the control board caused by any of these: failed fan motor, damaged fan blade, dirty coils outdoor and indoor units, airflow restricted by dirty filter, kinks in the copper lines, too much refrigerant, locked compressor, or other reasons.	H5			
Loading EEPROM malfunction	EE			Blink 15 times
Wrong connection or expansion valve malfunction	Dn			
AC current detect circuit malfunction	U5		Blink 13 times	
Outdoor DC fan motor malfunction	L3	Blink 23 times		
Wrong connection or expansion valve malfunction	dd			
Recovery refrigerant mode	Fo	Blink 1 time	Blink 1 time	
Startup failure	Lc			Blink 11 times
Compressor exhaust high temperature protection	E4	Blink 4 times		
Anti-high temperature protection	E8	Blink 8 times		
AC over-current protection	E5	Blink 5 times		
Over compressor phase current protection	P5			Blink 15 times
Compressor loss step protection	H7			Blink 7 times
Compressor loss of phase protection	Ld			
IPM protection	H5			Blink 5 times
Low PN voltage protection	PL			Blink 21 times
Over voltage protection for PN	PH		Blink 11 times	
PFC protection	HC			Blink 6 times
4-way valve reversal abnormal	U7		Blink 20 times	
Mode conflict	E7	Blink 7 times		

## CHECKING UNITS PRIOR TO CONTACTING YOUR TECHNICIAN

### **⚠ WARNING**

Do not repair the air conditioner yourself. An Incorrect repair may cause electric shock or fire, so please contact an authorized service center for professional repair.

**Performing the following checks prior to contacting an authorized service technician may save you time and expense.**

Phenomenon	Normal or Abnormal
The unit doesn't deliver cooling or heating, immediately after the unit is restarted (remote control or power resuming).	If the unit is powered off, and then restored, it will not run the compressor until 3 minutes later. This is normal 3-minutes restarting protection due to high internal refrigerant pressure.
The unit emits a smell.	For a new unit, some of the odor is normal. For any bad or abnormal odor, shut off the unit and check the unit and the area around the unit for anything visible that could cause the odor. May need to call your technician.
Hearing the sound of "water flow" inside the unit.	Normally this is due to refrigerant flowing through the coils.
Mist is blowing out of the unit.	Normally this happens during cooling startup period, when the indoor air is hot and humid.
Hearing creaking noise during unit starting or shutting off.	Normally this is caused by the expansion or contraction of components due to temperature changes.
The unit doesn't operate at all.	<ol style="list-style-type: none"> <li>1) Is power shut off or lost?</li> <li>2) Is the TIMER set up?</li> <li>3) Is the circuit breaker engaged, or tripped?</li> <li>4) Is the fuse connected, or blown?</li> <li>5) Is the voltage too high or low?</li> <li>6) Is the flow control or other switches breaking the circuit?</li> <li>7) Is the unit under the 3-minute restarting protection period?</li> <li>8) Does the remote control have power?</li> </ol>
Unit doesn't respond to remote control.	<ol style="list-style-type: none"> <li>1) Does the remote control have battery power?</li> <li>2) Is the remote control pointing at sunshine or bright lights?</li> <li>3) Is the remote control signal blocked?</li> <li>4) Is the remote control too far away from indoor unit?</li> <li>5) Is the fuse on indoor unit blown?</li> <li>6) Is the indoor unit powered on?</li> <li>7) Is the indoor unit transformer good?</li> <li>8) Is the indoor unit control board good?</li> </ol>
Cooling (heating) is weak.	<ol style="list-style-type: none"> <li>1) Is the set temperature too high or too low?</li> <li>2) Is the filter dirty?</li> <li>3) Is the air vent blocked?</li> <li>4) Is the unit undersized?</li> <li>5) Is there a window or door opened?</li> <li>6) Is the unit refrigerant at a lower level?</li> <li>7) Is the outdoor temperature too hot or cold?</li> <li>8) Is fan speed set at a low speed?</li> </ol>
Indoor unit doesn't blow air.	<ol style="list-style-type: none"> <li>1) Is the unit in 3-minutes restarting protection period?</li> <li>2) In heating mode, the indoor fan motor will not rotate before the indoor coil is hot enough. This is a normal anti-cold air blowing function.</li> <li>3) Is the outdoor unit defrosting?</li> <li>4) Is the unit in fan-pausing period for dehumidification mode?</li> <li>5) Is the filter dirty?</li> <li>6) Is the fan motor setting screw loose?</li> <li>7) Is the fan capacitor bad?</li> <li>8) Is the fan motor bad?</li> </ol>



Phenomenon	Normal or Abnormal
Condensate forms at air discharge louver.	This is normal when the conditioned cool air is mixed with the warm/hot and humid indoor air. Condensate may go away gradually once the indoor air is dehumidified and cooled down.
Water drips out of the indoor unit.	<ol style="list-style-type: none"> <li>1) Is indoor air too warm and humid?</li> <li>2) Is the condensate drain hose/connection leaking?</li> <li>3) Is the condensate drain hose clogged or restricted?</li> <li>4) Is the condensate drain hose insulated?</li> <li>5) Is the 3" hole at exterior wall staffed or sealed?</li> </ol>
Noise is heard at the indoor unit.	<ol style="list-style-type: none"> <li>1) Is the fan motor or compressor relay energized?</li> <li>2) Is it due to temperature change that causes part expansion or contraction?</li> </ol>

**Stop all unit operations, disconnect power and contact your service technician in the following situations:**

1. Harsh sound is heard
2. Bad odor is detected;
3. Water is leaking out of the indoor unit;
4. Circuit breaker trips or fuse is blown a few times;
5. Wires or connections are very hot;
6. Oil or refrigerant leakage is found;
7. Unit vibrates abnormally;
8. Any other abnormal situations.

## R-T CONVERSION TABLE

### R25 : 15.0k Ω (Tolerance 1%)

Temp. (°F)	Resistance (kΩ)	Temp. (°F)	Resistance (kΩ)	Temp. (°F)	Resistance (kΩ)	Temp. (°F)	Resistance (kΩ)
-2.2	138.1	68	18.75	138.2	3.848	208.4	1.071
-0.4	128.6	69.8	17.93	140	3.711	210.2	1.039
1.4	121.6	71.6	17.14	141.8	3.579	212	1.009
3.2	115	73.4	16.39	143.6	3.454	213.8	0.98
5	108.7	75.2	15.68	145.4	3.333	215.6	0.952
6.8	102.9	77	15	147.2	3.217	217.4	0.925
8.6	97.4	78.8	14.36	149	3.105	219.2	0.898
10.4	92.22	80.6	13.74	150.8	2.998	221	0.873
12.2	87.35	82.4	13.16	152.6	2.896	222.8	0.848
14	82.75	84.2	12.6	154.4	2.797	224.6	0.825
15.8	78.43	86	12.07	156.2	2.702	226.4	0.802
17.6	74.35	87.8	11.57	158	2.611	228.2	0.779
19.4	70.5	89.6	11.09	159.8	2.523	230	0.758
21.2	66.88	91.4	10.63	161.6	2.439	231.8	0.737
23	63.46	93.2	10.2	163.4	2.358	233.6	0.717
24.8	60.23	95	9.779	165.2	2.28	235.4	0.697
26.6	57.18	96.8	9.382	167	2.206	237.2	0.678
28.4	54.31	98.6	9.003	168.8	2.133	239	0.66
30.2	51.59	100.4	8.642	170.6	2.064	241	0.642
32	49.02	102.2	8.297	172.4	1.997	242.8	0.625
33.8	46.6	104	7.967	174.2	1.933	244.6	0.608
35.6	44.31	105.8	7.653	176	1.871	246.4	0.592
37.4	42.14	107.6	7.352	177.8	1.811	248.2	0.577
39.2	40.09	109.4	7.065	179.6	1.754	250	0.561
41	38.15	111.2	6.791	181.4	1.699	251.8	0.547
42.8	36.32	113	6.529	183.2	1.645	253.6	0.532
44.6	34.58	114.8	6.278	185	1.594	255.4	0.519
46.4	32.94	116.6	6.038	186.8	1.544	257.2	0.505
48.2	31.38	118.4	5.809	188.6	1.497	259	0.492
50	29.9	120.2	5.589	190.4	1.451	260.8	0.48
51.8	28.51	122	5.379	192.2	1.408	262.6	0.467
53.6	27.18	123.8	5.197	194	1.363	264.4	0.456
55.4	25.92	125.6	4.986	195.8	1.322	266.2	0.444
57.2	24.73	127.4	4.802	197.6	1.282	268	0.433
59	23.6	129.2	4.625	199.4	1.244	269.8	0.422
60.8	22.53	131	4.456	201.2	1.207	271.6	0.412
62.6	21.51	132.8	4.294	203	1.171	273.4	0.401
64.4	20.54	134.6	4.139	204.8	1.136	275.2	0.391
66.2	19.63	136.4	3.99	206.6	1.103	277	0.382

## R-T CONVERSION TABLE

### R25 : 20.0k $\Omega$ (Tolerance 1%)

Temp. (°F)	Resistance (k $\Omega$ )	Temp. (°F)	Resistance (k $\Omega$ )	Temp. (°F)	Resistance (k $\Omega$ )	Temp. (°F)	Resistance (k $\Omega$ )
-2.2	181.4	68	25.01	138.2	5.13	208.4	1.427
-0.4	171.4	69.8	23.9	140	4.948	210.2	1.386
1.4	162.1	71.6	22.85	141.8	4.773	212	1.346
3.2	153.3	73.4	21.85	143.6	4.605	213.8	1.307
5	145	75.2	20.9	145.4	4.443	215.6	1.269
6.8	137.2	77	20	147.2	4.289	217.4	1.233
8.6	129.9	78.8	17.14	149	4.14	219.2	1.198
10.4	123	80.6	18.13	150.8	3.998	221	1.164
12.2	116.5	82.4	17.55	152.6	3.861	222.8	1.131
14	110.3	84.2	16.8	154.4	3.729	224.6	1.099
15.8	104.6	86	16.1	156.2	3.603	226.4	1.069
17.6	99.13	87.8	15.43	158	3.481	228.2	1.039
19.4	94	89.6	14.79	159.8	3.364	230	1.01
21.2	89.17	91.4	14.18	161.6	3.252	231.8	0.983
23	84.61	93.2	13.59	163.4	3.144	233.6	0.956
24.8	80.31	95	13.04	165.2	3.04	235.4	0.93
26.6	76.24	96.8	12.51	167	2.94	237.2	0.904
28.4	72.41	98.6	12	168.8	2.844	239	0.88
30.2	68.79	100.4	11.52	170.6	2.752	241	0.856
32	65.37	102.2	11.06	172.4	2.663	242.8	0.833
33.8	62.13	104	10.62	174.2	2.577	244.6	0.811
35.6	59.08	105.8	10.2	176	2.495	246.4	0.77
37.4	56.19	107.6	9.803	177.8	2.415	248.2	0.769
39.2	53.46	109.4	9.42	179.6	2.339	250	0.746
41	50.87	111.2	9.054	181.4	2.265	251.8	0.729
42.8	48.42	113	8.705	183.2	2.194	253.6	0.71
44.6	46.11	114.8	8.37	185	2.125	255.4	0.692
46.4	43.92	116.6	8.051	186.8	2.059	257.2	0.674
48.2	41.64	118.4	7.745	188.6	1.996	259	0.658
50	39.87	120.2	7.453	190.4	1.934	260.8	0.64
51.8	38.01	122	7.173	192.2	1.875	262.6	0.623
53.6	36.24	123.8	6.905	194	1.818	264.4	0.607
55.4	34.57	125.6	6.648	195.8	1.736	266.2	0.592
57.2	32.98	127.4	6.403	197.6	1.71	268	0.577
59	31.47	129.2	6.167	199.4	1.658	269.8	0.563
60.8	30.04	131	5.942	201.2	1.609	271.6	0.549
62.6	28.68	132.8	5.726	203	1.561	273.4	0.535
64.4	27.39	134.6	5.519	204.8	1.515	275.2	0.521
66.2	26.17	136.4	5.32	206.6	1.47	277	0.509

## R-T CONVERSION TABLE

### R25 : 50.0k $\Omega$ (Tolerance 1%)

Temp. (°F)	Resistance (k $\Omega$ )	Temp. (°F)	Resistance (k $\Omega$ )	Temp. (°F)	Resistance (k $\Omega$ )	Temp. (°F)	Resistance (k $\Omega$ )
-20.2	853.5	50	98	120.2	18.34	190.4	4.754
-18.4	799.8	51.8	93.42	122	17.65	192.2	4.609
-16.6	750	53.6	89.07	123.8	16.99	194	4.469
-14.8	703.8	55.4	84.95	125.6	16.36	195.8	4.334
-13	660.8	57.2	81.05	127.4	15.75	197.6	4.204
-11.2	620.8	59	77.35	129.2	15.17	199.4	4.079
-9.4	580.6	60.8	73.83	131	14.62	201.2	3.958
-7.6	548.9	62.6	70.5	132.8	14.09	203	3.841
-5.8	516.6	64.4	67.34	134.6	13.58	204.8	3.728
-4	486.5	66.2	64.33	136.4	13.09	206.6	3.619
-2.2	458.3	68	61.48	138.2	12.62	208.4	3.514
-0.4	432	69.8	58.77	140	12.17	210.2	3.413
1.4	407.4	71.6	56.19	141.8	11.74	212	3.315
3.2	384.5	73.4	53.74	143.6	11.32	213.8	3.22
5	362.9	75.2	51.41	145.4	10.93	215.6	3.129
6.8	342.8	77	49.19	147.2	10.54	217.4	3.04
8.6	323.9	78.8	47.08	149	10.18	219.2	2.955
10.4	306.2	80.6	45.07	150.8	9.827	221	2.872
12.2	289.6	82.4	43.16	152.6	9.489	222.8	2.792
14	274	84.2	41.34	154.4	9.165	224.6	2.715
15.8	259.3	86	39.61	156.2	8.854	226.4	2.64
17.6	245.6	87.8	37.96	158	8.555	228.2	2.568
19.4	232.6	89.6	36.38	159.8	8.268	230	2.498
21.2	220.5	91.4	34.88	161.6	7.991	231.8	2.431
23	209	93.2	33.45	163.4	7.726	233.6	2.365
24.8	198.3	95	32.09	165.2	7.47	235.4	2.302
26.6	199.1	96.8	30.79	167	7.224	237.2	2.241
28.4	178.5	98.6	29.54	168.8	6.998	239	2.182
30.2	169.5	100.4	28.36	170.6	6.761	241	2.124
32	161	102.2	27.23	172.4	6.542	242.8	2.069
33.8	153	104	26.15	174.2	6.331	244.6	2.015
35.6	145.4	105.8	25.11	176	6.129	246.4	1.963
37.4	138.3	107.6	24.13	177.8	5.933	248.2	1.912
39.2	131.5	109.4	23.19	179.6	5.746	250	1.863
41	125.1	111.2	22.29	181.4	5.565	251.8	1.816
42.8	119.1	113	21.43	183.2	5.39	253.6	1.77
44.6	113.4	114.8	20.6	185	5.222	255.4	1.725
46.4	108	116.6	19.81	186.8	5.06	257	1.682
48.2	102.8	118.4	19.06	188.6	4.904	259	1.64



# USER NOTES AND INSTALLATION/SERVICE/MAINTENANCE NOTES

## INSTALLATION NOTES

Please record any questions or problems you have experienced as a unit history:

No.	Date	Notes	Asked Your Technician for Help?	Asked YMGI Tech. contacted for help?





### USER NOTES

Please record any questions or problems you have experienced as a unit history:

No.	Date	Company Name, Technician Name, Phone & HVAC License #	Job Not Performed by Technician	Technician Checklist Completed Fully?









YMGI is dedicated to designing, manufacturing and distributing the highest quality, energy saving and environmentally friendly air conditioner and heat pump products, while providing the best service and support to all of our customers. Our mission is to help build a sustainable, efficient and green world.

### YMGI Symphony-Ductless & Ducted Heat Pump & Heat Recovery:

- **Symphony SOLAR DC Inverter**  
(56) Single PV, (79) Single PH 12-18K Btu/h  
(86) Single Zone All DC 09-24K Btu/h  
(55) Multi Zone Solar VRF 3, 4, 8, 16, and 24 Ton.
- **Symphony SOLO DC Inverter**  
(54) Series -22 °F Heat Pump and Universal Cabinet  
(57)2,3 Single Zone 16 SEER, 09-36K Btu/h  
(58)4, (78)1-Single Zone 18-23 SEER, 09-36K Btu/h
- **Symphony CHOIR DC Inverter**  
(46)2 DC Inverter Multiple Zone 15 SEER, 2x09K and 2x12K Btu/h  
(59)2S-DC Inverter Multiple Zone 16 SEER 6x09K to 9x09K Btu/h  
(59)4-DC Inverter Multiple Zone 21 SEER 2x09K to 5x12K Btu/h
- **Symphony VRF - DC Inverter HP, Heat Recovery, and Solar. Up to 64 zones.**  
(55)5 -4°F Heat Pump, Heat Recovery  
(55)5 -22°F Ultra Heating Heat Pump, Heat Recovery  
**Air Source and Water Source**
- **Symphony HARMONY-Packaged Self-Contained**  
42"x16" PTAC/PTHP Electric Heater or Hot Water Coil  
26"x16" TTWA  
VPAK
- **Symphony CONDUCTOR-Split Type Condensing Units**  
Side Discharge VRUO, YTAC & SHCR

601 Arrow Ln, O'Fallon, MO 63366  
www.YmgiGroup.com  
Tel: 866-833-3138 • Fax: 866-377-3355  
Email: info@YmgiGroup.com

Unit appearance and specifications are subject to change without notice.  
Copyright ©2021 YMGI Group

