



YMGI: Engineered Comfort Products for An Efficient and Sustainable Green World!

INSTALLATION INSTRUCTIONS & USER'S MANUAL

DC Inverter Multi Variable Refrigerant Flow (VRF) VRF Mini Slim Side-Discharge Outdoor Unit, Each 3, 4 & 5 Ton

For Model Numbers:

- VRFO-36HP-V2B(55)5
- VRFO-48HP-V2B(55)5
- VRFO-60HP-V2B(55)5



Thank you for choosing this YMGI product. Please read the user's manual carefully before installation/operation and retain for your records and future reference. If you need a replacement copy, please contact your local agent or visit www.ymgigroup.com to download a current electronic version.

NOTICE

This product is designed and manufactured to be free from any defects in material and workmanship during normal use and maintenance. Installation, operation, maintenance and repairs must follow all standards and professional practices for regular cooling and heating equipment, such as NEC, State, or Local Codes and all related documents/manuals provided by YMGI. Failure to follow and adhere to all codes and documentation can cause damage to equipment, property or even personal injury.

Installer: Must be currently licensed/certified HVAC technicians only. Must Read the manual and all provided documents prior to installation. Complete and fill out all required information on the **Warranty Registration Card**.

User: Retain this manual and all supplied documents for your records and future reference.

Servicer: Use this manual for information concerning servicing and maintenance of this product.

SAFETY WARNING

Only qualified technicians should install and service this equipment. The installation, startup, operation and servicing of this equipment can be hazardous and requires a HVAC professional who has been trained, licensed and certified. Installations, adjustments or any equipment alterations done by an unqualified person could result in serious injury and even death. When working on the equipment, observe all precautions in the provided documents, on the tags, stickers, and labels that are attached to or placed on the equipment.

TABLE OF CONTENTS

Introduction	3
Note From YMGI – Must Read	5
Installing Technician/Contractor's Responsibilities	7
Limited Product Warranty	8
Limited Product Warranty Registration Card	10
Why Does YMGI Group Require Installation and Service to Be Performed 100% By Currently Licensed or Certified HVAC Technicians/Contractors	11
Suggestions to Aid You in Hiring an HVAC Contractor	11
Safety Precautions	12
Product Information.....	13
Preparation Before Installation	14
Installation Site	15
Installation Instructions	16
Dimensions of Outdoor Unit	16
Connection Pipe.....	17
Selection of Indoor Branches	18
Installation of Connection Pipe	23
Installation of Y-Type Branch	26
Vacuum System and Adding Refrigerant	29
System Wiring	31
Check Items After Installation	34
Test Operation and Debugging	35
Troubleshooting	39
Maintenance and Care	48
User Notes and Installation/Service/Maintenance Notes	50

Introduction

Read this manual carefully, making sure you understand all the instructions, practices and procedures contained in this manual. Be sure you are familiar with all the safety advisories that appear throughout this manual. Your personal safety depends upon your observance of all precautions contained in this manual.

The 3 types of advisories are defined in the following table:

⚠ WARNING	Indicates a potentially hazardous situation which, if not avoided, could result in serious injury or even death.
⚠ CAUTION	Indicates a potentially hazardous situation which, if not avoided, could result in minor or moderate injury. It is also used to alert against unsafe practices.
NOTICE	Indicates a situation that could result in equipment or property-damage only. It can also be used to call attention to important details within this manual.

Important Environmental Concerns

Studies have shown that certain man-made chemicals can affect the earth's stratospheric ozone layer when released into the atmosphere. Refrigerants that contain Chlorine, Fluorine and Carbon (CFCs) and those containing Hydrogen, Chlorine, Fluorine and Carbon (HCFCs), may affect the ozone layer. Not all refrigerants have the same potential impact on the environment. YMG I Group advocates for the responsible handling of all refrigerants including industry replacements for CFCs such as HCFCs and HFCs.

Responsible Refrigerant Practices

YMG I Group believes that responsible refrigerant practices are important to our customers, the HVAC/R industry and the environment. All HVAC/R technicians who handle refrigerants must be certified. The Federal Clean Air Act (Section 608) sets forth the requirements for handling, reclaiming, recovering and recycling of certain refrigerants, the equipment and tools necessary to perform these service procedures. In addition, some states or municipalities may have additional requirements that must also be adhered to for responsible management of refrigerants. HVAC/R technicians must know the applicable laws and follow them.

Disposal Notice

Do not dispose of this product or its components as unsorted municipal waste, as they contain items that may require special treatment. Contact your local waste management company for details.

⚠ WARNING

Proper Field Wiring and Grounding Required!

Failure to follow established electrical codes can result in death, serious personal injury and property damage. All field wiring **MUST** be performed by qualified personnel, such as a currently licensed electrician. Improperly installed and grounded field wiring poses **FIRE** and **ELECTROCUTION** hazards. To avoid these hazards, you **MUST** follow the requirements for field wiring installation and grounding as described in this manual, by NEC and your state/local electrical codes.

⚠ WARNING

Personal Protective Equipment (PPE) Required!

Failure to wear proper PPE for the job being undertaken could result in serious injury or even death. Technicians must take the necessary precautions to protect themselves from potential electrical, mechanical, and chemical hazards and **MUST** follow all precautions in this manual and on the tags, stickers, and labels, as well as the instructions below:

- Before installing or servicing this unit, technicians **MUST** put on all PPE recommended for the work being undertaken. **ALWAYS** refer to appropriate Material Safety Data Sheets (MSDS) and Occupational Safety and Health Administration (OSHA) guidelines for proper PPE.
- When working with or around hazardous chemicals, **ALWAYS** refer to the appropriate MSDS sheets and OSHA guidelines for information on allowable personal exposure levels, proper respiratory protection, and handling recommendations. If there is a risk of arc or flash, technicians **MUST** put on all PPE in accordance with NFPA 70E or other country-specific requirements for arc flash protection, **PRIOR** to servicing the unit.

Copyright

This document and the information contained therein are the sole property of YMGI Group and shall not be used or reproduced in whole or in part, without the written permission of YMGI Group. YMGI Group reserves the right to revise this manual at any time and to make changes to its content without obligation to notify anyone about any modifications, revisions or changes.

⚠ WARNING

- Instructions for installation and use of this product are provided by the manufacturer.
- Installation must be performed by authorized and licensed personnel only and in accordance with all the requirements of this manual, the NEC, CEC and any state/local codes.
- For safe operation of this unit, please read and follow all instructions carefully.
- The total operation capacity of the indoor units should not exceed 120% of the total capacity of the outdoor units if all indoor units must operate at their peak capacities all the time. Otherwise, the heating and cooling operation will be diminished and less efficient which could damage the units.
- Any person responsible for system operation or system maintenance should retain this manual for reference.
- If the unit fails to operate normally, please contact your authorized system installer or HVAC professional as soon as possible and provide the following information:
 - Data on the unit (model number, serial number and owner's name).
 - A detailed description of the unit's problem before and after the problem occurred.
- To avoid personal injury or property damage, do not disassemble the unit yourself. If disassembly is required to check the unit, contact your authorized system installer or HVAC professional as they have the experience and training necessary to perform this task.

Note: Each unit has been thoroughly tested to ensure it operates correctly before leaving the factory.

Basic Cautions and Warnings

⚠ CAUTION

All units shall be installed by an experienced HVAC licensed contractor or technician. Read all manuals before installation, startup and operation.

⚠ CAUTION

All NEC, state, local codes and installation instructions must be followed for all units, otherwise, the unit warranty will be void and could result in serious damage to people or property.

⚠ WARNING

YMGI Group is not responsible for any damage or loss due to Do-It-Yourself (DIY), self-installation or any improper installation, operation, service or natural disasters of any kind.

⚠ WARNING

Do not connect power to the unit until all wiring, tubing and all unit inspections and tests have been completed. Ground the unit according to the instructions and adhering to NEC, state and local codes.

⚠ WARNING

All wiring connections must be correct and secure. Loose wire(s) or improper contacts may cause arcs or overheating which can result in a fire hazard.

Note From YMGI – **Must Read**

Dear Customers, Installers, and Contractors

Thank you for choosing a YMGI product.

All YMGI's products are fully tested and have passed rigorous safety, performance and manufacturing standards before being packed and shipped. YMGI only uses suppliers that meet our strict standards for high quality and performance for all parts. YMGI also recognizes a quality installation is equally important therefore your system must be installed by a licensed HVAC professional. A quality installation ensures your unit will operate at its highest efficiency and peak performance for many years of worry free comfort; while a poor installation can result in unit failure and cause the unit to operate inefficiently, either immediately or over time, resulting in costly repairs.

Because a quality installation is so critical, YMGI provides detailed information in our manuals which will aid the installing technician and the owner of the unit(s).

At YMGI our goal is to ensure that your YMGI units are installed properly and correctly from the beginning.

The YMGI equipment you purchased is either a split-type or a self-contained cooling/heating system. These types of systems require a certified and licensed HVAC professional technician for proper installation. Only a certified and licensed HVAC professional technician will have the knowledge, experience, and attention for all required details to perform a complete and successful installation. This equipment is different from a window or portable type air conditioners you can purchase from local big box and retail stores which the manufacturer may not require certified and licensed personnel to install.

Reading and following YMGI Group recommendations and requirements contained in the following pages and other documents, is the first step to help ensure a smooth installation and proper operation of your unit for many years.

⚠WARNING

YMGI does not recommend nor allow any Do-It-Yourself (DIY) installation (partially or fully). Due to the complexity of the installation of this product most DIY installations usually have problems, either immediate or in the near future. These problems can cost more to fix than any upfront savings. **YMGI warranty does not cover any DIY units.**

If you have any questions about your unit or if the unit has a problem, you should first check the manual. If you can't find a solution, then contact your local installer or service technician to schedule a service appointment. The technician can physically inspect the unit. If at the time of inspection, the installer or service technician has any questions about the unit, they can contact YMGI technical support division directly at:

Toll Free Number: (866)833-3138 or Email: techsp@ymgigroup.com

IMPORTANT: YMGI Group is the MEDIA AUTHORITY:

YMGI Group, located in O'Fallon, MO 63366 is the author of all media produced for its products and is the only party able to give any additional explanation for any data, definitions and or descriptions found within any of its media, including but not limited to YMGI product brochures, manuals, pamphlets, catalogs, and videos. YMGI's distributors, installers, dealers, agents, customers or any other third parties will not supersede YMGI in anyway concerning YMGI published materials and their meaning. Any concerns or questions arising from YMGI distributors, installers, dealers, agents, customers or any other third parties, should be presented directly to YMGI. YMGI will respond to any concerns or questions, if necessary, about any of its media in writing.



NOTICE

- Be sure to only hire a certified and currently licensed HVAC Company to complete 100% of the installation so that all details of the installation are performed correctly and completely.
- Factory Warranty will be void if any portion of the installation is not performed by a licensed HVAC contractor/technician. DIY or partial DIY will also void ALL factory warranties.
- Hiring an HVAC technician that is offering their services as a "side job" rather than a licensed HVAC company may pose possible risk. This may result in an incomplete or unsatisfactory installation, no guarantee for workmanship, maintenance or further service to your unit.
- Have the installation technician read in full the installation manual and all supplied documents for the product model you purchased. Details within the provided documentation contributes greatly to the success and quality of the installation. Experience with other manufacturers may not be applied fully to another manufacturer, although there will be similarities there will also be differences. Ignoring the provided installation procedures is an act of negligence and may cause unit failure or damage which could be permanent.
- It is possible for a licensed contractor/technician to make a mistake during the installation. YMGI does not supervise nor is able to control the contractor/technician's installation. It is critical that the installer take each variable into account during the initial installation. This will ensure a complete and professional installation and that all units work properly.

⚠WARNING

The following will damage the unit and its key components resulting in loss of factory warranty:

1. Any foreign substances introduced into the system because of failure to seal the ends of the refrigeration piping before pulling the piping through any structures at time of installation.
2. Not installing an oil P-trap in the copper suction line where the indoor unit is located 18 feet or more below the outdoor unit.
3. Cross piping and/or cross wiring of any units including more than one single zone or a multi zone system.
4. Not conducting a positive leak check prior to the negative leak check.
5. Not conducting a positive leak check by charging the system with dry-nitrogen 350 PSI to hold for 3+ hours, and performing soap bubble testing.
6. Not conducting a negative leak check by evacuating the copper lines for 30 minutes for each zone. Vacuum must be held at 500 microns or better for at least 60 minutes, starting 60-minute timer after the vacuum pump is turned off.
7. Not selecting the correct size of wire or circuit breaker.
8. Not answering ALL questions in the technician's checklist located inside the warranty registration form.

⚠WARNING

The following may be overlooked, ignored, or considered unimportant during your installer's installation, but will cause your unit to underperform and may cause unit failure.

1. Any kinks in or improper bending of the copper piping.
2. Any poorly formed flares, not centering the flare with the flare nut, or not tightening all connections.
3. Not testing each indoor unit individually.
4. Not reading technical data (temp/time/pressure/current) after the system is stabilized (normally the compressor needs to run at least 10 minutes before reading the data). If the data is read too early, it may lead to inaccurate assessments about the unit.

In an effort to help protect our customers from possible faulty installations that can lead to premature unit failure, YMGI provides the above information for you (the owner) and the technician. You can observe while your system is being installed, even though your observation is not a guarantee your system is being or has been installed properly and professionally. With the information provided above, you will know some things to look for and questions you can ask. If at any time you feel there may be an issue with the installation, please have your technician contact YMGI at (866)833-3138 x 703 with any questions, issues or concerns you may have.

INSTALLING TECHNICIAN/CONTRACTOR'S RESPONSIBILITIES

1. Discuss with the customer detailed information about the structure to be conditioned, local weather (typical design, extreme temperature/humidity conditions, cooling and heating hours), previous and existing HVAC equipment (if any), usage and dependence on new HVAC equipment or YMGI products.
2. Performing a cooling/heating load calculation by using commercially available professional programs/methods such as Right-J (Manual J) for residential HVAC applications and Right-CommLoad (ASHRAE RTS/CLTD) for light commercial and commercial HVAC applications.
3. Contact your YMGI distributor/sales department or contact YMGI directly to obtain additional information to fully understand your YMGI products, including but not limited to product features, cooling/heating performance at standard ratings/conditions and extreme conditions, allowed indoor and outdoor temperature and humidity ranges, installation, operation, maintenance, service, warranty, parts and any other issues pertaining to YMGI products.
4. Select the correct (most suitable) YMGI product unit models and accessories necessary for your HVAC applications and list them in the proposal/quote, in writing, on company's quotation form or letter head, based upon the information you collected from 1, 2 and 3 listed above.
5. List your currently valid HVAC license number and EPA number in your proposal/quote.
6. Make sure you are the only party to perform the entire installation and you will not sub-contract any part of the installation to any unlicensed parties or persons. You will be solely responsible for the entire installation that you have been contracted.
7. Make sure you have all the materials you need to properly, completely and correctly finish the installation. The YMGI units and accessories may be just a portion of what you will need for the project. When support issues arise, remember YMGI employees and YMGI distributors/sales, dealers and agents are not installers and may only provide suggestions. You are the only one qualified to determine what other materials you need to complete the installation.
8. When connecting electrical wires, follow all NEC, state and local codes and ensure the installation of all YMGI units and accessories meet these requirements.
9. Connect the unit to a correctly sized electrical power source. If the unit is installed in an area where lightning or storms occur frequently, a correctly sized and type of power surge protector must be installed between the outdoor unit and the power source.
10. Select the correct types and sizes of HVAC circuit breakers, disconnect switch boxes, wires and conduit from circuit breaker to disconnect box and then from disconnect box to outdoor unit.
11. Select the proper location for installing indoor units and outdoor units with all factory requirements being followed (cooling/heating air inlets and outlets are not blocked, or restricted, mounting structure is secure, installation for convenience is considered, allow adequate clearance for maintenance/service and all applicable codes are met).
12. Cap/tape the two ends of every copper line before running them through any structure to keep any foreign substances from entering the copper line causing contamination. Label the copper lines A-A, B-B, C-C, D-D, or any other identifying marks on each pair of copper lines and wiring cable sets to keep from cross-piping or cross-wiring in multiple zone installations or where pipes for different single zone systems are close to one another.
13. Secure the wiring cables that connect between the indoor unit and outdoor unit, following all applicable NEC, state and local codes for your installation. If there are no special NEC, state or local codes to govern how these wires are to be installed, you can tape/cable tie them along with insulated copper line.
14. Tighten all pipe and wire connections ensuring there is no leakage or false/loose connections.
15. Conduct a positive pressure leakage test, checking each of the inter-connecting copper lines between each indoor unit and outdoor unit by charging with dry-nitrogen at the outdoor unit's service port (**NOTE: do not back-seat stopping valve**). A liquid soap solution shall be applied at all pipe connections to check for leakage. A 1/4" - 5/16" hose/valve adaptor may be needed if you have a 1/4" traditional manifold hose connection.
16. If there is no positive leaking, then conduct a negative pressure leakage test, checking all inter-connecting copper lines between each indoor unit and outdoor unit by pulling vacuum at the outdoor unit's service port (**NOTE: do not back-seat stopping valve**) and checking that a vacuum level of 500 Microns can be held for at least 20 minutes.
17. If there is no leakage found at any of the refrigeration pipe connections, flip up the indoor unit's face panel and remove its filter, carefully pour some clear water onto the up-right aluminum coil surface to test if the water can drain freely out of each of the indoor unit's without finding any leakage.
18. If there is water leakage found, locate the source of the leak and correct it. Only after everything is clear and all the necessary inspections made, engage the correct electrical power to the system.
19. Then back-seat stopping valves of the outdoor unit to release refrigerant from the outdoor unit into the inter-connecting pipes and the indoor unit.
20. Make sure both the indoor unit and outdoor unit are powered on correctly, operating the indoor unit in fan mode first. Then move on to test cooling, dehumidifying/drying, heating and other modes.
21. Read refrigerant pressures and pipe/valve temperatures only after the system is stabilized (normally 10 minutes after cooling/heating mode is started successfully). Record this data into the technician checklist in the lower half section of the Limited Product Warranty Registration Card/Form.
22. Adjust refrigerant charging level (remove refrigerant if pipe is shorter, the temperature is colder; add refrigerant if pipe is longer the temperature is warmer), following the manufacturer's instructions. If the average pipe length is shorter or longer than 25' and pressure/temperature readings at the outdoor unit service valves are not falling into normal ranges.
23. Explain to the user/owner about proper unit operation and maintenance. Leave your contact information to allow them to reach you. If the customer finds the unit does not work properly and cannot resolve the issue themselves, check the customer's units/parts/accessories and correct the issue if there is one. Communicate with YMGI-technical support line at (866)833-3138 x 703, if further help is necessary.

Following these requirements will aid in ensuring that the units to be installed meet general HVAC practicing standards and necessary factory requirements. Finding any possible problems early and preventing any further damage to the unit will help to ensure a properly working unit for many years.



LIMITED PRODUCT WARRANTY

Once the installation and successful testing of the system has been completely performed by a qualified licensed/certified HVAC technician/contractor, the registration card/form is filled out completely and correctly, mailed and filed along with a valid installation invoice from the contractor within 7 days of the original installation, the following standard **Limited Product Warranty** is qualified: **10-years** on the **compressor** and **5-year** on **PARTS ONLY**. There is **no labor coverage**.

YMGI products are designed and manufactured free from defects in workmanship, and materials for normal use. However, if for any reason, including occasionally transporting between YMGI factories/warehouses and your delivery location, you discover the unit has issues, YMGI Group will help field a solution by following YMGI's established warranty procedures:

Compressor: YMGI will warrant the compressor of a YMGI-validated and approved warranty filing, for a period of 10 years from the date of successful installation at its original installation location.

Parts: YMGI will warrant parts of a YMGI-validated and approved warranty filing, for 5 years from the date of successful installation at original installation location.

All warranty compressors and parts replaced will become the sole property of YMGI Group and must be returned upon request. Warranty parts may be new or refurbished. All parts are tested and approved before shipping. **At no time does YMGI Group warrant labor cost of any type. Warranty will start from the date of a successful installation at the original installation location, or 90 days as of original shipping date from YMGI Group, whichever comes first.**

This is a standard limited liability warranty and DOES NOT cover the following:

- Any damage or repairs to properties, or persons as an incident of or consequence of improper faulty transportation, installation, operation, maintenance or service.
- Any damage caused by frozen or broken water hoses or refrigeration pipes in the event of equipment failure.
- Any damage due to floods, fire, wind, lightening, accidents, corrosive atmosphere.
- Any damage due to interruption or inadequate electrical service to equipment.
- Any products that are installed outside the US or Canada.
- Any unit that has been moved from its original installation address.
- Any labor costs associated with the installation or service of the unit.
- Poor unit performance due to improper unit selection (SEER, Unit size).

To validate the above warranties, ALL of the following conditions must all be fulfilled:

1. The unit was fully (100%) and successfully installed by a licensed or certified HVAC technician.
2. The unit was installed following all NEC, state and local codes.
3. The unit was installed following all the information within the Instructions and User Manuals provided by YMGI Group.
4. ALL fields, especially the technician-checklist, of the **Limited Warranty Registration Card/Form** were filled out completely by the installing technician and signed by both the installing company's technician and the unit owner.
5. The **Limited Warranty Registration Card/Form** and a copy of the original installing company's invoice have been received by YMGI Group-Warranty Dept., POB 1559, O'Fallon, MO 63366, within 7 days of successful installation.

**No warranty filing will be validated or approved, if any one of the above conditions are not met.
Product registration does not guarantee the validity of this limited warranty statement.**



Steps to follow for warranty part replacement:

1. The installing or service technician must contact YMGI tech support at 1-866-833-3138 ext. 703 from the installation location to check and confirm with YMGI Technical support the exact part(s) needed to fix the problem(s).
2. YMGI will check the customer's warranty filing. There will be no charge for Parts with a validated and approved warranty. Any Parts needed for warranties that have not been validated and approved or have an invalid warranty filing (resulting in an unapproved warranty request), will be charged accordingly.
3. YMGI will ground ship the parts ASAP. Expedited shipping is available at the customer's expense.
4. Replacement parts that have an approved warranty registration are to be warranted for the remainder of the 5 year on parts and a 10-year compressor warranty. Purchasing of replacement parts without a valid warranty filing or unapproved warranty request, will be sold as is and are not covered by any warranty.

YMGI is continually improving products with various engineering changes and these changes are made without prior notice. Such improvements or changes include but are not limited to product specification, appearance, functionality, size, packaging, etc. These improvements or changes will not void the limited warranty stated herein. YMGI is the final authority concerning this warranty policy.



YMGI GROUP
Innovative, Competitive, Efficient & Convenient

LIMITED PRODUCT WARRANTY REGISTRATION CARD / FORM

YMGI to Fill Top Portion, at Shipping, and Keep Copy A; Center Copy B for Installer to Fill and Mail back to YMGI; Bottom Copy C for Customer to Fill and Keep

For YMGI Use Only	The Company the Unit Was Sold Through: _____	Shipping Packing List Number: _____	Registration Card Serial No. _____
	Did the Company Pay to YMGI: _____	HVAC Contractor/ Technician-Name _____	Date the Filled Registration Card YMGI Received: _____
	Installation Invoice Attached to the Registration Card _____	Hired YMGI-Recommended HVAC Contractor/Technician? _____	Unit(s) Work Successfully (Yes/No): _____
Outdoor Serial Number (One Outdoor Unit, One Registration Card/Form): _____	Indoor Serial Number: _____	For Multi-Zone Units _____	Unit #1 _____ Unit #5 _____ Unit #2 _____ Unit #6 _____ Unit #3 _____ Unit #7 _____ Unit #4 _____ Unit #8 _____

Contact Where the Units are Installed:
 Name: _____ Phone: _____ Fax: _____
 Address: _____ Email: _____
 City: _____ State (Province): _____ Country: _____

Contact of the Installing HVAC Contractor/Technician: Technician Full Name (Print): _____ HVAC Technician's Company Name: _____ Address: _____ Currently Licensed or Certified HVAC Technician License or Certification Number: _____ License Approved or Certified by: _____ Official Phone # to Check the License Validity: _____	YMGI-Recommended Contractor/Technician: Phone: _____ Fax: _____ Email: _____ City: State (Province): _____ License Approved or Certified by: _____
---	---

List for Installing HVAC Technician to Double Check Installation Quality, and Warranty Processing Purpose (if not filled by technician, or not filled fully, warranty will void)

- | | |
|---|---|
| 1) Are you the only one to install whole system?
If not, _____ % of installation done by you (HVAC technician). | 2) What had been done, prior to your arrival? |
| 3) Did you read the User Manual and Installation Instruction, before you started the installation? | 4) Who unpacked the unit and accessory boxes to check for damage? |
| 5) Supply electrical power V/Ph/Hz measured at wiring terminal block of
Indoor unit: _____ outdoor unit: _____ | 6) Incoming electrical power V/Ph/Hz measured at terminal blocks of
indoor unit: _____ outdoor unit: _____ |
| 7) Wire gauge, length and terminal colors between circuit breaker/
disconnect switch to outdoor unit: | 8) Wire gauge, length and terminal colors between each indoor and
outdoor unit: Unit A _____ Unit B _____ Unit C _____ Unit D... |
| 9) The size of HVAC circuit breaker/fuse or disconnect switch to the
outdoor unit: | 10) Are the inter-connecting wires and copper lines between indoor and outdoor
units installed/covered/protected by line set covers, or anything else? |
| 11) What is the refrigerant pipe length between each indoor unit and the
outdoor unit? Unit A _____ Unit B _____ Unit C _____ Unit D... | 12) Where is/are the indoor unit(s) located?
Unit A _____ Unit B _____ Unit C _____ Unit D... |
| 13) What is the elevation difference between each indoor unit and the
outdoor unit? Unit A _____ Unit B _____ Unit C _____ Unit D...
(indoor unit above outdoor unit +, below -) | 14) Did you check the indoor unit for condensate leakage and refrigerant
leakage, before and after connecting them? |
| 15) Where is the outdoor unit located? Is the outdoor unit anchored to
ground wall balcony roof other _____ bracket? | 16) Have you checked to make sure there is no cross-piping and no
cross-wiring between any two indoor units (zones)? How did you do it,
who was with you? |
| 17) Were the refrigerant pipe ends capped or taped seal, prior to running
them through structures to keep debris from entering the copper lines? | 18) Have you checked and run cooling or heating, one unit by one unit, all
working fine? |
| 19) Did you charge the inter-connection copper pipes and indoor unit with
nitrogen to check for positive leakage (pressures 150-200PSI), before
conducting vacuuming leakage check? | 20) Did you vacuum correctly to check the connecting pipes and indoor unit for
leakage, what was the micron gauge reading, for how many minutes? |
| 21) Did you check if the compressor can be started and stopped in a
correct (design) manner? | 22) If copper length were not made to the supplied or recommended
refrigerant pipe length, how much refrigerant added or deducted? |
| 23) Measured refrigerant pressures at outdoor service suction valve, when unit
was st.
Heat pump (PSI): _____ Cooling (PSI): _____ Outdoor Ambient Temp. (°F): _____ | 24) What were the measured temperatures (probe not touching any metal):
At cooling: indoor return air _____ °F, discharge air _____ °F, and outdoor _____ °F
At heating: indoor return air _____ °F, discharge air _____ °F, and outdoor _____ °F |
| 25) Have you checked all unit functions, with customer's witness, and all
functions are correct? | 26) Did you show the user how to operate the unit? Did he/she understand you? |
| 27) Do you provide regular one-year free technical service for this
installation? | 28) Do you list the working details in the invoice and leave a copy to the
customer? |

Installation Finished and Unit Works Successfully. Print Name of Installation HVAC Technician: Signature: _____ Date and time: _____	Installation Finished and Unit Works Successfully. Print Name of Owner: Signature: _____ Date and time: _____
---	--

By signing above, I acknowledge the liability and responsibility for any false statement or not telling all the facts, and I authorize YMGI to check the details of the filled above, and make its decision on warranty. I understand our filing or filling the warranty card/form DOESN'T mean automatic warranty approval, because warranty is approved only to those qualified and successful installations by qualified HVAC technician. I know the warranty, if approved, is a standard 5-year compressor and 1-year other parts only, without any labor coverage. I agree to and will follow all the contents contained in the Limited Product Warranty Policy that YMGI, not other entity, stated in public, including but not limited to manuals, web site, email, etc.

Important Note: A copy of the installing HVAC company's invoice to show all their work details, your payment proof, center copy B of this registration card filled after a successful installation, all three (3) MUST be mailed together to Warranty Dept., **YMGI Group, POB 1559, O'Fallon, MO 63366**, for warranty processing. Customer keeps bottom copy C. YMGI will check against copy A that was kept at YMGI.



WHY DOES YMGI GROUP REQUIRE INSTALLATION AND SERVICE TO BE PERFORMED 100% BY CURRENTLY LICENSED OR CERTIFIED HVAC TECHNICIANS/CONTRACTORS?

1. Expertise and Safety:

They have the training and experience to accurately and safely install and service your equipment. The equipment runs with high-pressure refrigerant, oil and electrical current. The copper lines must be installed properly to prevent leakage and foreign substances from contaminating the refrigerant system.

2. You will save money in the long run:

If any problem occurs with the unit that has been fully installed by a currently licensed or certified technician/contractor, contact the original licensed or certified HVAC technician to evaluate the unit as they have the training and experience to correct the problem quickly and efficiently. A technician may be unwilling to repair an issue on a unit that they did not install. If you do find a technician willing to perform this service, there is an increased possibility of higher service fees, increased service visits, or delayed service from that technician.

3. It's the law!

The federal, state and/or local government and authorities have various governing laws or regulations, guidelines, ordinances, etc. These laws may require only licensed or certified professionals can install and service this type of high pressure HVAC equipment.

SUGGESTIONS TO AID YOU IN HIRING AN HVAC CONTRACTOR:

1. Hire a currently practicing, licensed/certified HVAC professional technician/contractor. Technicians, who are no longer practicing (retired, etc.) in this field, may not have current technical knowledge or may lack experience on the equipment you have purchased.
2. Hiring a licensed technician to install your unit as a "side job" rather than a licensed HVAC company may pose possible risk. This may result in an incomplete or unsatisfactory installation, no guarantee for workmanship and lack of maintenance and further service to your unit.
3. Hire a technician/contractor who services customers in your local area and one you are familiar with. Local contractors have a faster response time and it will be easier for you to determine if they are reputable.
4. Use only a reputable licensed/certified HVAC installation professional to prevent any unexpected charges because of unethical business practices.
5. Check their references, verify they provide professional service for their customers. N.A.T.E or A.C.C.A certified technicians are strongly recommended.
6. Some contractors/technicians may not feel comfortable installing equipment that has been purchased by someone other than themselves. You can contact YMGI directly to check and see if there are contractors in your area who have installed our products or any similar products.
7. Ask for a detailed quote for the complete installation project. A flat rate quote is the safest contract for both you and the contractor.
8. Local HVAC technicians may charge you on a project basis or on an hourly basis. It has been our general experience; **a full single head installation normally can cost \$800 to \$1500**. These costs are estimates, and your actual costs may differ due to your specific job requirements and installation location.
9. Number of hours can vary depending upon each individual situation, some factors are, but not limited to:
 - Difficulty or complexity of securely installing the indoor unit.
 - Difficulty or length of the inter-connecting pipes and wires to be installed.
10. A successful installation is dependent on all these suggestions and necessary steps are followed.
11. If the contractor(s)/technician(s) are experienced with the systems/brands you purchased. **You might save on the installation cost but remember to always ask for and verify references.**
12. The contracts should list and detail all work to be performed and the standards they will follow. Some contractors are willing to include a 1-year installation/service warranty at no extra charge. Check to see if this is an available option. If available, make sure it is included in the contract.
13. Verify and confirm the installation is completed and all the unit functions have been tested and working properly. All items on the checklist should be checked and clearly marked in the warranty registration card/form, prior to paying the contractor in full.

The cost of not having your unit professionally installed can be more expensive than the additional cost of hiring a certified contractor. Protect your investment and warranty eligibility by doing it right the first time.

⚠WARNING

Safety Precautions

1. Follow these instructions to complete the necessary installation progress. Carefully read this manual before installation and unit startup or servicing.
2. Wire size of power cord should be properly sized to meet the required electrical loads. Should the power cord get damaged, the power cord should be replaced with a manufacturer approved cable.
3. After connecting the power cord, attach the electric box cover and secure properly.
4. Always meet the nitrogen charge requirements when welding pipes.
5. Never short-circuit or cancel the pressure switch as this will result in damage to the unit.
6. Connect the wired controller before energizing, otherwise the wired controller cannot be used.
7. Before using the unit, verify the piping and wiring are correct. This will avoid water leakage, refrigerant leakage, electric shock, fire, etc.
8. Do not insert fingers or objects into the air outlet or inlet grille.
9. Open a door or window for ventilation for allowing fresh air to enter the room to avoid depleting the oxygen while gas/oil supplied heating equipment is used during the installation.
10. Never start up or shut off the unit by means of directly plugging into or unplugging the power cord from the power outlet.
11. Turn off the unit after it runs at least five minutes, otherwise it will influence the oil return of the compressor.
12. Do not allow children to operate this unit.
13. Do not operate this unit with wet hands.
14. Turn off the unit or disconnect the power supply before cleaning the unit. This will avoid possible electric shock or personnel injury.
15. Never spray or splash water towards the unit. This can cause a malfunction in the unit or can result in electric shock.
16. Do not expose the unit to moist or corrosive environments.
17. While operating in cooling mode, do not set the indoor unit room temperature too low. Keeping the temperature difference between indoor and outdoor unit within 41°F (5°C).
18. YMGI Group recommends that only properly trained and authorized personnel be allowed to repair or service the unit. Improper repairs or servicing can result in electric shock or fire hazards. Please contact YMGI Group if you need help locating a qualified repair or service technician.
19. Before installation, check the power supply to ensure it is sufficient to meet and is in accordance with the requirements specified on the nameplate of the unit. Ensure the power overload is functioning correctly and make sure it is properly maintained.
20. Installation must be performed only by an authorized installer or HVAC professional in accordance with the requirements set by the NEC and CEC. Do not attempt to install the unit yourself. Improper handling may result in water leakage, electric shock, fire, and voiding of the warranty.
21. Be sure to use only approved accessories and parts to prevent water leakage, electric shock and fire.
22. Make sure the unit is grounded properly prior to connecting to power source, to avoid electric shock. Do not connect the ground wire to a gas pipe, water pipe, lightning rod or telephone line.
23. Energize the unit for 8 hours before operation. Turn off or disconnect the power within 24 hours to prevent shortcycling (to protect the compressor).
24. If refrigerant leakage happens in a confined space during installation, ventilate immediately. Poisonous gases can occur if the refrigerant gas is exposed to fire.
25. Volatile liquids, (such as paint thinners or solvents) if exposed to the unit's surface will damage to the surface finish. Only use a soft cloth along with a mild non-abrasive detergent to clean the outer casing of the unit.
26. If the unit does not operate normally or if you notice any type of burning odor, power off the unit and turn off the main power supply, then immediately contact your YMGI authorized repair service center or HVAC professional.

Product Information

YMGI Multi VRF System adopts inverter compressor technology. By changing the displacement of the compressor, stepless capacity regulation within range of 15%~100% can be realized. Various product lineups are provided with capacity range from 36000Btu/h to 60000Btu/h, which can be widely used in residential, commercial and working area and especially applicable to places with big load change. YMGI's residential air conditioner is absolutely your best choice.

Names of Main Parts

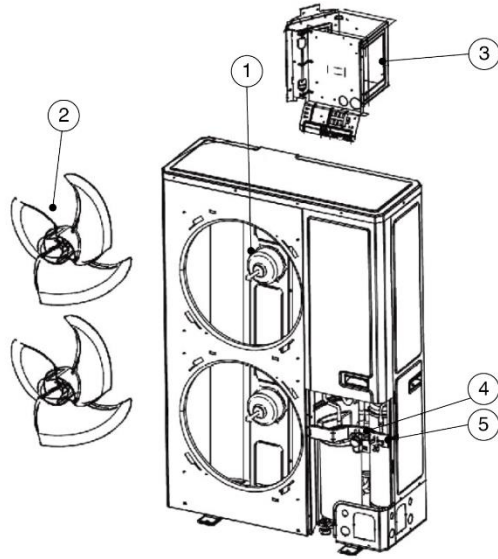

VRFO-36HP-V2B(55)5, VRFO-48HP-V2B(55)5

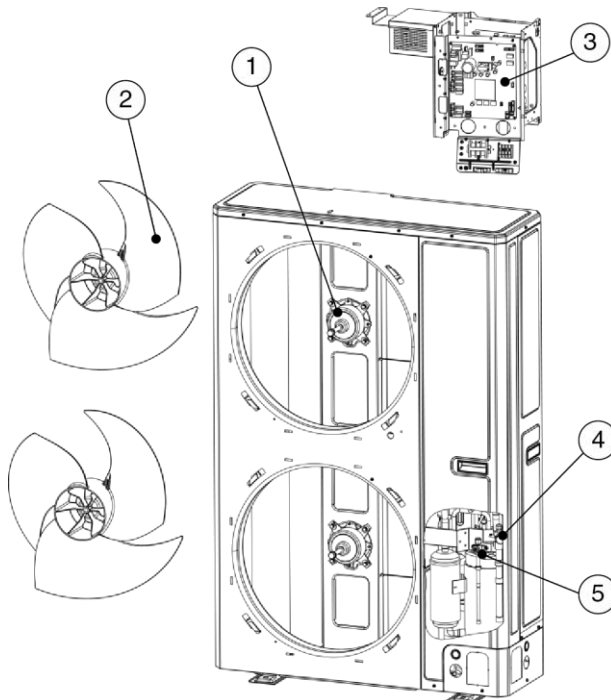

VRFO-60HP-V2B(55)5

No.	①	②	③	④	⑤
Name	Motor	Fan blade	Electric box assembly	Gas pipe valve	Liquid pipe valve

Combinations of Indoor and Outdoor Units

1. See table below for the number of indoor units that can be connected to the outdoor unit.
2. The total capacity of indoor units should be within 50%~135% of that rated for the outdoor unit.

Model	Min. Sets of Connectable IDUs	Max. Sets of Connectable IDUs
VRFO-36HP-V2B(55)	2	5
VRFO-48HP-V2B(55)	2	8
VRFO-60HP-V2B(55)	2	13

Outdoor units for DC Inverter Multi VRF System can be connected to various indoor units. When any one of the indoor units receives an operating command, the outdoor unit will start operation and supply per the required capacity for that unit. When all indoor units stop, the outdoor unit will turn off.

Operating Range

Cooling	Outdoor temperature: -5°C ~ 48°C (23°F~118°F)
Heating	Outdoor temperature: -20°C ~ 27°C (-4°F ~81°F)





Preparation Before Installation

NOTICE

Graphics here are only for reference. Please refer to actual products.

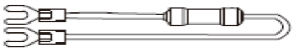
Standard Parts

Use only the supplied standard parts as required.

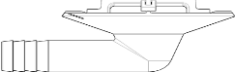
Parts for Outdoor Unit				
No.	Name	Appearance	Qty	Remark
1	User Manual		1	
2	Wiring (match with resistance)		1	Must be connected to the last IDU of communication connection
3	Corrugated pipe		1	VRFO-36HP-V2B(55)5 VRFO-48HP-V2B(55)5
4	Liquid side connection pipe		1	This part is included in the following models: VRFO-60HP-V2B(55)5
5	Gas side connection pipe		1	This part is included in the following models: VRFO-60HP-V2B(55)5
6	Drainage hole cap		3	
7	Drainage joint		1	

Installation Site

WARNING

- The unit must be secured/anchored in a manner where it will be strong enough to withstand the weight of the unit and prevent the unit from tipping or falling from its mounting even when exposed to strong winds.
- Do not install the unit in an area where it could be exposed to a combustible gas environment or gas leakage.
- Do not install the unit near a heat source, steam, or flammable gas.
- Children under 10 years of age must be supervised if they are operating the unit.
- Select an installation location where the unit will be out of a child's reach.
- Make sure the unit location has enough space to allow for adequate flow of air into inlet and allowing the outlet air to move freely which will allow for the heat exchange to work properly and allow space for easier maintenance. Good ventilation will help the unit to operate reliably.
- Install the unit where it will level. The unit must not be tilted by more than 5°.

NOTICE

- If possible, do not install the unit where it will be exposed to direct sunlight. (If necessary, install a blind that does not interfere with the air flow.)
- Install Outdoor Unit (ODU) in a place that will aid in keeping it clean, dust free and dry as possible.
- Install ODU where it is convenient to connect the Indoor Unit (IDU).
- The ODU and IDU should stay as close as possible to shorten the length of refrigerant pipe and reduce bend angles. There should be a minimum of 15 feet of refrigerant pipe between the ODU and the IDU.
- Install the ODU where the condensate water can be drained freely.
- Consider the weight of the air conditioner when selecting an installation location and secure in a manner keeping noise and vibration to a minimum.
- If the ODU is surrounded with walls, refer to the following figures for space requirement dimension:

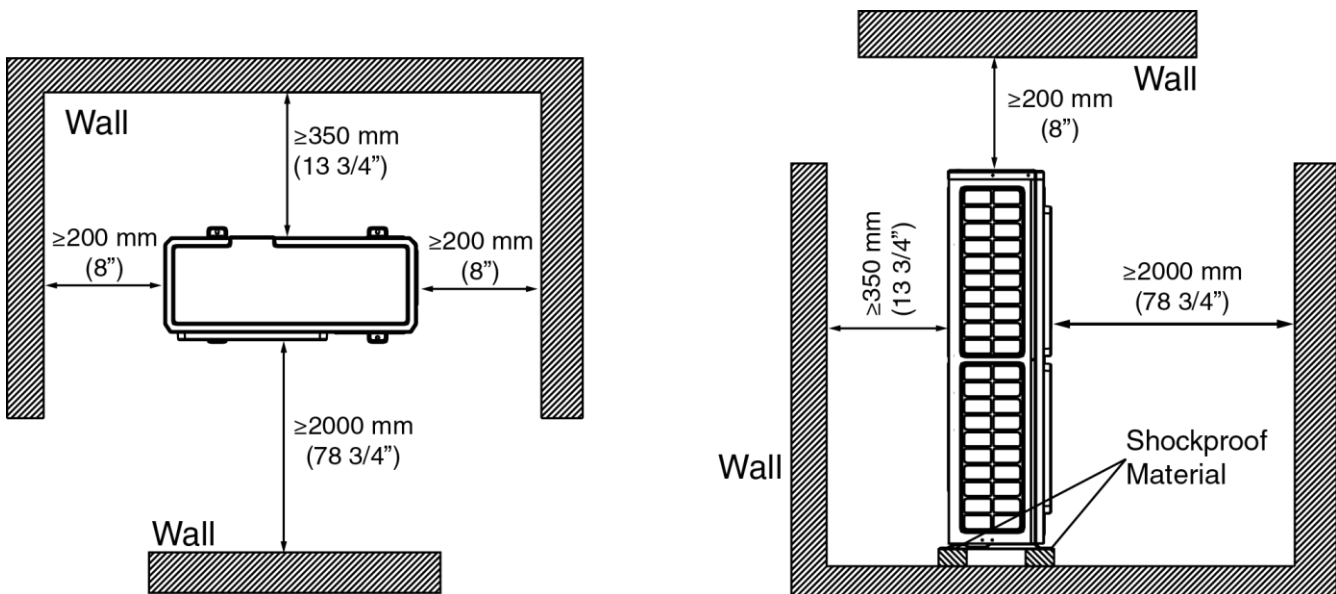

Piping Work Requirements

Refer to the table below for piping work requirements:

Outer Diameter (mm/inch)	Wall Thickness (mm/inch)
Ø6.35mm (Φ1/4")	≥0.8mm (1/32")
Ø9.52mm (Φ3/8")	≥0.8mm (1/32")
Ø12.7mm (Φ1/2")	≥0.8mm (1/32")
Ø15.9mm (Φ5/8")	≥1.0mm (1/25")
Ø19.05mm (Φ3/4")	≥1.0mm (1/25")

Installation Instructions

NOTICE

Graphics here are only for reference. Refer to actual products.

Dimension of Outdoor Unit and Mounting Holes

Unit Outline and Installation Dimensions:

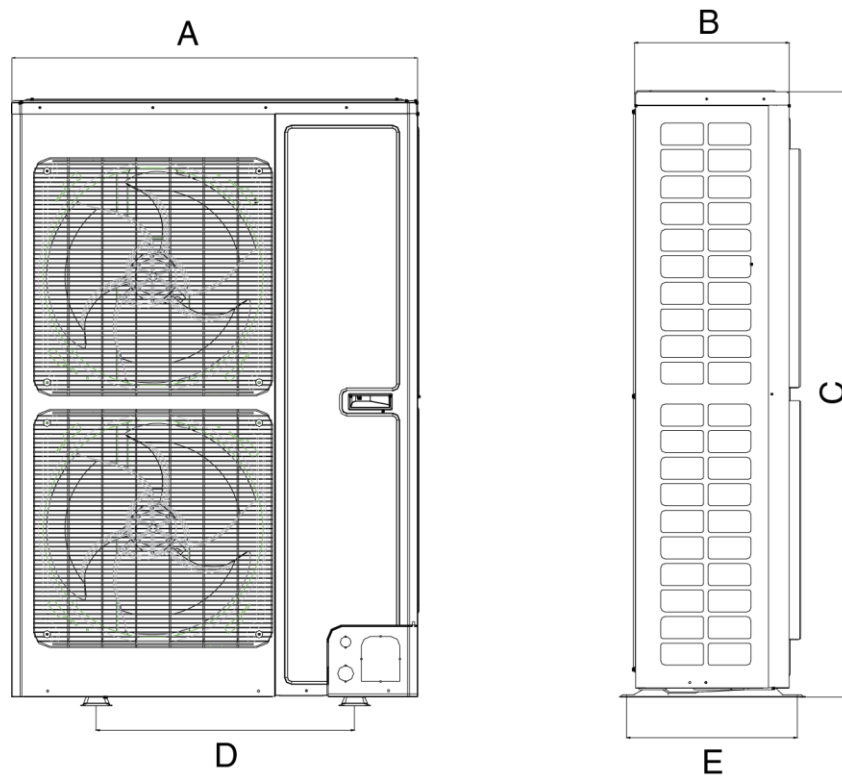

Model	A mm (inch)	B mm (inch)	C mm (inch)	D mm (inch)	E mm (inch)
VRFO-36HP-V2B(55)5	900mm (35-3/8")	340mm (13-3/8")	1345mm (53")	572mm (22-1/2")	378mm (15")
VRFO-48HP-V2B(55)5					
VRFO-60HP-V2B(55)5	940 (37)	320 (12 3/5)	1430 (56 9/32)	632 (24 7/8)	350 (14 7/8)

Connection Pipes Schematic Diagram of Piping Connection

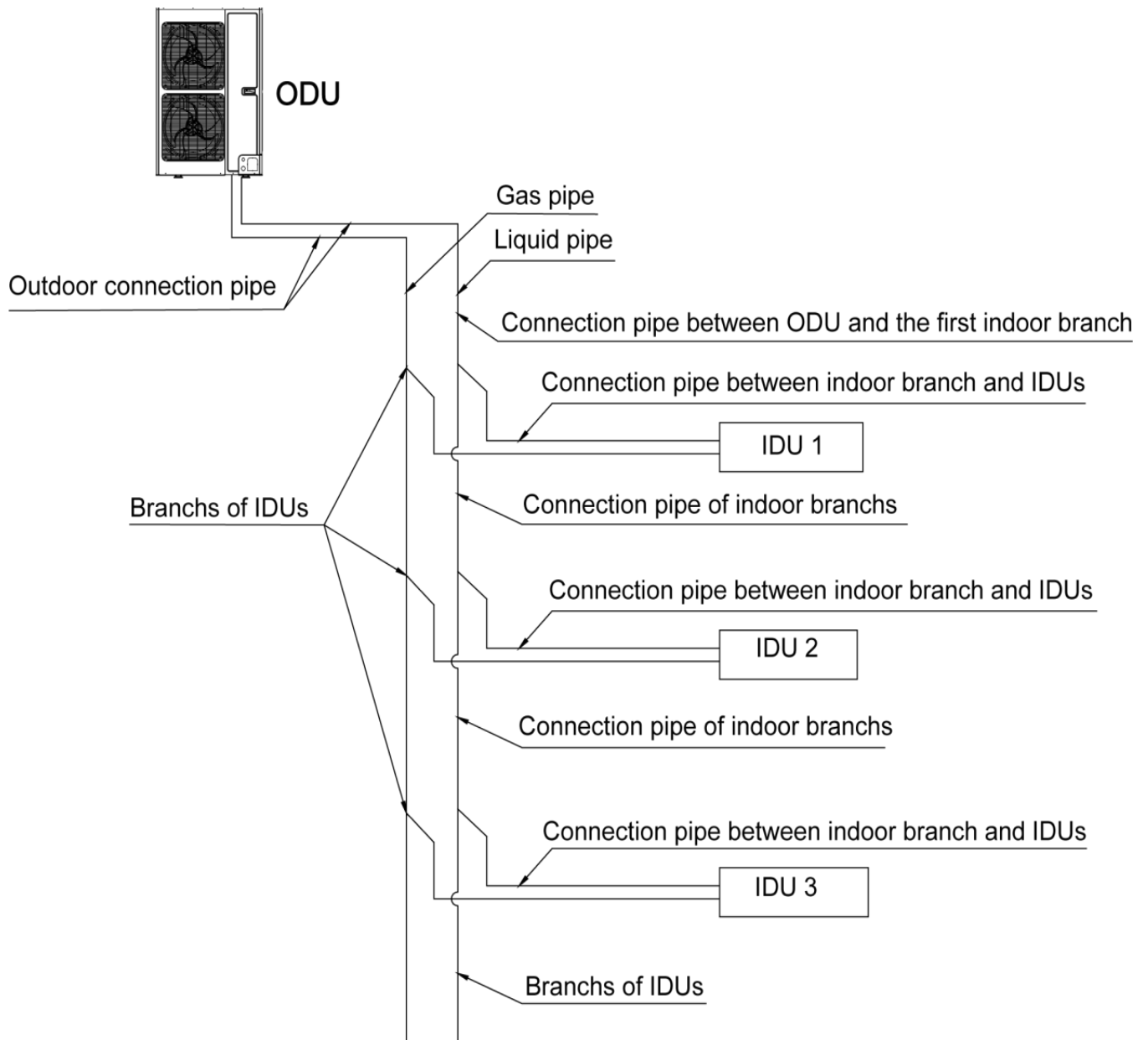

Allowable Length and Height Difference of Connection Pipe

“Y” type branch joint is used to connect the indoor and outdoor units. Connecting method is shown below:

NOTICE

Equivalent length of one “Y”-type branch is 0.5m (19.5 inches).

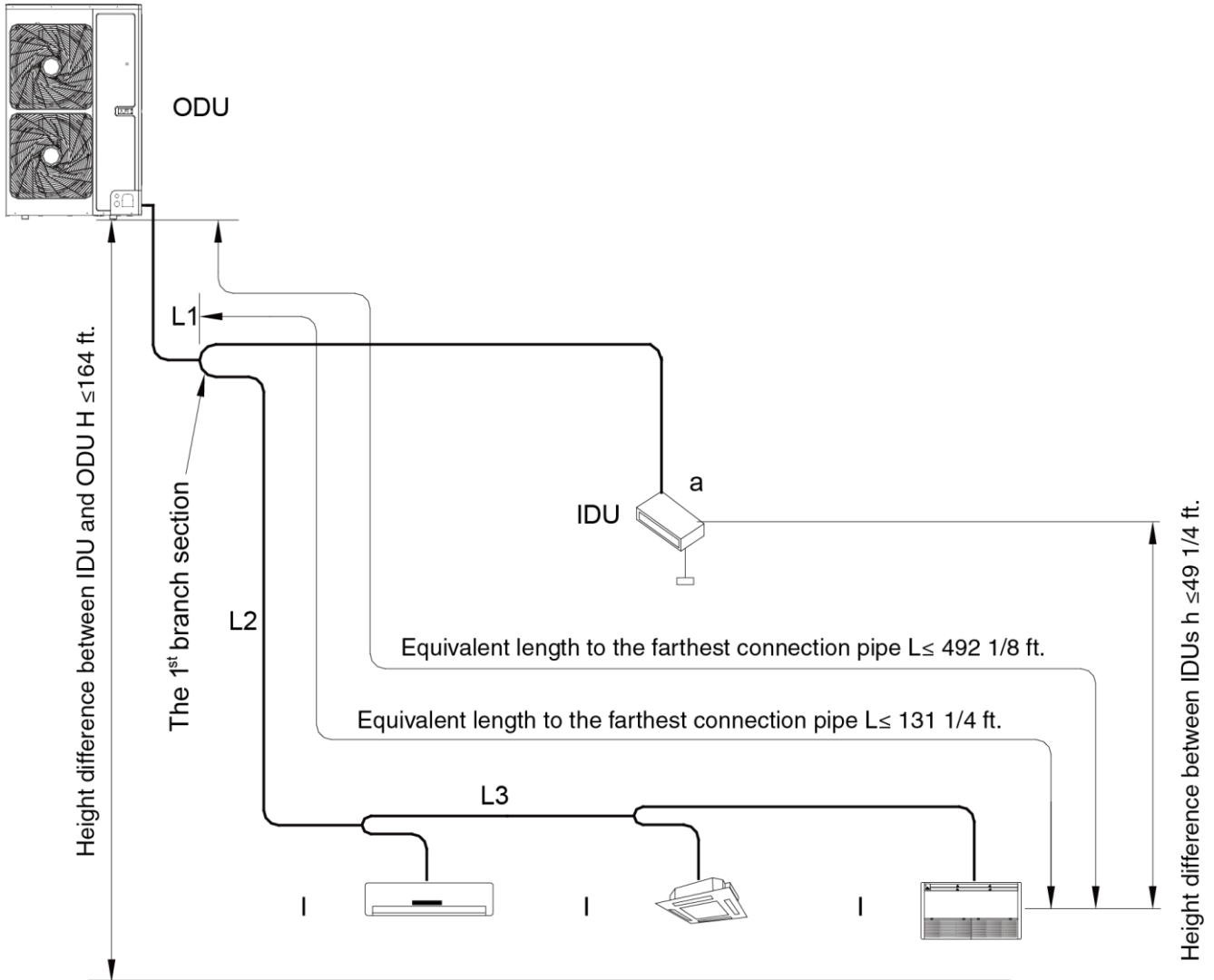

Each “Y” type branch equals to 0.5m (19.5 inches) and each branch header equals 1.0m (39 3/8 inches).

Allowable Length and Height Difference of Connection Pipe

Piping parameters of VRFO-36HP-V2B(55)5, VRFO-48HP-V2B(55)5, VRFO-60HP-V2B(55)5

Description	Allowable Value		Connection Pipe
	meters	feet	
Total length (actual length) of connection pipe	300	984	L1+L2+L3+a+b+c+d
Length of farthest connection pipe	Actual length	120	L1+L2+L3+d
	Equivalent length	150	
From the 1 st branch to the farthest indoor pipe	40	131	L2+L3+d
Height difference between ODU and IDU	ODU at upper side	50	—
	ODU at lower side	40	—
Height difference between IDUs	15	15	—

Dimension of Pipe (Main Pipe) from ODU to the 1st Indoor Branch

Dimension of pipe from ODU to the 1st indoor branch will be determined by the dimension of the outdoor connection pipe.

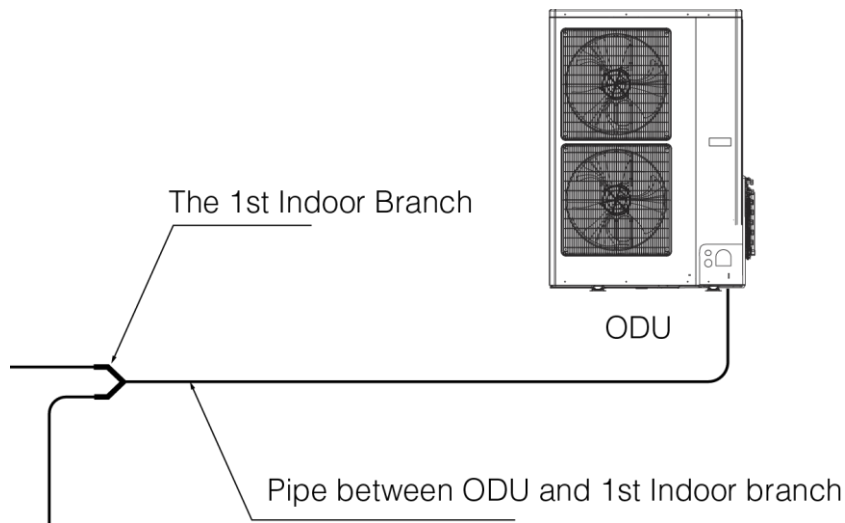

Dimension of Outdoor Connection Pipe:

Basic Module	Pipe dimension	
	Gas Pipe (mm/inch)	Liquid Pipe (mm/inch)
VRFO-36HP-V2B(55)5	Ø15.9 mm (Ø5/8")	Ø9.52 mm (Ø3/8")
VRFO-48HP-V2B(55)5	Ø15.9 mm (Ø5/8")	Ø9.52 mm (Ø3/8")
VRFO-60HP-V2B(55)5	Ø19.05 mm (Ø3/4")	Ø9.52 mm (Ø3/8")

Selection of Indoor Branches

Select indoor branches according to the total capacity of downstream indoor units.

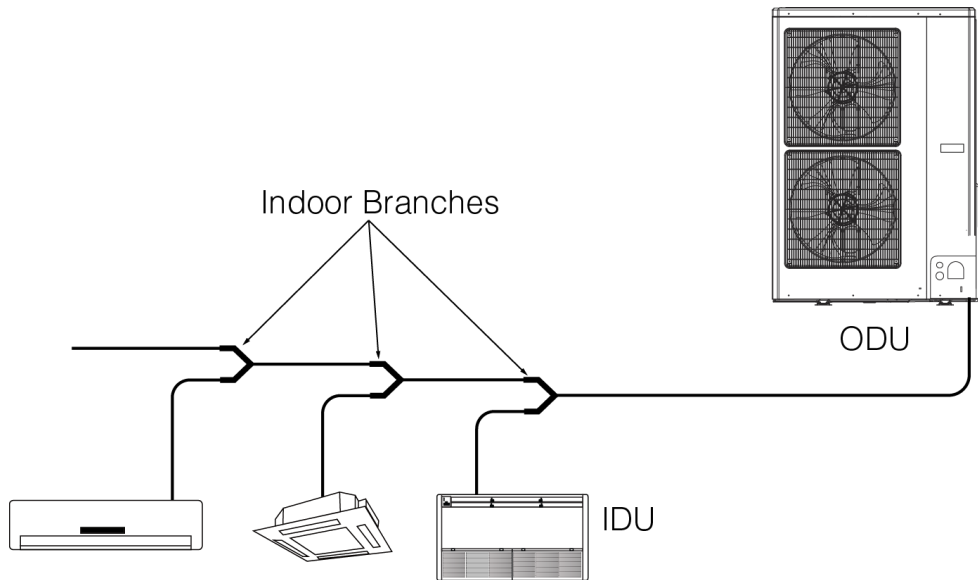

Refrigerant System	Total Capacity of Downstream Indoor Units C (Btu/h)	Model
"Y" Type Branch	$C < 68,8200$	VRFO-YtubeP-1AA
	$68,200 \leq C \leq 102,400$	VRFO-YtubeP-1BA
	$102,400 < C \leq 238,800$	VRFO-YtubeP-02A
	$238,800 < C \leq 460,600$	VRFO-YtubeP-03A
	$460,600 < C$	VRFO-YtubeP-04A

Dimension of Pipe between Indoor Branches

Select pipe between indoor branches according to the capacity of the downstream indoor units; if the capacity exceeds that of the outdoor unit, then the capacity of outdoor unit prevails.

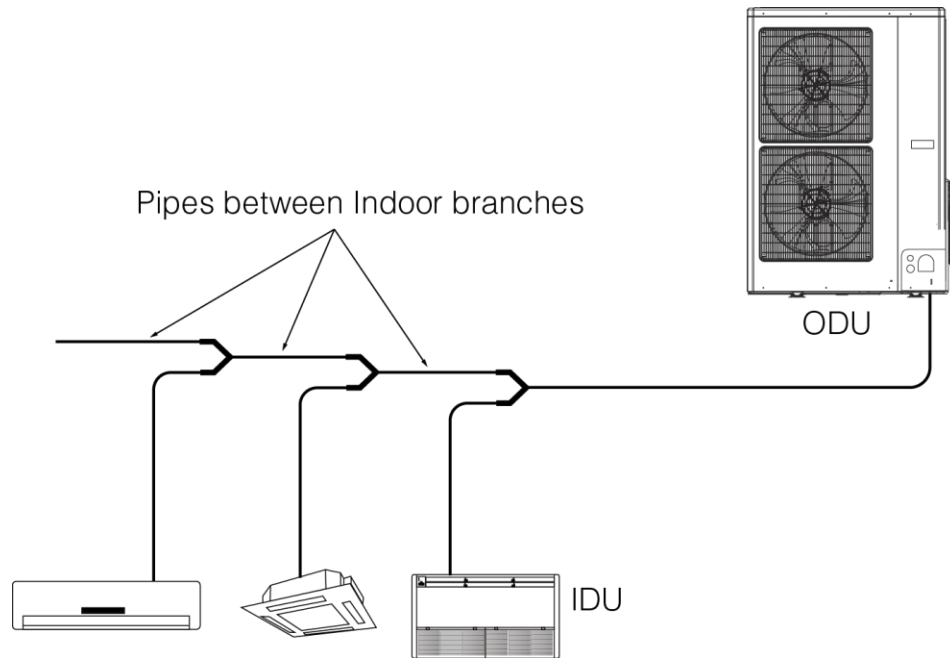

Total Capacity of Downstream Indoor Units C (Btu/h)	Pipe (mm/inch)	Liquid Pipe (mm/inch)
$C \leq 19000$	$\varnothing 12.7$ mm ($\varnothing 1/2$ ")	$\varnothing 6.35$ mm ($\varnothing 1/4$ ")
$19000 < C \leq 48500$	$\varnothing 15.9$ mm ($\varnothing 5/8$ ")	$\varnothing 9.52$ mm ($\varnothing 3/8$ ")
$48500 < C \leq 76400$	$\varnothing 19.05$ mm ($\varnothing 3/4$ ")	$\varnothing 9.52$ mm ($\varnothing 3/8$ ")

Dimension of Pipe Between Indoor Branch and IDU

Dimension of pipe between indoor branch and IDU should be consistent with the dimension of indoor pipe.

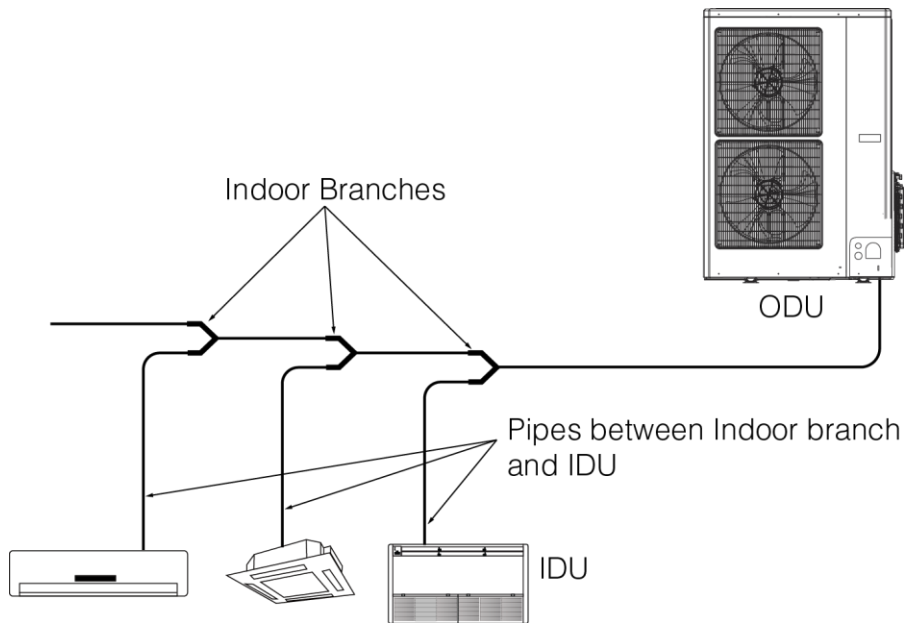

Rated capacity of IDU C(Btu/h)	Gas pipe (mm/inch)	Liquid pipe (mm/inch)
$C \leq 9600$	$\varnothing 9.52 \text{ mm}$ ($\varnothing 3/8''$)	$\varnothing 6.35 \text{ mm}$ ($\varnothing 1/4''$)
$9600 < C \leq 17000$	$\varnothing 12.7 \text{ mm}$ ($\varnothing 1/2''$)	$\varnothing 6.35 \text{ mm}$ ($\varnothing 1/4''$)
$17000 < C \leq 48000$	$\varnothing 15.9 \text{ mm}$ ($\varnothing 5/8''$)	$\varnothing 9.52 \text{ mm}$ ($\varnothing 3/8''$)
$48000 < C \leq 55000$	$\varnothing 19.05 \text{ mm}$ ($\varnothing 3/4''$)	$\varnothing 9.52 \text{ mm}$ ($\varnothing 3/8''$)
$55000 < C \leq 96000$	$\varnothing 22.2 \text{ mm}$ ($\varnothing 7/8''$)	$\varnothing 9.52 \text{ mm}$ ($\varnothing 3/8''$)

NOTICE

If the distance between the IDU and its nearest branch is over 10m (33 feet), then the liquid pipe of the IDU (rated capacity $\leq 17,000 \text{ Btu/h}$) shall be enlarged.

Installation of Connection Pipe

⚠ CAUTION

- Conform to the following principles during pipe connection: Connection pipe should be as short as possible, so is the height difference between indoor and outdoor units. Keep the number of bends as few as possible. Radius of pipe bends should be as large as possible.
- Weld the connection pipe between the indoor and outdoor units. Strictly follow the requirements for welding pipe progress. A rosin joint or pin hole is not allowed.
- When running pipe, be careful not to distort or damage it. The minimum radius for pipe bending should be 200mm (8inch). Note: Pipes cannot be repeatedly bent or stretched; this will make work harden the material. Do not bend or stretch the pipe more than 3 times at the same position.

Flaring Progress

1. Use a pipe cutter to cut the connection pipe, if it is bent or misshaped.
2. Keep the pipe pointed downward to keep the pipe clean and eliminate any debris from entering the pipe while cutting. Remove all burrs and sharp edges after cutting.
3. Remove the flared nut connecting indoor connection pipe and outdoor unit. Then use a flaring tool to fix the flared nut onto the pipe.
4. Check and ensure the flare on the part is flared evenly and there are no cracks.

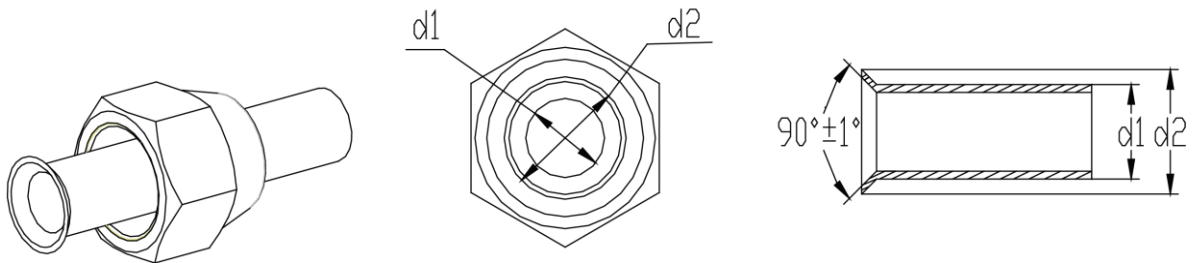

Pipe Bending

1. Reshape the pipe by hand. Be careful not to damage the pipe.
2. Do not bend the pipe more than 90°.
3. If the pipe is repeatedly bent or stretched, it will work harden and become difficult to bend and stretch again. Do not bend or stretch the bend more than 3 times.
4. If direct bending causes any cracks or damage to the pipe, repair the pipe. First use sharp cutter to cut the insulating layer, as shown below. Do not bend the pipe until it is exposed. When bending is complete, wrap the pipe with an insulating layer and then secure it with adhesive tape.

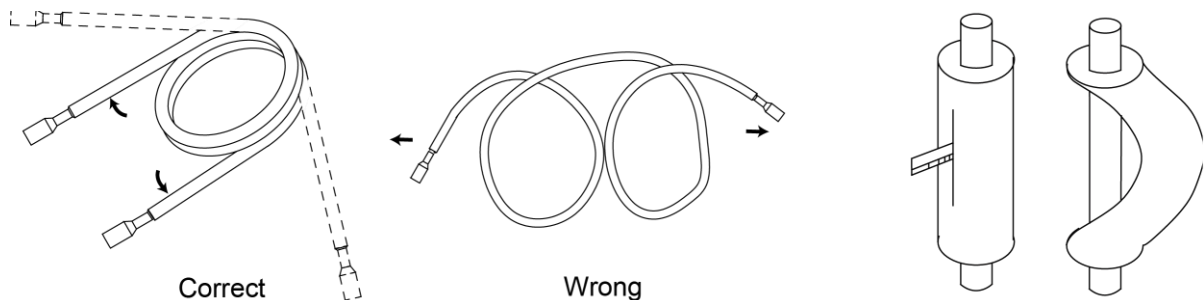

Indoor Pipe Connection

1. Remove the pipe cover and pipe plug.
2. Direct the flared part of copper pipe to the center of the fitting. By hand, twist on the flared nut securely, as shown below. (Make sure indoor pipe is correctly connected. Improper location of the center of the flare will prevent the flared nut from being sufficiently tightened. To avoid damage to the threads of the nut, do not force the nut, only use hand tightening.)
3. Use a torque wrench to secure the flared nut.

⚠ CAUTION

- Use an insulating material to wrap the un-insulated connection pipe and joint. Then secure the insulating material tightly with a strong, durable and waterproof tape that is also suited for the exposed temperatures.
- Connection pipes should be supported by a bracket or stand rather than by the unit.
- Avoid damaging the pipe by not making the bend angle too small. Always make the bends as large as possible, otherwise the piping might could have cracks. Always use a pipe bender to bend the pipe.
- When connecting IDU with connection pipe, do not apply too much force on either the big and small joints of IDU as this could result in cracks in the capillary tube or other tubes and cause leakage.

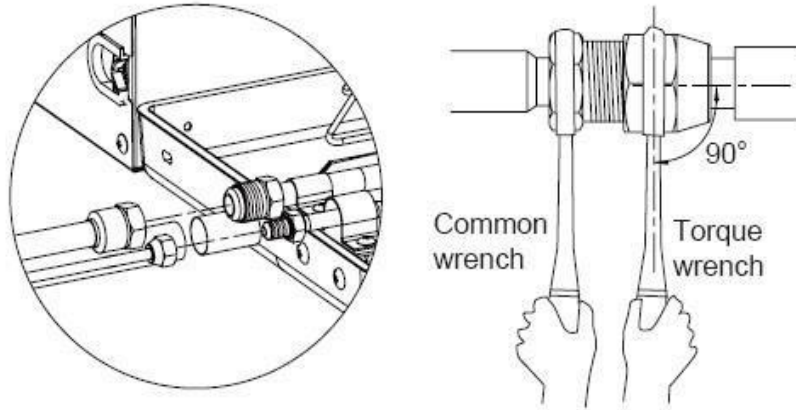

Pipe Diameter	Tightening Torque
6mm (1/4 inch)	15-30N·m (11-22ft.-lb.)
9.5mm (3/8 inch)	35-40N·m (26-29ft.-lb.)
12.7mm (1/2 inch)	45-50N·m (33-37ft.-lb.)
16mm (5/8 inch)	60-65N·m (44-48ft.-lb.)

Outdoor Pipe Connection

1. Pipe connection for VRFO-36HP-V2B(55)5, VRFO-48HP-V2B(55)5

Twist the flared nut onto the connection pipe of the outdoor valves. Twisting method is the same as for indoor pipe connection. According to customer requirement or space limit, outlet pipe can be installed from the front, right or rear side.

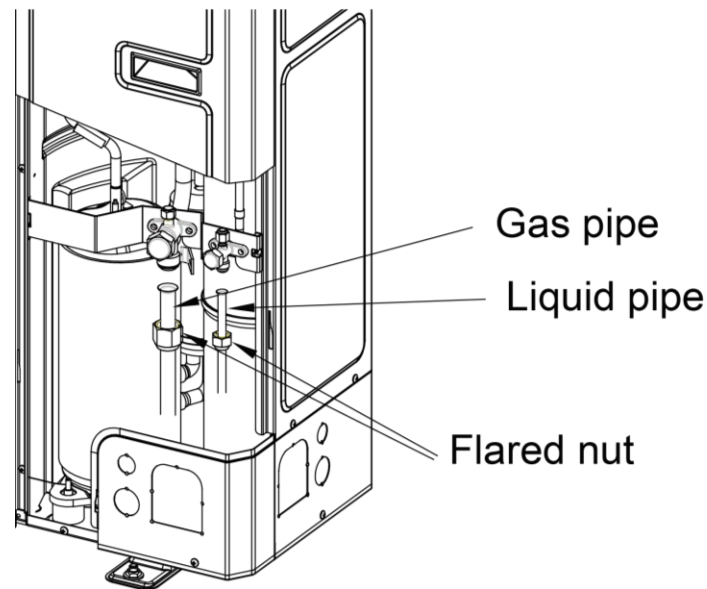

2. Pipe connection for VRFO-60HP-V2B(55)5

As shown in below, open the outermost soundproof cotton and place a fire barrier between compressor and straight pipe. Use a soldering gun to unsolder straight pipe 1 and straight pipe 2. Install connection pipe 1 and connection pipe 2 to their corresponding position and then seal the apertures with welding rod. First weld the liquid side connection pipe and then weld the gas side connection pipe. During welding, it's necessary to use wet gauze to wrap the two cut-off valves. Make sure the flame will not burn the soundproof cotton or other components.

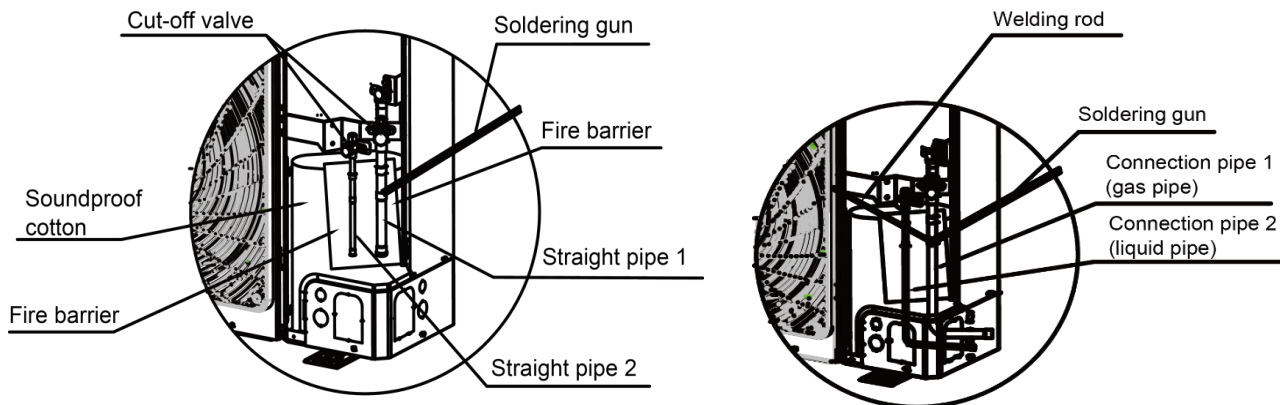

Installation of Y-type Branch

1. Y-Type Branch

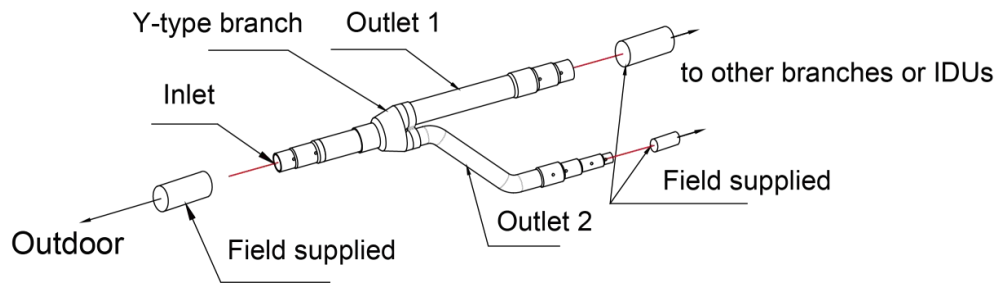

2. Y-type branch has several pipe sections with different dimension, which facilitates to match with various copper pipes. Use pipe cutter to cut in the middle of the pipe section that is of proper dimension and remove burrs as well.
3. Y-type branch must be installed vertically or horizontally.

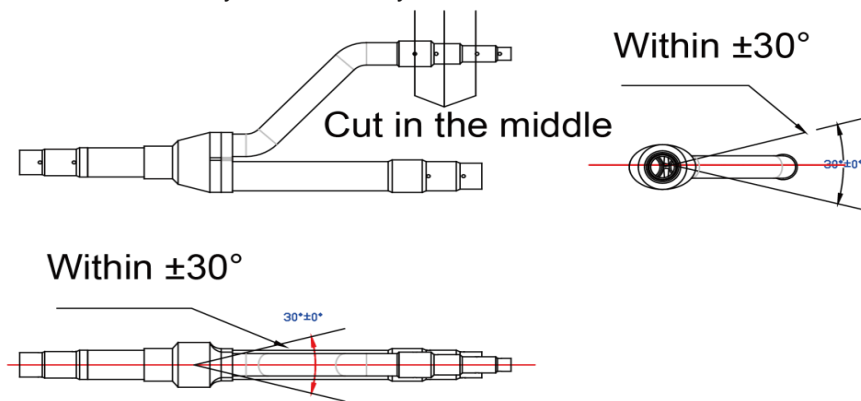

NOTICE

Branch shall be isolated with insulating material that can withstand temperatures of 120°C (248°F) or higher. The attached foam of branch is not considered insulating material.

Thermal Insulation for Pipeline

- For multi VRF systems, every copper pipe should be labeled to avoid misconnection of cross piping.
- At the branch inlet, leave at least 500mm (19-3/4inch) straight pipe section.
- Thermal insulation for pipeline: to avoid condensate or water leakage on the connection pipe, the gas pipe and liquid pipe, they must be wrapped with thermal insulating material and adhesive tape to insulate from the air.
- Joints of indoor and outdoor unit should be wrapped with insulating material and must have no gaps between pipe and wall.

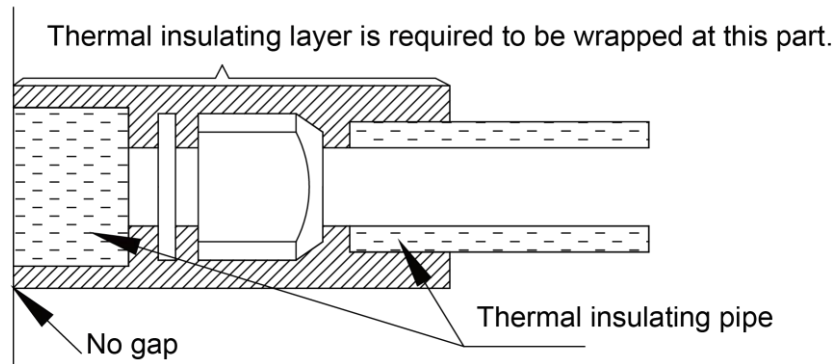

- When wrapping tape around the joint, the last circle should cover half of the previous circle. Avoid wrapping the tape too tight, otherwise the insulating effect will be weakened.
- After wrapping the pipe, apply a sealing material to completely seal the hole on the wall.

NOTICE

- Thermal insulating material shall be able to withstand the pipe temperature. For heat pump unit, liquid pipe should withstand 70°C (158°F) or above and gas pipe should withstand 120°C (248°F) or above. For cooling only unit, both liquid pipe and gas pipe should withstand 70°C (158°F) or above.
- Thermal insulating material of branches should be the same as that of the pipeline. The attached foam of the branches cannot be considered as an insulating material.

Support and Protection of Pipeline

CAUTION

- Supports should be made for hanging the connection pipe. Distance between each support cannot be over 1m (39-3/8 inches).
- Protection should be made for the outdoor pipeline to prevent accidents. When pipeline exceeds 1m (39-3/8 inches), a pinch board should be added for protection.

Disassembly of Compressor Feet

To prevent unit from being damaged during transportation, two metal pieces are fitted to the outdoor unit's compressor feet before unit leaves the factory.

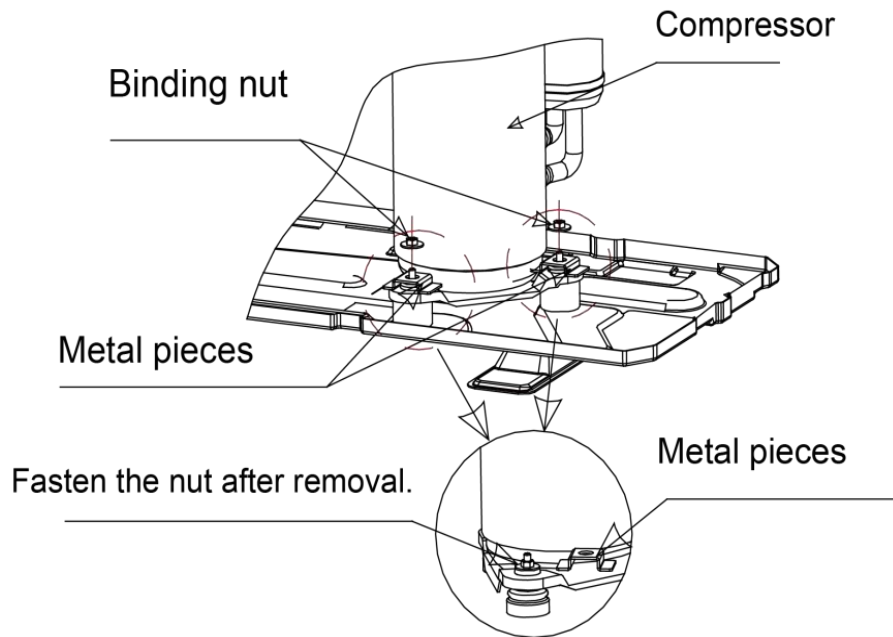

When installing the unit, the metal pieces for transportation must be removed, except for VRFO-60HP-V2B(55)5. Then fasten the binding nuts again and rewrap soundproofing cotton. If the unit runs with the metal pieces attached to the compressor, the compressor will shake abnormally, and the unit's operating life will be diminished.

Vacuum System, Adding Refrigerant

⚠ CAUTION

Do not purge to the system refrigerants to atmosphere but use a vacuum pump to vacuum the installation! There is no extra refrigerant in the outdoor unit to allow for air purging!

Vacuum System

1. Outdoor unit has been charged with refrigerant before delivery. Field-installed connection pipes need to be charged with additional refrigerant.
2. Confirm outdoor liquid and gas valves are closed.
3. Use a vacuum pump to remove the air inside the indoor unit and connection pipe from the outdoor valve, as shown below.

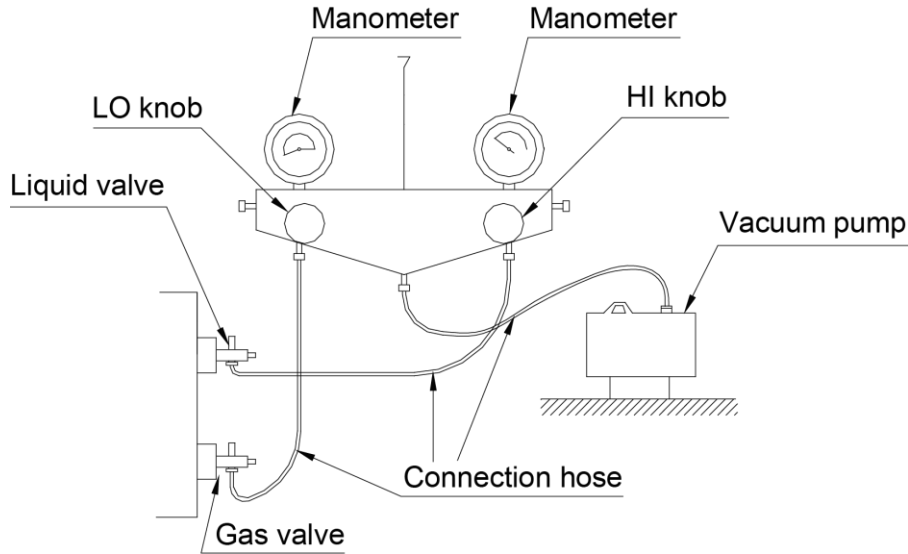

Adding Refrigerant

1. Refrigerant quantity of outdoor unit before delivery:

Model	VRFO-36HP-V2B(55)5	VRFO-48HP-V2B(55)5	VRFO-60HP-V2B(55)5
Refrigerant Qty (kg/oz)	5.0 (176)	5.0 (176)	6.5 (229)

NOTICE

- The refrigerant amount charged before delivery does not include the amount that needs to be added to the indoor units and the connection pipeline.
 - Length of connection pipe is determined on site. Therefore, the amount of additional refrigerant shall be decided on site according to the dimension and length of the field-installed liquid pipe.
 - Record the amount of additional refrigerant added. This record will a good reference for after-sales service.
2. Calculation of the amount of additional refrigerant; calculation method of the quantity of additional refrigerant (based on liquid pipe).
 3. Quantity of additional refrigerant = \sum length of liquid pipe X quantity of additional refrigerant per meter(393/8inch)

Diameter of Liquid Pipe (mm/inch)	Ø22.2 (Ø7/8)	Ø19.05 (Ø3/4)	Ø15.9 (Ø5/8)	Ø12.7 (Ø1/2)	Ø9.52 (Ø3/8)	Ø6.35 (Ø1/4)
kg/m	0.35	0.25	0.17	0.11	0.054	0.022
oz/inch	0.314	0.224	0.152	0.099	0.048	0.020

NOTICE

Liquid pipe that is within 20m (65' 7-1/2") does not need additional refrigerant.

First confirm that there is no leakage from the system. With the compressor off, charge system with a specific amount of additional R410a through the opened liquid pipe valve of the outdoor unit. If required amount cannot be quickly filled due to pressure increase of the pipe, then set the unit in cooling startup and fill refrigerant from the low-pressure check valve of the outdoor unit.

4. Calculation example

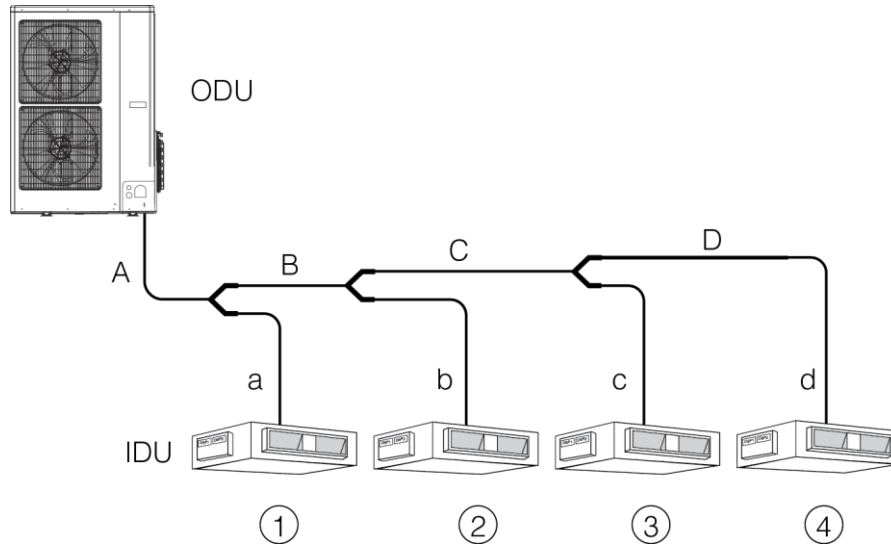

Fig. 23 IDU

No.	IDU ①	IDU ②	IDU ③	IDU ④
Model	Duct type VRFI-18EF-L2B(55)	Duct type VRFI-12EF-L2B(55)	Duct type VRFI-09EF-L2B(55)	Duct type VRFI-09EF-L2B(55)

Liquid pipe:

No.	A	B	C	D
Pipe size	Ø9.52mm (Ø3/8inch)	Ø9.52mm (Ø3/8inch)	Ø9.52mm (Ø3/8inch)	Ø6.35mm (Ø1/4inch)
Length	10m (32ft. 9in.)	5m (16ft. 4-1/2in.)	5m (16ft. 4-1/2in.)	5m (16ft. 4-1/2in.)
No.	a	b	c	d
Pipe size	Ø9.52mm (Ø3/8inch)	Ø6.35mm (Ø1/4inch)	Ø6.35mm (Ø1/4inch)	Ø6.35mm (Ø1/4inch)
Length	3m (9ft. 9in.)	3m (9ft. 9in.)	2m (6ft. 7-1/2in.)	1m (3ft 4in.)

Total length of each liquid pipe

Ø9.52 : A+B+C+a=10+5+5+3=23m (75ft. 6in.)

Ø6.35: D+b+c+d=5+3+2+1=11m (36ft.)

NOTICE

Liquid pipe that is within 20m (65ft. 7-1/2in.) does not need additional refrigerant.

Therefore, the minimum quantity of additional refrigerant = (23-20) × 0.054+11×0.022= 0.404kg(14oz)

System Wiring

⚠WARNING

- All of the electrical installation must be performed by qualified technicians in accordance with all national, state and local codes, regulations and this user manual.
- Use dedicated circuit for the air conditioner power supply and make sure that it is consistent with system's rated voltage and current ratings.
- Do not pull the power cord with excessive force.
- The power cord must be correctly sized for the unit (voltage, current and length). A damaged power cord or connection wire must be replaced with a new electrical cord.
- Connect the unit to the specialized grounding device and make sure it is securely grounded. It's required to install a correctly sized circuit breaker that can switch off the power to the entire system. The circuit breaker should include magnetic trip function and thermal trip function, so the system is protected from short circuit and overload.
- Air conditioner is a Class 1 electrical appliance, so it must be securely grounded.
- The yellow-green wire inside the unit is a ground wire. Do not cut it off or secure it with a self-tapping screw, as this will lead to an electric shock.
- Power supply must include a secure grounding terminal. Do not connect the ground wire to the following: ① Water pipe, ② Gas pipe, ③ Drain pipe, ④ Other places that are deemed as non-secure by professional technicians.

Electrical Wiring

1. For solid core wiring.
 - a) Cut the wire end with a wire cutter or wire-cutting pliers, then strip the insulation about 25mm (1 inch).
 - b) Using a screwdriver, remove the terminal screw(s) on the terminal board.
 - c) Using pliers, bend the solid wire to form a loop suitable for the size of the terminal screw.
 - d) Properly shape the loop on the end of the wire, place the loop around the terminal screw and on the terminal board and securely tighten the terminal screw using a screwdriver.
2. For strand wiring.
 - a) Cut the wire end with a wire cutter or wire-cutting pliers, then strip the insulation about 10mm (3/8inch).
 - b) Using a screwdriver, remove the terminal screw(s) on the terminal board.
 - c) Using a round terminal fastener or pliers, securely clamp a round terminal to each stripped wire end.
 - d) Place the terminal screw through the round terminal, and securely tighten the terminal screw using a screwdriver.

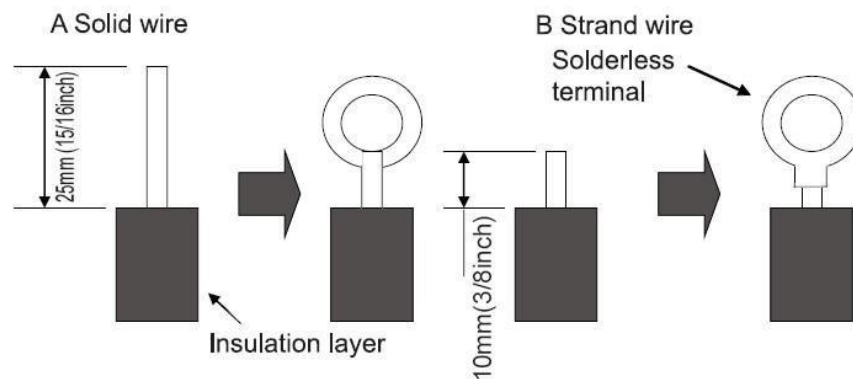

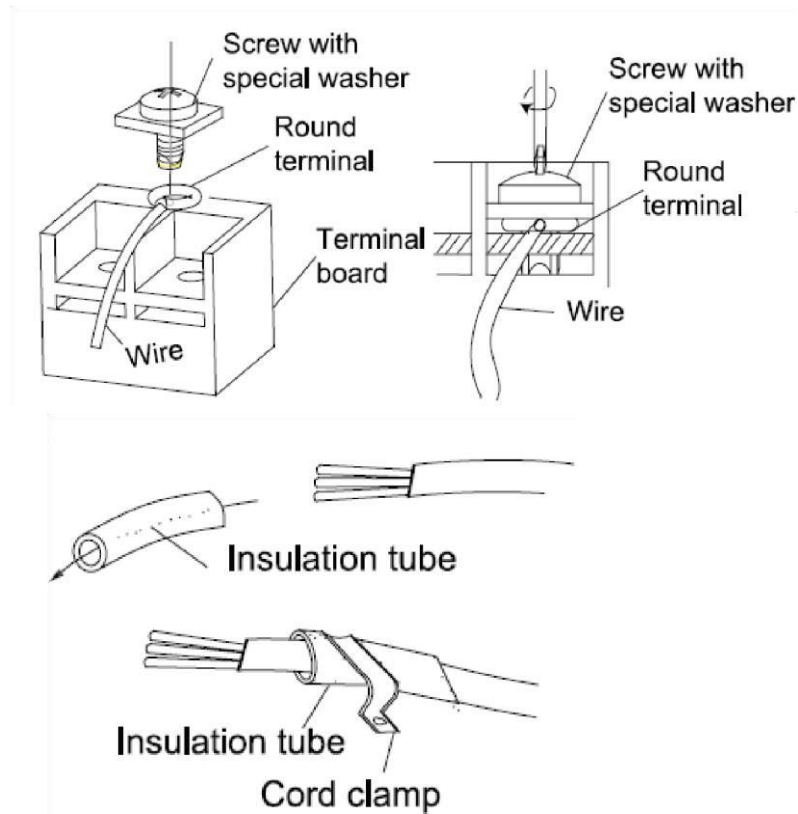

3. How to secure the connection cord and power cord using a cord clamp.
 - a) Pass the connection cord and power cord through the insulation tube, then secure it with the cord clamp.

⚠ WARNING

1. Before beginning any type of electrical work on the units, ensure the circuit breaker supplying power to the indoor unit and outdoor unit is switched off.
2. Match the terminal block numbers and connection cord colors with those of the indoor unit side. Erroneous wiring may cause burning of the electric parts.
3. Connect the connection wires securely to the terminal block. Loose terminal block connections can cause a fire.
4. Always fasten the outside covering of the connection cord with cord clamps. (If the insulator is not correctly clamped, electric leakage can occur.)
5. Always securely connect the ground wire.

Wiring Diagram

1. Connection of the power cord and communication wire. Separate power supply for the IDU and ODU.

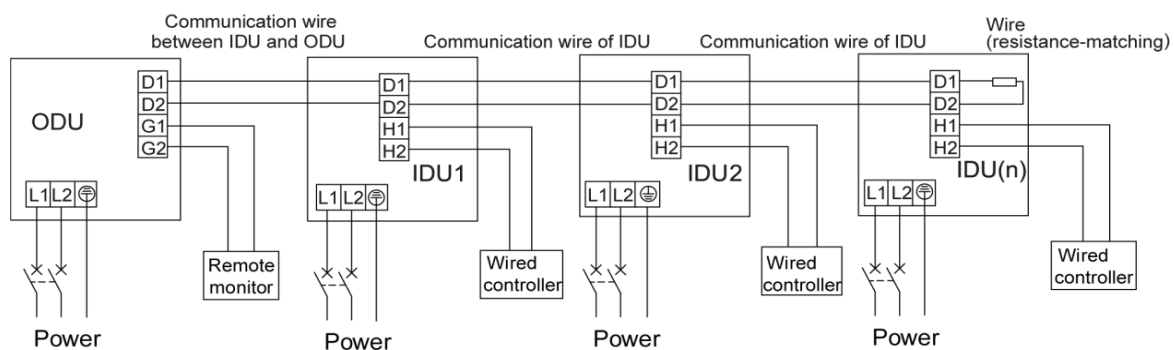

Connection of power cord and communication wire for IDU and ODU

2. The wiring diagram for the power cord of the outdoor unit and communication wire.

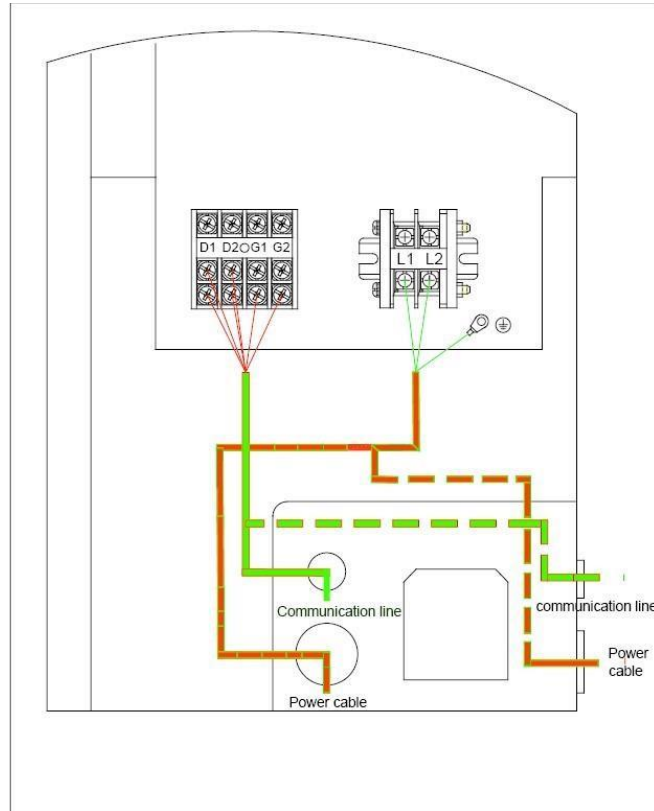

There are two wiring diagrams for communication wires of indoor/outdoor units and remote monitor:

- Real line method;
- Broken line method. Select it based on the actual installation situation.

There are two wiring diagrams for power cord:

- Real line method;
- Broken line method. Please select it based on the actual installation situation.

3. Selection of the circuit breaker and power cord:

Model	Power Supply	Maximum Fuse Size (A)	Maximum Circuit Breaker Size (A)	Minimum Circuit Amps (A)
VRFO-36HP-V2B(55)5	208/230V~ 60Hz	50	50	32
VRFO-48HP-V2B(55)5	208/230V~ 60Hz	60	60	37
VRFO-60HP-V2B(55)5	208/230V~ 60Hz	70	70	42

NOTICE

- Selection of the circuit breaker and power cord in the above table is based upon the unit's maximum power (maximum current).
- Specification of the power cord is based on the working condition where ambient temperature is 40°C (104°F) and multi-core copper cable (working temperature is 90°C (194°F), e.g. power cable with YJV cross-linked copper, insulated PE and PVC sheath) is lying on the surface of slot. If working condition changes, please adjust the specification according to national standard.
- Specification of the circuit breaker is based on the working condition where ambient temperature of the circuit breaker is 40°C (104°F). If working condition changes, please adjust the specification according to national standard.

Check Items after Installation and Test Operation

Check Items after Installation

Check Items	Possible Conditions Due to Improper Installation	Check
Each part of the unit is installed securely?	Unit may drop, shake or emit noise.	Yes / No
Gas leakage test was performed?	Insufficient cooling (heating) capacity.	Yes / No
Unit has proper thermal insulation?	There may be condensation and water dripping.	Yes / No
Drainage is smooth?	There may be condensation and water dripping.	Yes / No
Is the voltage in accordance with the rated voltage specified on the nameplate?	Unit may have a malfunction or components may get damaged.	Yes / No
Is the electric wiring and pipe connection installed correctly?	Unit may have malfunction or components may get damaged.	Yes / No
Unit is securely grounded?	Electrical leakage.	Yes / No
Power cord meets the required specification?	Unit may have malfunction or components may get damaged.	Yes / No
Is the air inlet/outlet blocked?	Insufficient cooling (heating) capacity.	Yes / No
Length of refrigerant pipe and the charging amount of refrigerant are recorded?	The refrigerant charging amount is not accurate.	Yes / No
Binding pieces on compressor feet are removed?	Compressor may get damaged.	Yes / No

Test operation and debugging

NOTICE

1. After finishing the first installation or replacing the main board of the outdoor unit, it is necessary to perform test operation and debugging. Otherwise, unit will not function.
2. Test operation and debugging must be performed by professional technicians or under the guidance of professional technicians.

Prepare the test operation and debugging

1. Do not connect power until all installation work is finished.
2. All control circuits and wires are correctly and securely connected.
3. Check whether the fixing loops for compressor feet are removed.
4. All small pieces, especially metal chips, thread ends and forceps holder, must be removed from the unit.
5. Check whether the unit's appearance and pipeline system has been damaged during transportation.
6. Calculate the quantity of refrigerant that needs to be added according to the pipe length. Pre-charge the refrigerant. In case that the required charging quantity is not reached while refrigerant is being added, record the quantity of refrigerant that still needs to be added and add the additional quantity during test operation. For details of adding refrigerant during test operation, see below.
7. After refrigerant is added, make sure the valves of the outdoor unit are completely open.
 - a) For the convenience of troubleshooting during debugging, unit shall be connected to a PC with applicable debugging software. Make sure unit's real-time data can be checked through this computer. The installation and connection of debugging software can be found in the *Service Manual*.
8. Before test operation, make sure unit power is on and compressor has been preheated for more than 8 hours. Touch the unit to check whether it's been preheated. If yes, start test operation. Otherwise, compressor might be damaged.

Test Operation and Debugging

Description of test operation procedures and main board display of ODU.

Description of Each Stage of Debugging Progress							
Progress	Debugging Code		Progress Code		Status Code		Code Meaning and Operation Method
	LED1		LED2		LED3		
	Code	Display Status	Code	Display Status	Code	Display Status	
01_ Set master unit	db	On	01	On	AO	On	System is not debugged.
	db	On	01	On	OC	On	Hold main board's SW7 button for 5 seconds to start debugging. Main board will display as said in the left. 2 seconds later, next step starts.
02_ Allocate addresses	db	On	02	On	Ad	Blink	System is allocating addresses. 10 seconds later, display as below:
	db	On	02	On	L7	Blink	No master indoor unit. Display will be on for 1 minute, during which master IDU can be set manually. If not, system will set the unit with minimum IP address as the master IDU.
	db	On	02	On	OC	On	Allocation is finished. 2 seconds later, next step starts.
03_ Confirm the quantity of ODU	db	On	03	On	01	Blink	System is confirming. 1 second later, next step starts.
	db	On	03	On	OC	On	System finishes confirmation. 2 seconds later, next step starts.
04_ Confirm the quantity of IDU	db	On	04	On	01~80	Blink	LED3 displays the quantity of indoor units. Confirm the number manually. If the number is not consistent the display one, turn off the power to the IDU and ODU and check whether communication wire of IDU is correctly connected. After the check, connect power and start debugging from progress 01. If the number is correct, press main board's SW7 button to confirm. Then the display is as below:
	db	On	04	On	OC	On	System has confirmed the quantity. 2 seconds later, next step starts.
05_ Detect ODU's internal communication and capacity ratio	db	On	05	On	C2	On	Communication between master ODU and driver has error. Check the communication connection of ODU's main board and drive board. When the error is eliminated, start next step. If power is off during troubleshooting, then restart debugging from progress 01 after power is turned on.
	db	On	05	On	OC	On	Communication of master ODU and driver is normal. Unit will display as in the left for 2 seconds and detect the capacity ratio of IDU and ODU. If the ratio is within range, then the next step will start 2 seconds later. If the ratio is out of range, unit will display as below:
	db	On	05	On	CH	On	Rated capacity ratio of IDU is too high. Change the combination way of IDU and ODU to make the ratio within range. And restart debugging from progress 01.
	db	On	05	On	CL	On	Rated capacity ratio of IDU is too low. Change the combination way of IDU and ODU to make the ratio within range. And restart debugging from progress 01.

06_ outdoor components	db	On	06	On	Error code	On	Outdoor component's error. LED3 will display the related error code. After errors are eliminated , system will start next step automatically. If power is off during troubleshooting, restart debugging from progress 01 after power is turned on.
	db	On	06	On	OC	On	System detects no error on outdoor component. 10 seconds later, next step starts.
07_ Detect indoor components	db	On	07	On	Error code	On	System detects error on indoor components. XXXX means the project code of IDU with error. After 3 seconds, related error code will be displayed. For instance, if no.1 IDU has d6 and d7 errors, then LED3 digital tube will display sequentially 00,01, d5, d6, 07, 92, d6, d7 every 2 seconds. After errors have been eliminated , system will start next step automatically. If power is off during troubleshooting, then restart debugging from progress 01 after power is turned on.
	db	On	07	On	OC	On	No error on components of IDU. 2 seconds later, next step starts.
08_ Confirm preheated compressor	db	On	08	On	UO	On	Preheat time for compressor is less than 8 hours. Display will be as in the left until the preheat time reaches 8 hours. Press main board's SW7 button to confirm manually that the preheat time has reached 8 hours. Then start next step. (Note: Compressor may be damaged if started without 8 hours of preheat time).
			08	On	OC	On	Compressor has been preheated for 8 hours. 2 seconds later, next step starts.
09_ Refrigerant judgments before startup	db	On	09	On	U4	On	System is low on refrigerant and display will be as in the left. Turn off power to IDU and ODU and check if there is leakage in pipeline. Solve the leakage problem and add refrigerant into the unit. Then connect power and restart debugging from progress 01. (Note: Before recharging refrigerant, unit must be powered off in case system starts progress 10 automatically.)
	db	On	09	On	OC	On	Refrigerant is normal, and unit will display as in the left for 2 seconds. Then next step starts
10_ Status judgments of outdoor valves before startup	db	On	10	On	ON	On	Valves of ODU are being inspected. Compressor will start operation for 2 minutes or so and then stop. The opening and closing status of outdoor valves are as below:
	db	On	10	On	U6	On	Outdoor valves are not fully turned on. Press main board's SW6 button and display shows "db 09 OC". Then check if the gas and liquid valves of ODU are completely open. After confirmation, press the SW6 button again . Then the compressor will start running for about 2 minutes to inspect the status of the valves.
	db	On	10	On	OC	On	Valves status is normal. Unit will display as in the left for 2 seconds and then start next step.
12_ Confirm debugging startup	db	db	12	On	AP	Blink	Ready for units to start debugging. Press main board's SW7 button to confirm startup of debugging. 2 seconds later, main board will display as below:
	db	On	12	On	AE	On	Startup is confirmed. After displaying for 2 seconds, system will choose "15_Cooling debugging" or "16_Heating debugging" according to ambient temperature. If the project requests to add refrigerant but it is not complemented before debugging, then refrigerant can be added in this progress through the L-VALVE.

15_ Cooling debugging	db	On	15	On	AC	On	Debugging for cooling mode. If no malfunction occurs for 20 minutes when the compressor is running, then system will start progress 17; If malfunction occurs, unit will display as below:
	db	On	15	On	Error code	On	Malfunction occurs when debugging for cooling mode. After all malfunctions are eliminated , system will start next step.
16_ Heating debugging	db	On	16	On	AH	On	Debugging for heating mode. If no malfunction occurs for 20 minutes when compressor is running, then system will start progress 17; If malfunction occurs, unit will display as below:
	db	On	16	On	Error code	On	Malfunction occurs when debugging for heating mode. After all malfunctions are eliminated , system will start next step.
17_ Debugging finished	00	On	AC/AH	On	OFF	On	The entire unit has finished debugging and under standby-by condition.

Appendix: Reference of normal operation parameters

No.	Debug Item		Parameter Name	Unit	Reference
1	System parameters	ODU parameters	Outdoor temperature	°C(°F)	—
2			Compressor discharge temperature	°C(°F)	<ul style="list-style-type: none"> When compressor starts, discharge temp in cool mode is within 70~105°C (158~221°F) and at least 10°C (50°F) higher than the high pressure saturation temp; As for temp in heat mode, it is within 65~90°C (149~194°F) and at least 10°C (50°F) higher than the high pressure saturation temperature.
3			Defrosting temperature	°C(°F)	<ul style="list-style-type: none"> In cool mode, defrosting temp is 4~10°C (39~50°F) lower than system's high pressure value. In heat mode, defrosting temp is about 2°C (36°F) different from system's low pressure value.
4			System high pressure	°C(°F)	<ul style="list-style-type: none"> In cool mode, the normal high pressure value is within 20°C~55°C (68~131°F). According to the change in ambient temperature and system's operating capacity, the high pressure value will be 10°C ~30°C (50~86°F) higher than ambient temperature. The higher ambient temp is, the smaller temperature difference is. If ambient temperature is 25~35°C (77~95°F) in cool mode, system's high pressure value will be within 44~53°C (111~127°F). In heat mode, if ambient temp is above 5°C (23°F), system's high pressure value is within 40~52°C (104~126°F). If ambient temperature is low and many IDUs are turned on, the high pressure will be lower.
5			System low pressure	°C(°F)	<ul style="list-style-type: none"> When ambient temperature in cool mode is 25~35°C (77~95°F), the low pressure value is 0~8°C (32~46°F). When ambient temp in heat mode is above -5°C (23°F), the low pressure value is -15~8°C (5~46°F).
6			Opening angle of thermal EXV	PLS	<ul style="list-style-type: none"> In cool mode, the thermal electronic expansion valve remains 480PLS. In heat mode, the adjustable opening angle of EXV is 60~480PLS.

No.	Debug Item		Parameter Name	Unit	Reference	
7			Compressor's operating frequency	HZ	VRFO-36HP-V2B(55)5 VRFO-48HP-V2B(55)5	Changes in 10Hz~80Hz.
					VRFO-60HP-V2B(55)5	Changes in 16Hz~80Hz
8			Compressor's operating current	A	When compressor works normally, the current is no more than 22.6A.	
9			Compressor's IPM temperature	°C(°F)	When ambient temp is below 35°C (95°F), IPM temperature is lower than 80°C (176°F) and the highest temperature won't be above 95°C (203°F).	
10			Fan motor's operating frequency	HZ	VRFO-36HP-V2B(55)5 VRFO-48HP-V2B(55)5	Changes in 0~49Hz according to system's pressure.
					VRFO-60HPV2B(55)5	Changes in 0~40Hz according to system's pressure.
11			IDU ambient temp	°C(°F)	—	
12						
13		IDU parameters	Indoor heat exchanger's inlet temp	°C(°F)	<ul style="list-style-type: none"> According to ambient temperature, for a same IDU in cool mode, the inlet temperature will be 1°C ~7°C (34~45°F) lower than the outlet temperature, and 4~9°C (39~48°F) higher than the low pressure value. For a same IDU in heat mode, the inlet temperature will be 10°C ~20°C (50~68°F) lower than the outlet temperature. 	
14		Opening angle of indoor EXV		PLS	VRFO-36HPV2B(55)5 VRFO-48HPV2B(55)5	<ul style="list-style-type: none"> In cool mode, the opening angle of indoor EXV varies within 70~480PLS. In heat mode, the opening angle of indoor EXV varies within 70~480PLS.
					VRFO-60HPV2B(55)5	<ul style="list-style-type: none"> In cool mode, the opening angle of indoor EXV varies within 70~480PLS. In heat mode, the opening angle of indoor EXV varies within 40~480PLS.
15	Communication parameters		Communication data	—	Number of IDUs detected by software is the same with the actual number. No communication errors.	
16	Drainage system		—	—	Number of IDUs detected by software is the same with the actual number. No communication errors.	
17	Others		—	—	Compressor and indoor/outdoor fan motor do not have strange noise. Unit can operate normally.	

Common Malfunctions and Troubleshooting

⚠WARNING

- If there is an abnormal condition (e.g. unpleasant smell), turn the unit off and disconnect the power immediately. Then contact your YMGI authorized service center. If the unit continues operation despite the abnormal condition, it may result in damaged to the unit and lead to electric shock or fire.
- Do not repair the air conditioner yourself. Improper repair or maintenance may lead to electric shock or fire. Contact your YMGI authorized service center for maintenance and repair.

Please check the items below before calling for maintenance.

Problems	Causes	What to do
Unit does not work.	Fuse or circuit breaker is off.	Replace fuse or reset the circuit breaker.
	Power failure	Restart unit when power is restored.
	Power is not connected.	Connect the power.
	Remote controller's power is low.	Replace the battery.
	Remote controller is out of the control range.	Control range is within 8m (26feet).
Unit runs but stops immediately.	Air inlet or air outlet of indoor and outdoor units are blocked.	Clear obstructions.
Abnormal cooling or heating	Air inlet or air outlet of indoor and outdoor units are blocked.	Clear obstructions.
	Improper temperature setting	Adjust setting at remote controller or wired controller.
	Fan speed is set too low.	Adjust setting at remote controller or wired controller.
	Air flow direction is not correct.	Adjust setting at remote controller or wired controller.
	Door or window is open.	Close the door or window.
	Direct sunshine	Close the curtain or blinds.
	Too many people in the room.	Reduce the number of people.
	Too many heat sources in the room.	Reduce heat sources.
	Filter is blocked and dirty.	Clean the filter.

NOTICE

If problem cannot be solved after checking the above items, contact your YMGI service center and describe the issues and have the model numbers ready.

The Following circumstances are not malfunctions.

Malfunction		Reason
Unit does not run.	Unit starts up immediately after it is turned off.	Overload protection switch makes it run after a 3-minute delay.
	Power has just turned on.	Standby operation lasts for about 1 minute.
Mist comes from the unit.	Under cooling	Indoor air with high humidity is cooled rapidly sometimes resulting in a mist.
Noise is emitted.	Slight cracking sound is heard when unit is just turned on.	The noise occurs when the electronic expansion valve is initialized.
	There is consecutive sound when cooling.	The sound is caused by refrigerant gas flowing in the unit.
	There is sound when unit starts or stops.	The sound occurs when gas refrigerant stops flowing.
	There is slight and consecutive sound when unit is running or after running.	The sound during drainage operation.
	Cracking sound is heard when unit is running or after running.	This sound is caused by the expansion of panels and other parts of the unit due to temperature change.
Unit blows out dust.	Unit starts up after not operating for a long time.	Dust in the indoor unit is being blown out.
Unit emits odor.	Under operation	Unit absorbs the room odor and then blows it out.

Error Indication

Exception class	Error	Outdoor Display	Indoor Display
Indoor	Indoor fan protection	L1	L1
	Water overflow protection	L3	L3
	Anti-freeze protection	L5	L5
	Mode conflict	-	L6
	Indoor ambient temperature sensor error	d3	d3
	Indoor coil inlet temperature sensor error	d4	d4
	Indoor mid-coil temperature sensor error	d5	d5
	Indoor coil outlet temperature sensor error	d6	d6
	Indoor humidity sensor error	d7	d7
	Jumper error	d9	d9
	Malfunction of lack of IDU	C4	C4
Outdoor	Outdoor ambient temperature sensor error	b1	b1
	Outdoor heat-exchanger coil outlet temperature sensor error	b3	b3
	Vapor-liquid separator inlet temperature sensor error	b6	b6
	High pressure protection	E1	E1
	Low pressure protection	E3	E3
	Discharge protection	E4	E4
	Refrigerant low protection	Ed	E0
	Compressor power protection	EN	E0
	Intermediate vapor injection temperature sensor error	Fb	E0
	EEPROM read-write error	F0	F0
	High pressure sensor error	F1	F1
	Middle pressure sensor error	F2	E0
	Low pressure sensor error	F3	F3
	Discharge temperature sensor error	F6	F6
	High pressure switch	Fd	E0
	AC over current	P5	P0
	IPM over current protection	PL	P0
	IPM module overheat	P8	P0
	Desynchronizing protection	P9	P0
	Busbar over voltage protection	PH	P0
	Phase current detection fault	PC	P0
	Busbar under voltage protection	PL	P0
	Capacitor charge error	PF	P0
	Demagnetization protection	PU	P0
	Communication error between indoor and outdoor units, indoor units wired controller	C0	C0
	485 communication error between main controller and drive controller	C2	C2
	Fan motor error	H0	H0
	PFC over current protection	P4	E0
	PFC module overheat	Pn	P0
	Phase loss protection of compressor	PE	P0
485 communication error between main controller and debugging controller	C1	-	

Inquiry method of error indication: combine division symbol and content symbol to check the corresponding error.
 For example, division symbol L and content symbol 4 together means over-current protection.

Division Symbol		Content Symbol	0	1	2	3	4	5
Indoor	L	Malfunction of IDU (uniform)		Protection of indoor fan	Auxiliary heating protection	Water-full protection	Over-current protection	Freeze prevention protection
	d			Indoor PCB is poor		Malfunction of ambient temperature sensor	Malfunction of entry-tube temperature sensor	Malfunction of middle temperature sensor
Outdoor	E	Malfunction of ODU (uniform)		High-pressure protection	Discharge low-temperature protection	Low-pressure protection	High discharge temperature protection of compressor	
	F	Main board of ODU is poor		Malfunction of high-pressure sensor		Malfunction of low-pressure sensor		Malfunction of discharge temperature sensor of compressor 1
	J			Over-current protection of compressor 1				
	b			Malfunction of outdoor ambient temperature sensor	Malfunction of defrosting temperature sensor 1		Malfunction of liquid temperature sensor of sub-cooler	Malfunction of gas temperature sensor of sub-cooler
	P	Malfunction of driving board of compressor (uniform)		Driving board of compressor operates abnormally (uniform)	Voltage protection of driving board power of compressor (uniform)	Reset protection of driving module of compressor	Drive PFC protection of compressor	Over-current protection of inverter compressor
Debugging	U	Preheat time of compressor is insufficient			Wrong setting of ODU's capacity code/jumper cap			Wrong address for driving board of compressor
	C	Communication malfunction between IDU, ODU and IDU's wired controller			Communication malfunction between main control and inverter compressor driver		Malfunction of lack of IDU	Alarm because project code of IDU is inconsistent
Status	A	Unit waiting for debugging		Inquiry of compressor operation parameters		Defrosting	Oil-return	Online test
	n	SE operation setting of system		Setting of defrosting cycle K1	Setting of upper limit of IDU/ODU capacity distribution ratio			

Division Symbol		Content Symbol	6	7	8	9	A	H
Indoor	L	Mode Shock	No Main IDU	Power Supply insufficient	1-to-more: number of IDU's is inconsistent	1-to-more: number of IDU's is inconsistent	Alarm due to bad air quality (Fresh air unit)	
	d	Malfunction of exit-tube temperature sensor	Malfunction of humidity sensor		Malfunction of jumper cap	Web address of IDU is abnormal	PCB of wired controller is abnormal	
	J		Gas-mixing protection of 4-way valve	High pressure ratio protection of system		Protection due to abnormal pressure		
	b	Malfunction of inlet temperature sensor of gas-liquid separator	Malfunction of outlet temperature sensor of gas-liquid separator		Malfunction of heat exchanger temperature sensor		Clock of system is abnormal	
	P	Drive IPM module protection of compressor	Malfunction of drive temperature sensor compressor	Drive IPM high temperature protection of compressor	Desynchronizing protection of inverter compressor		High-voltage protect on compressor's drive DC bus bar	
Debugging	U	Alarm because valve is abnormal		Short-circuit malfunction of IDU	Malfunction of pipe-line for ODU			
	C						Rated capacity is too high	
Status	A	Heat pump function setting	Quiet mode setting	Vacuum pump mode	IPLV test	EU AA level EER test mode	Heating	
	n	Malfunction inquiry of unit	Parameter inquiry of unit	Engineering No. inquiry of indoor unit		Heat pump unit	Heating only unit	

Division Symbol \ Content Symbol		Content Symbol					
		C	L	E	F	J	P
Indoor	L	Models for IDU and ODU are not matched					
	d	Abnormal setting for capacity button	Malfunction of air-outlet temperature sensor (fresh air unit)	Malfunction of indoor CO ₂ sensor (fresh air unit)			
	E	Drop protection of discharge temperature sensor of compressor 1					
	F						Malfunction of DC motor
	J		High-pressure protection				
	P	Drive current detection circuit malfunction of compressor	Low-voltage protection of compressor's drive DC bus bar	Phase-lacking an inverter compressor	Drive charging circuit malfunction of compressor	Failure startup of inverter compressor	AC current protection of inverter compressor
	H	Drive current detection circuit malfunction of Fan	Low-voltage protection of fan's drive DC bus bar	Phase-lacking inverter Fan	Drive charging circuit malfunction of fan	Failure startup of inverter fan	AC current protection of inverter fan
Debugging	U	Setting of main IDU is successful	Wrong button-dial	Charging refrigerant is invalid			
	C	Malfunction of lack of main control unit	Rated capacity is too low		Malfunction of multiple main control units	Malfunction of multiple main wired controllers	Malfunction of multiple main wired controllers
Status	A	Cooling	Charging refrigerant automatically	Charging refrigerant manually	Fan	Alarm for cleaning filter	Debugging confirmation for startup of unit
	n	Cooling only unit		Negative sign code	Fan Model		

Division Symbol \ Content Symbol		Content Symbol				
		U	b	d	n	y
Debugging	C	Communication malfunction between IDU and the receiving lamp plate	Overflow distribution of IP address			
Status	A	Long-distance emergency stop	Emergency stop of operation	Limit operation		

Function Setting of Outdoor Unit

When debugging is finished, press SW3 on the master unit and unit will be ready for function setting. Default display of outdoor unit's main board is as below:

LED1		LED2		LED3	
Function Code	Display	Current Progress	Display	Current Status	Display
A7	Blink	00	Blink	00	Blink

Then press SW1 button (▲) and SW2 button (▼) on the master unit to switch function codes of LED1 to select relevant functions. Function setting includes: outdoor silent mode setting (A7), heating and cooling function setting (A6), compulsory defrosting (n3). After selecting relevant functions, press SW7 to confirm and start setting this function. Main board of outdoor unit will display as below:

LED1		LED2		LED3	
Function Code	Display	Current Progress	Display	Current Status	Display
A7	On	00	Blink	oC	Blink
A6	On	CH	Blink	CH	Blink
n3	On	35	Blink	oC	Blink

ODU Quiet Function

This function is suitable for projects that have strict requirements for noise. It includes two modes: smart night silent mode, compulsory silent mode.

When unit enters function setting, main board of outdoor unit will display as below:

LED1		LED2		LED3	
	Display	Current Progress	Display	Current Status	Display
A7	On	00	Blink	oC	Blink

Press SW1 button (▲) and SW2 button (▼) to select the following silent modes.

LED1	LED2		LED3	
Function Code	Silent Mode	Display	Current Status	Display
A7	00~12	Blink	oC	Blink

When applicable mode is selected, press SW7 to confirm. Main board of outdoor unit will display as below:

LED1	LED2		LED3	
Function Code	Silent Mode	Display	Current Status	Display
A7	00~12	On	oC	On

NOTICE

Code 00 of LED2 refers to normal mode. Codes 01~09 refer to smart night silent mode. Codes 10~12 refer to compulsory silent mode. When setting is finished, master unit will memorize it so that it can't be cancelled even when power is on or off.

Then press SW6 on the master unit to return to the previous step. (If this button is pressed when function is being set, system will return to the previous step. If SW6 is pressed when setting is finished, system will resume displaying the current operation status.)

If then no motion is taken to the master unit for 5min, unit will exit and resume displaying the current status.

Cool & Heat Function

This function can set operation modes and prevent mode collision that is caused by setting different modes for different indoor units. It is especially suitable for hotels and other small business areas. There are 3 levels for this setting:

Level A-Mode Lock Control

Upon entering this function setting, main board of outdoor unit will display as below:

LED1	LED2		LED3	
Function Code	Current Progress	Display	Current Status	Display
A6	nC	Blink	nC	Blink

Press SW1 button (▲) and SW2 button (▼) to select the following functions:

LED1		LED2		LED3	
Function Code	Display	Current Progress/Mode	Display	Current Status	Display
A6	On	nC	Blink	nC	Blink
A6	On	nH	Blink	nH	Blink
A6	On	nA	Blink	nA	Blink
A6	On	nF	Blink	nF	Blink

When applicable mode is selected, press SW7 to confirm. The related display is as below:

LED1		LED2		LED3	
Function Code	Display	Current Progress/mode	Display	Current Status	Display
A6	On	nC	On	nC	On
A6	On	nH	On	nH	On
A6	On	nA	On	nA	On
A6	On	nF	On	nF	On

1. This setting will be memorized by master unit and can't be cancelled even when power is on or off.
2. Then press SW6 on the master unit to return to the previous step.
3. If then no motion is taken to the master unit for 5 minutes, unit will exit and resume displaying the current status.
4. If this button is pressed when function is being set, system will return to the previous step.
5. If SW6 is pressed when setting is finished, system will resume displaying the current operation status.
6. Default setting is "nA" cooling and heating type.

Level B—IDU Mode Auto Control

When Level A is disabled, or outdoor unit is set to cooling and heating type, the operation mode within one system depends on the master-slave setting of indoor units.

Forced Defrosting

This function can only be set when outdoor compressor is running.

Upon entering this function, main board of outdoor unit will display as below:

LED1		LED2		LED3	
Function Code	Display	Current Progress/Mode	Display	Current Status	Display
n3	On	00	Blink	00	Blink

Press SW7 to confirm. When system enters this function, main board of outdoor unit will display as below:

LED1		LED2		LED3	
Function Code	Display	Current Progress/mode	Display	Current Status	Display
n3	On	00	On	00	On

Then unit will be in compulsory defrosting mode. Once unit is under compulsory defrosting, this mode can only be stopped when requirements for exit are met.

Restore Factory Defaults

1. If you want to restore factory defaults, hold SW8 button on the main board of ODU for more than 10s, then all LEDs will blink for 3s. Main board will cancel all setting, including the IP addresses and project codes of IDU and ODU. The mark for finished debugging is “0”.
2. If you want to restore factory defaults and don't need project debugging, then hold SW3 and SW8 on the main board of ODU for more than 10s, then all LEDs will blink for 5s. All settings are cleared out, including the IP addresses and project codes of IDU and ODU. The mark for finished debugging remains the same.
3. When you only want to restore the default functions, hold SW5 and SW8 button for more than 10s, then all LED will blink for 7s. All function settings are cleared out, but IDU and ODU's project codes and the mark for finished debugging remain the same.

Static Pressure Function

If ODU's installation area is not convenient for releasing air and users do not have strict requirements for ODU noise, this function can be set to satisfy the heat exchange of ODU. Before powering on, set codes of SA6 on main board.

The relevant static pressure is:

Code setting SA6		Static Pressure (Pa)
DIP1	DIP2	
0	0	0
1	0	20

Note: code of number side is “1”; default code of SA6 is “00”.

Maintenance and Care

Regular checks, maintenance and care can extend the unit's service life. Always have specially trained person in charge of the management of the air conditioners.

Outdoor Heat Exchanger

Outdoor heat exchanger must be cleaned regularly, which is at least once every two months. You can use a dust catcher with nylon brush to clean away the dust on the heat exchanger. If compressed air is available, it also can be used to clean the heat exchanger. Do not clean it with water.

Drain Pipe

Regularly check drain pipe and ensure it is not blocked. Make sure condensate can be drained smoothly.

Notice before Seasonal Use

1. Check air inlets and air outlets of indoor and outdoor units are not blocked;
2. Check ground connection and ensure it is reliable.
3. Check batteries in the remote controller and ensure they are good if not replace them.
4. Check air filter and ensure it is properly installed.
5. If unit starts up after not operating for a long time, it should be powered on for 8 hours before operation starts so as to preheat the outdoor compressor.
6. Check outdoor unit and ensure it has been and is securely installed. If there is any problem, Contact your YMGI authorized service center.

Maintenance after Seasonal Use

1. Disconnect power from the entire system.
2. Clean the air filter and outer case of indoor and outdoor units.
3. Clean away the dust and obstacles from indoor and outdoor units.
4. If outdoor unit has rust, apply some paint to it to prevent the rust from spreading.

Parts Replacement

Parts and components can be obtained from YMGI office or YMGI distributor.

⚠WARNING

When you are conducting air tightness test and leakage test, do not mix oxygen, C₂H₂ or other dangerous gas into the refrigerant circuit. Otherwise, it may lead to danger. Use nitrogen or refrigerant to conduct the tests.

After-sales Service

If there's a quality defect or other problems with the product, please contact YMGI for after-sales service department for help.

Warranty must be based on the following conditions:

- Product's initial startup must be performed by professional technicians from YMGI's service center or persons assigned by YMGI.
- Only YMGI spare parts are used.
- All instructions of unit operation and maintenance in this manual must be strictly followed according to set period and set frequency.
- Any breach of the above conditions will void the warranty.



YMG I is dedicated to designing, manufacturing and distributing the highest quality, energy saving and environmentally friendly air conditioner and heat pump products, while providing the best service and support to all of our customers. Our mission is to help build a sustainable, efficient and green world.

YMG I Symphony-Ductless & Ducted Heat Pump & Heat Recovery:

- **Symphony SOLAR DC Inverter**
 (56) Single PV, (79) Single PH 12-18K Btu/h
 (86) Single Zone All DC 09-24K Btu/h
 (55) Multi Zone Solar VRF 3, 4, 8, 16, and 24 Ton.
- **Symphony SOLO DC Inverter**
 (54) Series -22 °F Heat Pump and Universal Cabinet
 (57)2,3 Single Zone 16 SEER, 09-36K Btu/h
 (58)4, (78)1-Single Zone 18-23 SEER, 09-36K Btu/h
- **Symphony CHOIR DC Inverter**
 (46)2 DC Inverter Multiple Zone 15 SEER, 2x09K and 2x12K Btu/h
 (59)2S-DC Inverter Multiple Zone 16 SEER 6x09K to 9x09K Btu/h
 (59)4-DC Inverter Multiple Zone 21 SEER 2x09K to 5x12K Btu/h
- **Symphony VRF - DC Inverter HP, Heat Recovery, and Solar. Up to 64 zones.**
 (55)5 -4°F Heat Pump, Heat Recovery
 (55)5 -22°F Ultra Heating Heat Pump, Heat Recovery
Air Source and Water Source
- **Symphony HARMONY-Packaged Self-Contained**
 42"x16" PTAC/PTHP Electric Heater or Hot Water Coil
 26"x16" TTWA
 VPAK
- **Symphony CONDUCTOR-Split Type Condensing Units**
 Side Discharge VRUO, YTAC & SHCR

YMG I Group

601 Arrow Ln, O'Fallon, MO 63366

www.YmgiGroup.com

Tel: 866-833-3138 • Fax: 866-377-3355

Email: info@YmgiGroup.com

Unit appearance and specifications are subject to change without notice.

Copyright ©2021 YMG I Group

