



(86) All DC Mini Split Single Zone Solar PV with Battery Bank (No AC power) 09-24K Btu/h

- Connects to 3 to 12 Panels (\geq Total 870W)
- Runs on Solar Power Only
- 9k, 12k, 18k and 24k Btu/h Cooling & Heating Capacities
- Solar Panels, Heat Pump, and Batteries Hook Directly to Charge Contoller
- Can run up to 8 Hours on battery charge.



All DC Power

The all DC (86) Series is designed for use where AC electrical power is not available, and solar energy is the only available power source. Solar power is used to run the system, and excess generated power charges batteries that are used during overcast weather, or at night. YMGI's (86) Series Solar HP compressor is powered by DC current. The (86) Solar heat pump uses DC power generated by the solar panels or stored in the batteries as needed. By using solar DC power instead of converting municipal AC power, YMGI's (86) Series Solar HP can reduce daytime energy costs for air conditioning or heating by up to 100%.

On bright days, YMGI's (86) Series Solar HP can get 100% of its power from three \geq 300W solar panels. Up to six panels can be connected to the system increasing efficiency, and allowing it to run on 100% solar power even when weather conditions are partly cloudy or overcast. No power is exported by the system, so no special meter or net metering agreement is required.

The (86) system can be installed for hybrid operation by using an AC to DC Converter and municipal power. These installations have solar power providing the energy needed during daylight hours, supplemented by AC power at night or on overcast days.

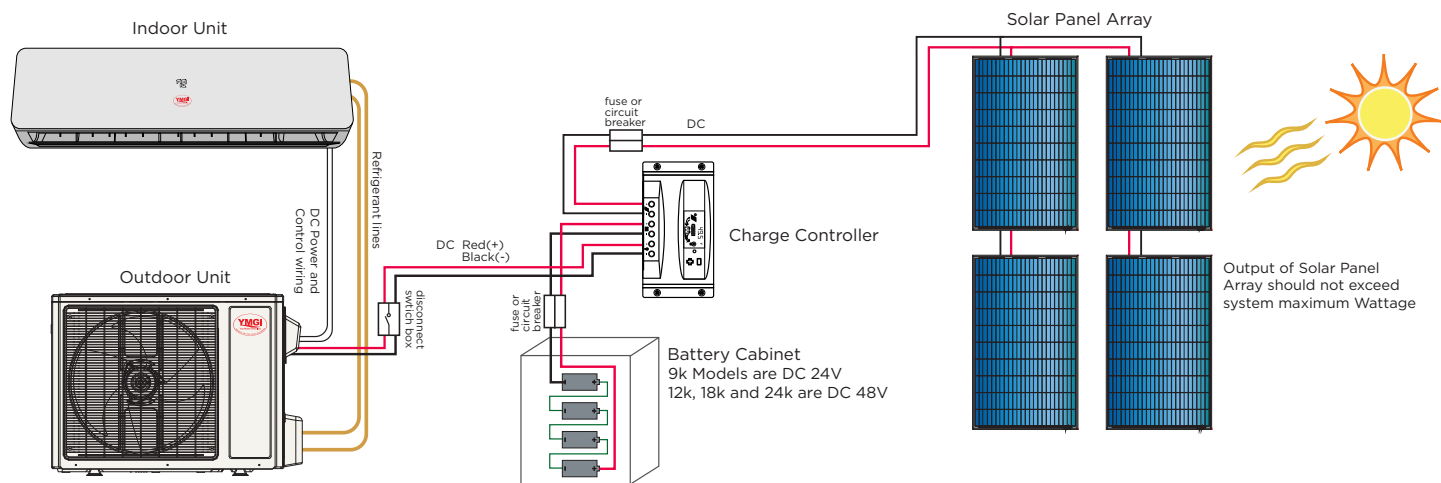

YMGI Group

info@ymgigroup.com • ymgigroup.com

601 Arrow Ln, O'Fallon, MO 63366 • 866-833-3138 | 2883 Atlantic Ave., Brooklyn, NY 11207 • 917-868-4366



Great for Residential and Light Commercial

Heat or cool your home, office, or retail space with little or no energy costs. With capacities of 9k to 24k Btu/h, it can also be used to supplement systems in large homes or buildings.

Ultra-High SEER Solar Air Conditioner and Heat Pump

The (86) Series All DC Mini Split Heat Pump lets you cool your home or office during the day for just pennies or even free. Designed to run completely off solar power, it can also be supplemented with grid power, when solar power can't provide 100% of the energy needed to run your system. The system can use 3 to 12 solar panels, with each panel generating 290 to 360w. When powered by batteries, it can run up to 8 hours, to keep you cool in the evening. There is an option to connect to an AC-DC converter, the high efficiency system will save money while keeping you comfortable without stopping, even when the sun isn't shining.

Simple To Install

The (86) Series Solar Heat Pump unit installs like a standard mini-split, except the installation of solar panels/cables to the unit.

System Model No.	WMMS-09KS-V24(86)	WMMS-12KS-V48(86)	WMMS-18KS-V48(86)	WMMS-24KS-V48(86)		
Indoor Unit Model	WMMS-09ES-V24(86)	WMMS-12ES-V48(86)	WMMS-18ES-V48(86)	WMMS-24ES-V48(86)		
Outdoor Unit Model	WMMS-09CS-V24(86)	WMMS-12CS-V48(86)	WMMS-18CS-V48(86)	WMMS-24CS-V48(86)		
Power Supply to Outdoor Unit + -	24VDC (21V to 27V)	48VDC (42V to 54V)	48VDC (42V to 58V)	48VDC (42V to 58V)		
Performance						
Rated Capacity	Cooling	Btu/h	9000	12000	18000	24000
		W	2600	3500	5000	7200
	Heating	Btu/h	10000	13000	20000	28000
		W	2850	3700	5500	8000
Noise	Indoor	dB(A)	≤40	≤42	≤42	≤46
	Outdoor	dB(A)	≤52	≤52	≤54	≤58
Air Circulation	CFM	265	325	383	500	
EER	W/W	4.56	3.89	3.89	3.89	
	Btu/h/w	15.5	13.33	13.33	13.33	
Batteries		12 VDC x 2	12 VDC x 4	12 VDC x 4	12 VDC x 4	
Suggested Battery AH Minimum	AH	100 x 2	100 x 4	150 x 4	250 x 4	
Suggested Solar Panel Specification		<600w	<800w	<1200w	<1400w	
Refrigerant		R-134a	R-134a	R-134a	R-134a	
Suggested Ambient Temperature Ranges:						
Cooling (capacities/drop/discharge temperatures rise as ambient temperatures rise)	°F	35°F to 110°F	35°F to 110°F	35°F to 110°F	35°F to 110°F	
Heating (capacities/drop/discharge temperatures drop as ambient temperatures go down)	°F	35°F to 60°F	35°F to 60°F	35°F to 60°F	35°F to 60°F	
Power Consumption						
Power Input	W	500	750	1000	1300	
Input Power	V	DC 24	DC 48	DC 48	DC 48	
Rated Current	A	20	16	21	27	
Minimum Circuit Amperage	A	25	20	27	33.75	
Maximum HVAC Circuit Breaker	A	30	25	30	40	
Dimensions						
Indoor Unit (W x H x D)	Unit	in.	30.51" x 10.25" x 8.27"	30.51" x 10.25" x 8.27"	39" x 12.6" x 8.28"	42.125" x 14.57" x 10.25"
	Packaging	in.	33" x 12.8" x 10.4"	33" x 12.8" x 10.4"	42.13" x 15.55" x 11.22"	42.13" x 15.6" x 11.22"
Outdoor Unit (W x H x D)	Unit	in.	31.1" x 21.25" x 10.25"	31.1" x 21.25" x 10.25"	37.4" x 30" x 16.14"	37.4" x 30" x 16.14"
	Packaging	in.	35.83" x 24" x 14.57"	35.83" x 24" x 14.57"	33.46" x 27.95" x 11.81"	33.46" x 27.95" x 11.81"
Solar Panel 305W (W x H x D)	Unit	in.	39 3/8" x 65 1/2" x 1 1/4"	39 3/8" x 65 1/2" x 1 1/4"	39 3/8" x 65 1/2" x 1 1/4"	39 3/8" x 65 1/2" x 1 1/4"
Battery (W x H x D)	12 VDC		100 Ah	150 Ah	200 Ah	250 Ah
	Unit	in.	16 1/2" x 11 x 7 1/4"	9 1/2" x 11 1/2" x 7 1/4"	21" x 11 1/2" x 10"	
Weight						
Indoor Unit	Net/Gross	lbs.	22.046 / 28.66	28.66 / 33.07	33.07 / 37.48	37.48 / 41.89
Outdoor Unit	Net/Gross	lbs.	88.18 / 99.21	99.21 / 105.82	121.25 / 127.87	127.87 / 143.3
Solar Panel	Net/Gross	lbs.	60/62	60/62	60/62	60/62
Battery	Net/Gross	lbs.				

All specifications subject to change without notice. Images are for reference only. See website full details on operation and requirements.

YMGI Group
 601 Arrow Ln, O'Fallon, Missouri 63366
 Phone: 1-866-833-3138
 Fax: 1-866-377-3355
 ymgigroup.com

Sales Representative or Distributor: