



YMGI Group

POB 1559

O'Fallon, MO 63366, USA

Tel: (866)833-3138 Fax: (866)377-3355

Web Site: www.ymgigroup.com

Email: info@ymgigroup.com

Literature Part No: LIT-WMMS-(59)2S-DC IVTR-AM-II-20131130
Subject to Continuous Engineering Improvement without Prior Notice.

YMGI is the Trademark and Property of YMGI Group. Copyright of YMGI Group.



YMGI, Engineered Comfort Products for A Sustainable and Efficient Green World !

INSTALLER'S INSTRUCTION & TECHNICIAN'S SERVICE MANUAL

DC INVERTER MULTIPLE ZONE (59) 2S SYMPHONY CHOIR

OUTDOOR UNIT - 80 & 90CH

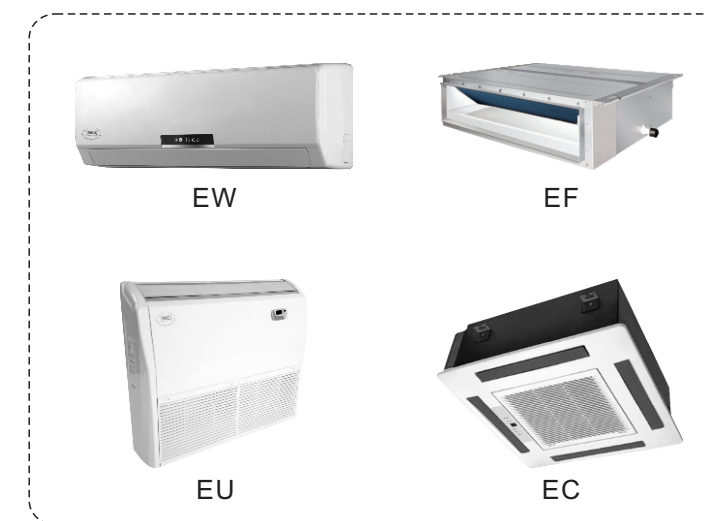

⚠ WARNING

This product is designed and manufactured free from defects in material and workmanship under the normal use and maintenance. Installation, operation, maintenance and service shall follow professional practices for regular cooling and heating equipment, NEC, State, City or Local Codes and related manuals from us. Otherwise, damage to equipment or property even injury to people may occur.

Installer: Currently licensed HVAC installer only, Read this manual before installation. Sign on the warranty registration card.

User: Keep this manual for future maintenance and service use.

Service: Use this manual for service reference.



LITERATURE: LIT-WMMS-(59)2S-DC IVTR-AM-II-20131130

CONTENTS

WELCOME AND PLEASE READ THROUGH MANUALS	2
INSTALLING TECHNICIAN/CONTRACTOR'S JOBS AND RESPONSIBILITIES	4
LIMITED PRODUCT WARRANTY POLICIES	5
LIMITED PRODUCT WARRANTY REGISTRATION CARD	6
WARRANTY AND TECH. SUPPORT	7
ATTENTION FOR INSTALLATION	8
PRODUCT INTRODUCTION	8
SELECTION OF INSTALLATION LOCATION AND PRECAUTIONS	10
INSTALLATION AND SERVICING CLEARANCE	11
INSTALLATION INSTRUCTION	11
INSTALLATION OF REFRIGERANT PIPES	12
ELECTRICAL WIRING WORK	18
DESIGN OF DRAINAGE PIPELINE	20
INSTALLATION OF PROTECTIVE LAYER ON CONNECTION PIPE	20
TEST OPERATION	21
TESTING BOARD INTRODUCTION	21
TROUBLESHOOTING	22
CUSTOMER AND TECHNICIAN MUST READ	25
USER NOTES AND INSTALLATION/SERVICE/MAINTENANCE NOTES	31

WELCOME AND PLEASE READ THROUGH MANUALS

Dear Customer(s)/End User(s)/Unit Purchaser(s)/Installer(s)/Contractor(s):

Thanks for choosing YMGI products.

The YMGI equipment you purchased is either a split-type or a self-contained cooling/heating system which requires an installer's license, certification, knowledge, experience, carefulness and details for a successful and good installation. This equipment is different from those window or portable air conditioners you can normally purchase from local retail stores such as Home Depot, Lowe's, Sears, etc. which the manufacturer may not require licensed personnel to install.

Reading and following the YMGI Group's recommendations, suggestions, and requirements, written in the following pages and other documents, is the first step to ensuring a smooth and trouble free installation & proper operation of your products for many years to come.

The quality of the installation plays a key role in whether the units will work well and for an extended period of time. The information we provide in our manuals is for the sole purpose of reminding you and your installer.

It is our ultimate goal to help insure that your YMGI units are installed properly and correctly from the very beginning to the very end. This ensures that your YMGI units will work well and not only provide a comfortable room but also peace of mind.

⚠ WARNING

YMGI doesn't recommend nor allow any do-it-yourself (DIY) installation (partially or fully), since DIY will cause problems sooner or later to your units and your upfront saving is Not saving down the road.

YMGI warranty doesn't cover any DIY units.

If you have any questions about your unit or even doubt if the unit has any problem, you can first check against the mannds. If you can not find answers, then you can contact your local installer or service technician to physically inspect the unit. If at the time of inspection the installer or service technician have any questions they can contact YMGI technical support division directly at:

Toll Free Number: (866)833-3138

Email: techsp@ymgigroup.com

IMPORTANT NOTE-YMGI HOLDS FINAL EXPLANATION:

YMGI Group, POB 1559, O'Fallon, MO 63366 is the only party who holds the final explanation (in authorized writing) about any descriptions or data in YMGI-published materials, including but not limited to YMGI product brochures, manuals, pamphlets, catalogs, videos and any other media. YMGI's distributors, installers, dealers, agents, customers or any other third parties shall not supersede YMGI to make any explanation about what YMGI-published materials mean. Any uncertainty or questions, arising from YMGI distributors, installers, dealers, agents, customers or any other third parties, should be passed directly to YMGI for an explanation in writing.

⚠ CAUTION All Units Shall Be Installed by Experienced or Licensed Contractor Or Technician. Read Manuals before Installation.

⚠ CAUTION Following NEC, State and Local Codes and Installation Instructions of All Units, Otherwise Unit Warranty Will Be Void and Serious Damage To People Or Property May Be Caused.

⚠ WARNING YMGI Group Will NOT Take Any Responsibilities for Any Damage or Loss Due to Do-It-Yourself(DIY) self-installation and other Improper Installation or Operation or Natural Disaster.

⚠ WARNING Don't Supply Power until All Wiring and Tubing and Checking is Completed. Ground the Unit Following Instructions and NEC, State and Local Codes.

⚠ DANGER Connect All Wiring Securely. Loose Wire or Other Bad Contact May Cause Arc or Overheating and Fire Hazard.



⚠ ATTENTIONS

1. Be sure to hire only one certified, licensed HVAC Company to complete 100% of the installation so that all details of the installation are clear, complete and well taken care of.
2. Be sure to have ONLY the licensed HVAC professional perform all parts of the installation. Factory Warranty will be lost if any portion of the installation is not performed by licensed HVAC contractor. DIY or partial DIY will void ALL factory warranties. One example of partial DIY would be calling the HVAC technician to release refrigerant or the sort while other installation has or is to be conducted by non-HVAC technician.
3. With hiring a technician that is offering their services as a "side job" and not through their licensed HVAC company may pose a possible risk of an incomplete or unsatisfactory installation of no guaranteed workmanship and lack of further service, if needed.
4. Have the installing technician read in full the installation manual of the product model you have. Some details may vary and some may be the key to determine the success and quality of the installation. Experience with certain manufacturer may not be applied fully to another manufacturer. For example, wiring, refrigerant adjustment and trial testing procedures may differ from manufacturer to manufacturer and model to model. Any ignoring or negligence may cause unit failure or damage which could be irrevocable and permanent.
5. All of YMGI's products are fully tested and have passed rigorous safety and performance standards and others related to the industry, before being packed and shipped. YMGI only uses famous brands as suppliers for their parts that are also known for their high quality and performance. The quality of the installation plays a key role as much as up to 90% importance in your unit's overall performance and lifetime. A poor installation can result in unit failure and inefficiency either immediately or over a period of time.
6. Some licensed contractor/technician may make a mistake some time. YMGI doesn't supervise nor is able to control their installation. It is key that the installer take each variable into account during the initial installation in order to ensure a complete and professional installation and properly working units.

⚠ WARNING

The following will cause damage to the unit and key components and the loss of your unit's factory warranty:

1. Any foreign substances introduced into the system as a result of failure of not sealing the ends of the refrigeration piping before pulling through structures at time of installation.
2. Not installing an oil P-trap in the suction copper line where indoor unit is located 18' or more below outdoor unit.
3. Cross piping and/or cross wiring on any units including more than one single zone or a multi zone system.
4. Not conducting a positive leak check by charging the system with dry-nitrogen and soap bubble testing.
5. Not conducting a negative leak check by evacuating the copper lines for 30 minutes. Vacuum must be held at 500 micron or better for at least 5 minutes, starting from 5 minutes after the vacuum pump is shut off.
6. Not conducting a positive leak check prior to the negative leak check.
7. Not selecting the correct size of wire or circuit breaker.
8. Not answering ALL questions in the technician's checklist inside the warranty registration form.

⚠ WARNING

The following may be overlooked, ignored, or treated as not a problem during your installer's installation, but actually will cause your unit to underperform or even cause unit failure.

1. Any kinks or improper bending of the copper piping.
2. Any improper flaring or not centering of the flare with the nut, or not tightening any connection.
3. Not trial testing each indoor unit individually.
4. Not reading technical data (temp/time/pressure/current) after the system is stabilized (normally compressor needs to work at least 10 minutes). Data read too early may lead to inaccurate or false judgment or even a false sense of security.

In an effort to protect our customers from any possible faulty installation which can lead to premature unit failure, we like to provide the above information to you in addition to the technician. You can judge yourself and observe while your system is being installed, though your observation may not be treated as any guarantee whether your system would be installed properly and professionally. If at any time you feel there may be an installation issue, please have your technician contact YMGI at (866)833-3138 x 703 to clear your questions.

- 1) Check with the customers to find out detailed information of structure to be conditioned, local weather (typical design and extreme temperature/humidity conditions, cooling and heating hours), previous and existing HVAC equipment, usage and dependence on the new HVAC equipment or the YMGI products.
- 2) Performing a cooling/heating load calculation by using commercially available professional programs/methods such as Right-J (Manual J) for residential HVAC applications/jobs and Right-CommLoad (ASHRAE RTS/CLTD) for light commercial and commercial HVAC applications/jobs.
- 3) Check with YMGI distributor/sales or contact manufacturer directly to obtain information to fully understand YMGI products, including but not limited to product features, cooling/heating performance-at standard ratings/conditions and extreme conditions, allowed indoor and outdoor temperature/humidity ranges, installation, operation, maintenance, service, warranty, parts and so on.
- 4) Properly select correct (most suitable) YMGI product models (of units and accessories) for your HVAC applications/jobs and list them in your proposal/quote, in writing, on your company's quote form or letter head, basing upon the information you get from 1), 2) and 3) above.
- 5) List your currently valid HVAC license # and EPA # in your proposal/quote.
- 6) Make sure you are the only party to perform the whole installation job and you will not sub-contract any part of the installation to any non-licensed parties/persons. You will be solely responsible for the full installation that you have been contracted for.
- 7) Check to make sure you have all the materials you need to properly and correctly finish the installation. The YMGI units and accessories may be just a portion of what you need. YMGI employees and YMGI distributors/sales, dealers and agents are not installers and may only be able to provide suggestions to you, but you are the only sole decision maker to determine what other materials you must need and/or the customer may want to fulfill the installation job.
- 8) Check against both NEC and your local codes to make sure all the installation of YMGI units and accessories meet these requirements.
- 9) Connect the unit to correct electrical power source. In the area where lightning or storm incurs frequently, a proper type/size of power surge protector needs to be installed between the outdoor unit and power source.
- 10) Select proper types and sizes of HVAC circuit breakers, disconnect switch boxes, wires and conduits from circuit breaker to disconnect box and then from disconnect box to outdoor unit.
- 11) Select proper location to mount indoor units and outdoor units with all factory requirements being followed (cooling/heating/air is not blocked or restricted, mounting structure is secure, aesthetical looking, installation convenience is considered, maintenance/service clearance is ensured and all applicable codes are met and etc.).
- 12) Cap/tape the two ends of every copper line before running them through structures to keep from any foreign substances entering into pipe and causing contamination. Label them A-A, B-B, C-C, D-D, or other marks on each pair of copper line/wiring cable set to keep from any possible cross-piping or cross-wiring in multiple zone installations or where pipes for different single zone systems are close to one another.
- 13) Secure the wiring cables that connect between indoor unit and outdoor unit, following applicable NEC and local codes for your particular installation. If there is no special NEC or local code to govern how these wires are to be installed, you can tape/cable tie them along with insulated copper line.
- 14) Tighten all pipe and wire connections to keep from any possible leakage or false connection.
- 15) Conduct positive pressure leakage checking of inter-connecting copper lines between each indoor unit and outdoor unit by charging dry-nitrogen at outdoor unit service port (note: don't back-seat stopping valve, at this time). Liquid soap solution shall be applied at all pipe connections to check for leakage. A 1/4-5/16" hose/valve adaptor may be needed if you have traditional manifold of 1/4" connection hose.
- 16) If there is no positive leaking, then conduct negative pressure leakage checking of inter-connecting copper lines between each indoor unit and outdoor unit by pulling vacuum at outdoor unit service port (note: don't back-seat stopping valve, at this time) and checking if the vacuum level 500 Micron can be held for at least 20 minutes.
- 17) If there is no leakage found at refrigeration pipe connections, flip up the indoor unit face panel and remove filter, carefully pour some clear water onto the up-right aluminum coil surface to test if the water can drain out of each indoor unit freely without any leakage being found.
- 18) If there is water leakage found, locate the source of the leak and correct. Only after everything is clear engage the correct electrical power to the system.
- 19) Then back-seat stopping valves of outdoor unit to release refrigerant from outdoor unit into inter-connecting pipes and indoor unit.
- 20) Check to make sure both indoor unit and outdoor unit are powered on correctly before controlling the indoor unit to operate in fan mode first. Then move on to test cooling, dehumidifying/drying, heating and other modes.
- 21) Read refrigerant pressures and pipe/valve temperatures only until the system is stabilized (normally 10 minutes after cooling/heating mode is started successfully). Put this data into the technician checklist in the lower half section of the Limited Product Warranty Registration Card/Form.
- 22) Adjust refrigerant charging level (remove refrigerant if pipe is shorter/temperature is colder; add refrigerant if pipe is longer/temperature is warmer), following manufacturer's instructions, if average pipe length is shorter or longer than 25' and pressure/temperature readings at outdoor unit service valves are not falling into normal ranges.
- 23) Explain to the user/owner(s) about proper unit operation and maintenance and leave your contact information for them to reach you easily.
- 24) If the customer finds the unit doesn't work properly and cannot resolve the issue themselves, check the customer's units/parts/accessories and correct the problem if there is any. Communicate with YMGI-technical support line (866)833-3138 x 703, if needing help.

Following these requirements will aid in ensuring the units to be installed to the general HVAC practicing standards and necessary factory requirements, finding any possible problems early, preventing any further damage to the unit and helping ensure a properly working unit over its lifetime.

LIMITED PRODUCT WARRANTY POLICIES

The YMGI products are designed and manufactured free from defects in workmanship, and materials for normal use. However, for any reason, including many handlings and occasions between the YMGI factories/warehouses and where you receive the products, the unit doesn't work, YMGI Group will help to remedy the occurrence in the following warranting ways:

Compressor: YMGI will warrant the compressor of YMGI-validated and approved warranty filing, for a period of 5 years from the date of successful installation at original location.

Parts: YMGI will warrant parts of YMGI-validated and approved warranty filing, for one year from the date of successful installation at original location.

All warranty compressors and parts replaced will become the sole property of YMGI Group and must be returned to YMGI Group upon request. Warranty parts may be new or refurbished. All parts are tested and approved before shipping.

At no time does the YMGI Group warrant labor cost of any type. Warranty will start from the date of successful installation at initial location, or 90 days as of original shipping date from YMGI Group, whichever comes first.

This is a standard warranty of limited liability and DOES NOT cover the following:

- * Any damage or repairs to properties, or persons as an incident or consequence of improper or faulty transportation, installation, operation, maintenance or service.
- * Damage caused by frozen or broken water hoses or refrigeration pipes in the event of equipment failure.
- * Any damage as a result of floods, fire, wind, lightening, accidents, corrosive atmosphere or any other conditions beyond the control of YMGI Group.
- * Any damage due to interruption or inadequate electrical service to equipment.
- * Any products that are installed outside the US or Canada.
- * Any unit that has been moved from the original installation address.
- * Any labor costs associated with the installation or service of the unit.
- * Poor unit performance due to improper unit selection (SEER, Unit size).

To validate the above warranties, ALL the following conditions must all be fulfilled:

1. The unit was fully (100%) and successfully installed by licensed or certified HVAC technicians.
2. The unit was installed following all NEC, state and local codes.
3. The unit was installed following all instructions and manuals made by YMGI Group.
4. ALL fields, especially the technician-checklist, of the **Limited Warranty Registration Card/Form** were filled completely by the installing technician and signed by both the installing company technician and the unit owner.
5. The **Limited Warranty Registration Card/Form** and a copy of the original installing company's invoice had been received by YMGI Group-Warranty Dept., POB 1559, O'Fallon, MO 63366, within 7 days of successful installation.

No warranty filing will be validated or approved, if any one of the above 5 conditions is not met.

Product registration doesn't guarantee the validity of this limited warranty statement.

Steps to follow for warranty part replacement:

1. Installing or service technician contacts YMGI tech support at 1-866-833-3138 ext 703 from the jobsite, to double-check and confirm with YMGI Technical support the exact part(s) needed to fix all the problems.
2. YMGI will check the customer's warranty filing. Parts for validated and approved warranty will not be charged. Parts of invalid warranty filing or unapproved warranty requesting, will be charged accordingly.
3. YMGI will ground ship out the parts ASAP. Expedited shipping is available at the customer's cost.
4. Replacement parts of approved warranty registration are to be warranted for the remainder of the 1 year parts and 5 year compressor warranty. Purchasing of replacement parts of invalid warranty filing or unapproved warranty requesting, will be as they are and bear no warranty.

YMGI keeps on improving products with various engineering changes without prior notice. Such improvements or changes include but not limited to product specification, appearance, functions, sizes, packaging and others. These improvements or changes will not void the limited warranty stated herein. YMGI keeps the final explanation of this warranty policy.

LIMITED PRODUCT WARRANTY REGISTRATION CARD

 YMGI GROUP <small>Innovative, Competitive, Efficient & Convenient</small>		LIMITED PRODUCT WARRANTY REGISTRATION CARD / FORM	
YMGI to Fill Top Portion, at Shipping, and Keep Copy A; Center Copy B for Installer to Fill and Mail back to YMGI; Bottom Copy C for Customer to Fill and Keep			
For YMGI Use Only	The Company the Unit Was Sold Through: _____		Shipping Packing List Number: _____
	Did the Company Pay to YMGI: _____		HVAC Contractor/Technician--Name: _____
	Installation Invoice Attached to the Registratio Card _____		Hired YMGI-Recommended HVAC Contractor/Technician? _____
		Registration Card Serial No. _____	Date the Filled Registration Card YMGI Received: _____
		Unit(s) Work Successfully (Yes/No): _____	Warranty Approved _____ Warranty Denied _____
Outdoor Serial Number (One Outdoor Unit, One Registration Card/Form): _____		Indoor Serial Number: _____	For Multi Zone Units _____
		Unit #1 _____	Unit #5 _____
		Unit #2 _____	Unit #6 _____
		Unit #3 _____	Unit #7 _____
		Unit #4 _____	Unit #8 _____
Contact Where the Units are Installed: Name: _____ Phone: _____ Fax: _____ Address: _____ Email: _____ City: _____ State (Province): _____ Country: _____			
Contact of the Installing HVAC Contractor/Technician: Technician Full Name (Print): _____ HVAC Technician's Company Name: _____ Address: _____ Currently Licensed or Certified HVAC Technician License or Certification Number: _____ Official Phone # to Check the License Validity: _____		YMGI-Recommended Contractor/Technician: Phone/Fax: _____ Email: _____ City:State (Province): _____ License Approved or Certified by: _____	
List for Installing HVAC Technician to Double Check Installation Quality, and Warranty Processing Purpose (if not filled by technician, or not filled fully, warranty will void)			
1) Are you the only one to install whole system? If not, % of installation done by you (HVAC technician).		2) What had been done, prior to your arrival?	
3) Did you read the User Manual and Installation Instruction, before you started the installation?		4) Who unpacked the unit and accessory boxes to check for damage?	
5) Supply electrical power V/Ph/Hz measured at wiring terminal block of Indoor unit: _____ outdoor unit: _____		6) Incoming electrical power V/Ph/Hz measured at terminal blocks of indoor unit: _____ outdoor unit: _____	
7) Wire gauge, length and terminal colors between circuit breaker/ disconnect switch to outdoor unit: _____		8) Wire gauge, length and terminal colors between each indoor and outdoor unit: Unit A _____ Unit B _____ Unit C _____ Unit D...	
9) The size of HVAC circuit breaker/fuse or disconnect switch to the outdoor unit: _____		10) Are the inter-connecting wires and copper lines between indoor and outdoor units installed/covered/protected by line set covers, or anything else?	
11) What is the refrigerant pipe length between each indoor unit and the outdoor unit? Unit A _____ Unit B _____ Unit C _____ Unit D...		12) Where is/are the indoor unit(s) located? Unit A _____ Unit B _____ Unit C _____ Unit D...	
13) What is the elevation difference between each indoor unit and the outdoor unit? Unit A _____ Unit B _____ Unit C _____ Unit D... (indoor unit above outdoor unit +, below -)		14) Did you check the indoor unit for condensate leakage and refrigerant leakage, before and after connecting them?	
15) Where is the outdoor unit located? Ground wall balcony roof other _____ Is the outdoor unit anchored to ground or secured onto wall location or pad _____ bracket?		16) Have you checked to make sure there is no cross-piping and no cross-wiring between any two indoor units (zones)? How did you do it, who was with you?	
17) Were the refrigerant pipe ends capped or taped seal, prior to running them through structures to keep debris from entering the copper lines?		18) Have you checked and run cooling or heating, one unit by one unit, all working fine?	
19) Did you charge the inter-connection copper pipes and indoor unit with nitrogen to check for positive leakage (pressures 150-200PSI), before conducting vacuuming leakage check?		20) Did you vacuum correctly to check the connecting pipes and indoor unit for leakage, what was the micron gauge reading, for how many minutes?	
21) Did you check if the compressor can be started and stopped in a correct (design) manner?		22) If copper length were not made to the supplied or recommended refrigerant pipe length, how much refrigerant added or deducted?	
23) Measured refrigerant pressures at outdoor service suction valve, when unit was st. Heat pump (PSI): _____ Cooling (PSI): _____ Outdoor Ambient Temp. (°F): _____		24) What were the measured temperatures (probe not touching any metal): At cooling: indoor return air °F, discharge air °F, and outdoor °F At heating: indoor return air °F, discharge air °F, and outdoor °F	
25) Have you checked all unit functions, with customer's witness, and all functions are correct?		26) Did you show the user how to operate the unit? Did he/she understand you?	
27) Do you provide regular one-year free technical service for this installation?		28) Do you list the working details in the invoice and leave a copy to the customer?	
Installation Finished and Unit Works Successfully. Print Name of Installation HVAC Technician: _____ Signature: _____		Installation Finished and Unit Works Successfully. Print Name of Owner: _____ Signature: _____	
Date and time: _____		Date and time: _____	
By signing above, I acknowledge the liability and responsibility for any false statement or not telling all the facts, and I authorize YMGI to check the details of the filled above, and make its decision on warranty. I understand our filing or filling the warranty card/form DOESNT mean automatic warranty approval, because warranty is approved only to those qualified and successful installations by qualified HVAC technician. I know the warranty, if approved, is a standard 5-year compressor and 1-year other parts only, without any labor coverage. I agree to and will follow all the contents contained in the Limited Product Warranty Policy that YMGI, not other entity, stated in public, including but not limited to manuals, web site, email, etc.			
Important Note: A copy of the installing HVAC company's invoice to show all their work details, your payment proof, center copy B of this registration card filled after a successful installation, all three (3) MUST be mailed together to Warranty Dept., YMGI Group, POB 1559, O'Fallon, MO 63366 , for warranty processing. Customer keeps bottom copy C. YMGI will check against copy A that was kept at YMGI.			



WARRANTY AND TECH.SUPPORT

YMGI warrants to the purchaser/owner(s) that YMGI products be free from defects in material and workmanship under the normal use and maintenance, with the standard Limited Product Warranty Policies that comes with the unit or sales package.

YMGI IS NOT RESPONSIBLE FOR

- * Damage or repairs required as a consequence Customer do-it-yourself(DIY) installation and/or any other faulty installation or improper application.
- * Damage or repairs needed as a consequence of any misapplication, abuse, improper servicing, unauthorized alteration, or improper operation.
- * Damage as a result of floods, winds, fires, lightening, accidents, corrosive atmosphere, or other conditions beyond the control of YMGI.
- * Any damages to person or property of whatever kind, direct or indirect, special or consequential, whether resulting from use or loss of use of the product.
- * Failure to start due to voltage conditions, blown fuses, open circuit breakers, or other damages due to the inadequacy or interruption of electrical service.
- * Parts not supplied or designated by YMGI.
- * Products installed outside USA or Canada.
- * Regular equipment maintenance or field service or field inspection.
- * Any problems due to improper cooling and heating load calculation of the room/building the air conditioner/heat pump system is to be installed. Equipment users can get the calculation schedule from your room/building architect or your installation or related service HVAC contractor, who should have the knowledge and the tools to do these calculations correctly.
- * Any problems due to improper sizing and selecting air conditioner/heat pump system. These equipment sizing and selection work should be conducted by either your room/building architect or your installation or related service HVAC contractor, who should have the knowledge and the tools to do these calculations correctly, and get your approval, before purchasing the air conditioner or heat pump equipment.
- * Any problems due to improper installing of the air conditioner/heat pump system. Installation should be conducted by currently licensed HVAC technician, following manufacturer installation instructions, all governing safety codes, with care and professionalism.
- * Any problems due to improper operation of the air conditioner/heat pump system. Users shall keep the manual and refer to it for the correct understanding of how the unit will work and how to operate the unit correctly.
- * Any problems due to improper maintenance of the air conditioner/heat pump system. Like a car, regular maintenance or yearly checking is necessary for the unit to work properly for you, before the season comes. For example, air filter shall be checked for cleanliness from time to time. Remote control batteries shall be checked for enough power, before judging the unit is not working...

CONTACT FOR FIELD SERVICE OR REPAIR

The following people, in a prioritized sequence, will take care of your request or issue:

- 1) The original installer; otherwise,
- 2) Your current service contractor; otherwise,
- 3) Authorized contractor in YMGI list that is close to you; otherwise,
- 4) Authorized Distributor in YMGI Distributor list; otherwise,
- 5) Contractor/Distributor you prefer who is close to you.

CONTACT FOR GENERAL TECHNICAL QUESTIONS OR SUPPORT, IN A SEQUENCE:

- 1) The original installer; otherwise,

- 2) The current service contractor; otherwise,

The original licensed installer or current service contractor should be contacted first of all, since they installed the unit and/or know more details than anybody else.

They will check the unit and find out the problems with the professional knowledge about HVAC and electric product installation by using special tools or instrument.

They can contact YMGI technical support for technical help during unit installation or inspection.

Product model and serial numbers needed, which can be found on unit nameplate sticker, so that our technician can quickly identify the unit, parts and wiring diagrams, among our many products and models.

- 3) The distributor; where the unit is purchased from otherwise,

- 4) YMGI Technical Support:

Tel: (866) 833-3138*703 Email: techsp@ymgigroup.com

ATTENTION FOR INSTALLATION

PRECAUTIONS FOR R410A

- * It is very strict that the refrigerant pipes should be clean and dry.
- * The R410A is a mixed refrigerant, when add the refrigerant to the unit, it must keep the refrigerant in its liquid state. If the refrigerant is in gas state, the composition has been changed and the capability of the unit will decrease.
- * When the refrigerant is leak out, please do not touch the leakage. Otherwise, it will result in frostbite.
- * It does not support to let a lot of refrigerant go into the ambient atmosphere, because it will strengthen the green house effect. Otherwise, it will produce toxic gas when the refrigerant contacts with the fire.

PRECAUTION FOR INSTALLATION

- * The unit is more than 240 lbs, so more than two people will be needed to move the unit.
- * Do not lift by packaging.
- * When removing packaging, place the hands on the corners and be careful not to cut hands on the fins.
- * Dispose of the packaging to in a garbage bin after the installation.

PRECAUTION FOR OPERATION TEST

In order to protect the compressor from vibrating during transportation 2 metal gaskets are used. They must be removed prior to commissioning and retighten the nuts firmly; otherwise the unit may not operate well.

ACCESSORIES

The accessories of the unit, please look out the Packing List in the package.

PRODUCT INTRODUCTION

The YMGI Super Any Match System adopts inverter compressor technology. According to change displacement of compressor, stepless capacity regulation within range of 10%~150% can be realized. Various product line-up is provided with capacity up to 90,000 Btu, which can be widely used in residential, light commercial, institutional and some industrial applications with variable load change. YMGI commercial air conditioner is absolutely your best choice.

NAMES OF MAIN PARTS

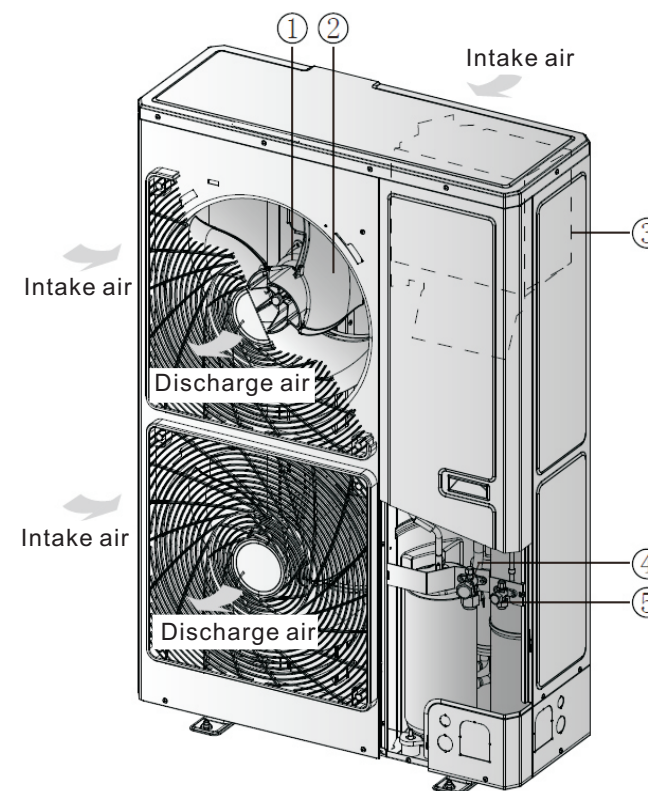

NO.	①	②	③	④	⑤
Name	Fan motor	Axial flow fan blade	Electrical box	Gas side stop valve	Liquid side stop valve

COMBINATIONS FOR OUTDOOR AND INDOOR UNITS

Sorts		WMMS-80CH -V2B(59)2	WMMS-90CH -V2B(59)2
No. of indoor units to be connected	Min	2	2
	Max	8	9
Total capacity of indoor units to be connected(Btu/h)	Min	24000	28000
	Max	80000	90000

PRODUCT INTRODUCTION

PARTS AND COMPONENTS OF UNIT

For the super free match series system, one outdoor unit is able to drive up to three BU modules and nine indoor units which include EC, EF, EW, and EU.

The outdoor unit will run as long as any one indoor unit receives the running command, and all indoor units stop once the outdoor unit is turned off.

SYSTEM LAYOUT EXAMPLE(3 BU BOXES)

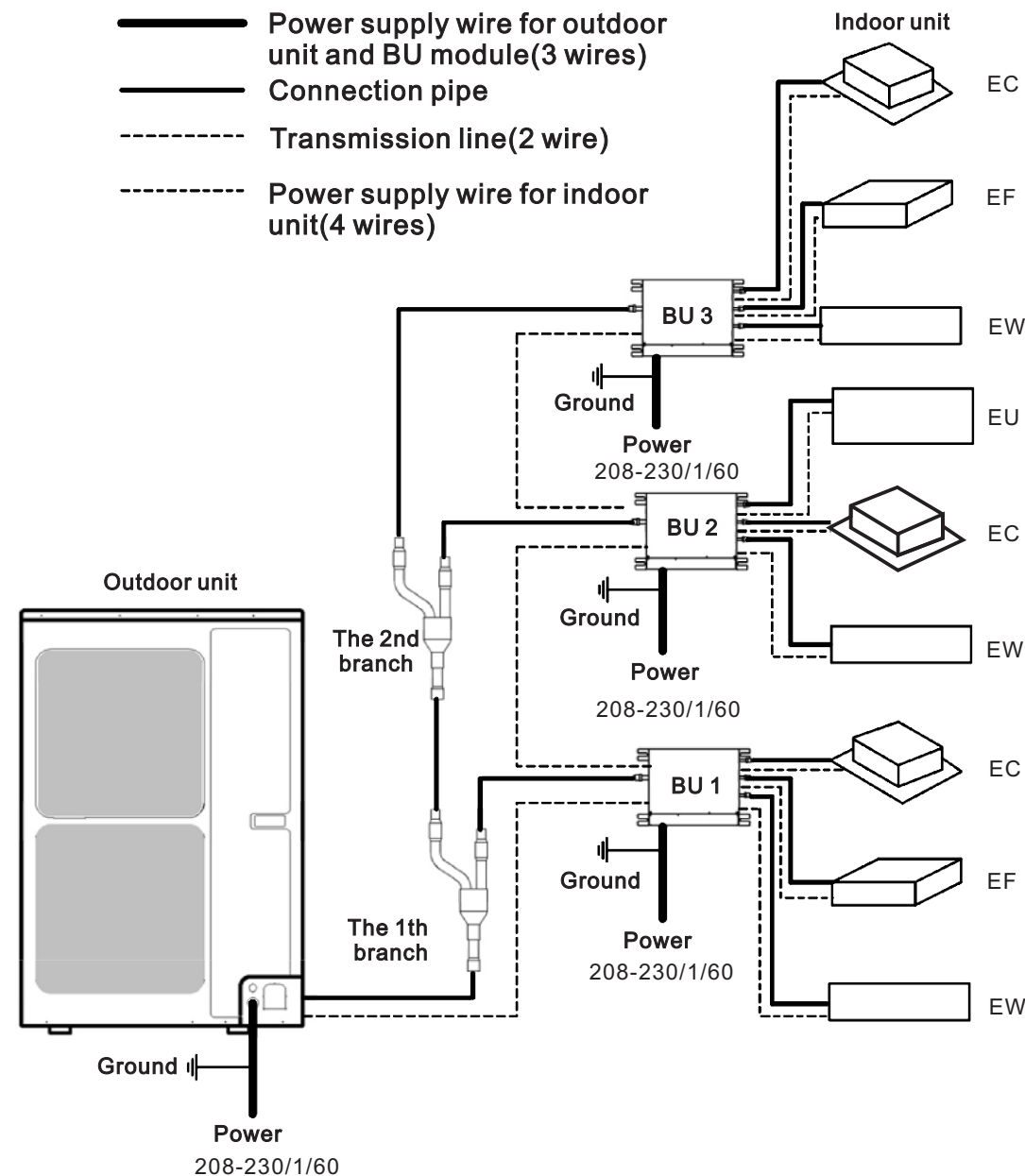

WORKING TEMPERATURE RANGE

Items	Outside temperature DB/WB (°F)
Maximum cooling	118 / NA
Minimum cooling	5 / NA
Maximum heating	81 / NA
Minimum heating	-4 / NA

SELECTION OF INSTALLATION LOCATION AND PRECAUTIONS

- * The installation of the air conditioner must be in accordance with the national and local laws and regulations.
- * The quality of the installation will affect the capability of air conditioner directly. The installation should be left to the appointed service center. Please contact your dealer after purchasing this machine. Professional installation workers will provide installation and test services according to the installation manual.
- * The air conditioner should not install in this place where the small animals exist, because they may cause malfunctions, smoke or fire. Please keep the area around the unit clean.

SELECTION OF INSTALLATION LOCATION

- * The outdoor unit must be installed on a firm and solid support which can withstand the weight and the mounting surface must be horizontal plane.
- * There is enough space for the installation and maintenance.
- * The place should be well-ventilated, so the machine can absorb and discharge sufficient air.
- * Outdoor unit shall be installed close to the indoor unit, hence to minimize the length and bends of cooling pipe.
- * Avoid place the outdoor unit under the windows or between the constructions, hence to prevent normal operating noise from entering the room.
- * Do not install in the place where there is flammable or explosive gas exist or a place subject to severe dust, salty fog and polluted air.

Installation at the following places might lead to the air conditioner malfunction. If it is unavoidable, please contact the appointed service center.

- * A place which is full of machine oil;
- * A region with saline-sodic soil near the sea;
- * A place where the sulphide fog exists, such as the sulphur spring;
- * A place where the high frequency facilities exist, such as radio equipment, electric welder and medical equipment;
- * An environment with special conditions.

OUTLINE DIMENSION OF OUTDOOR UNIT

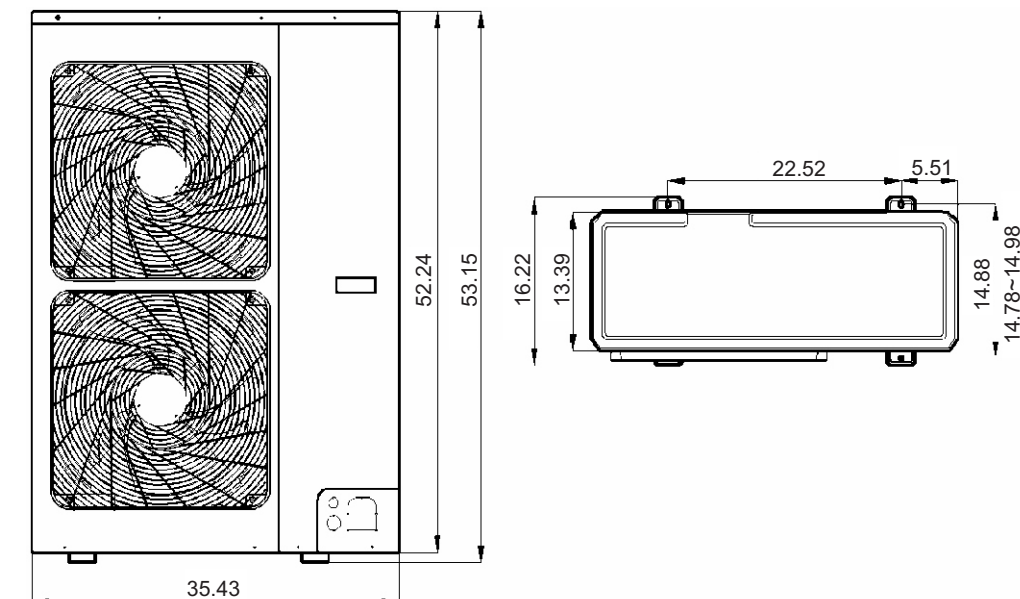

INSTALLATION AND SERVICING CLEARANCE

1) When the place of the installation is exposed to strong wind

When strong winds of 5 m/sec or more exist in the place of the installation, the outlet of the unit cannot face the wind. If the wind blows against the outdoor unit's air outlet, it will cause deterioration of the operational capacity and maybe break the fan.

2) In case of installing only one unit

In case obstacles exist around the unit, the required installation space is in the Fig. 1.

3) In case of installing multiple units(2 units or more)

In case multiple rows of series installation, the required installation space is in the Fig. 2.

INSTALLATION AND SERVICING CLEARANCE

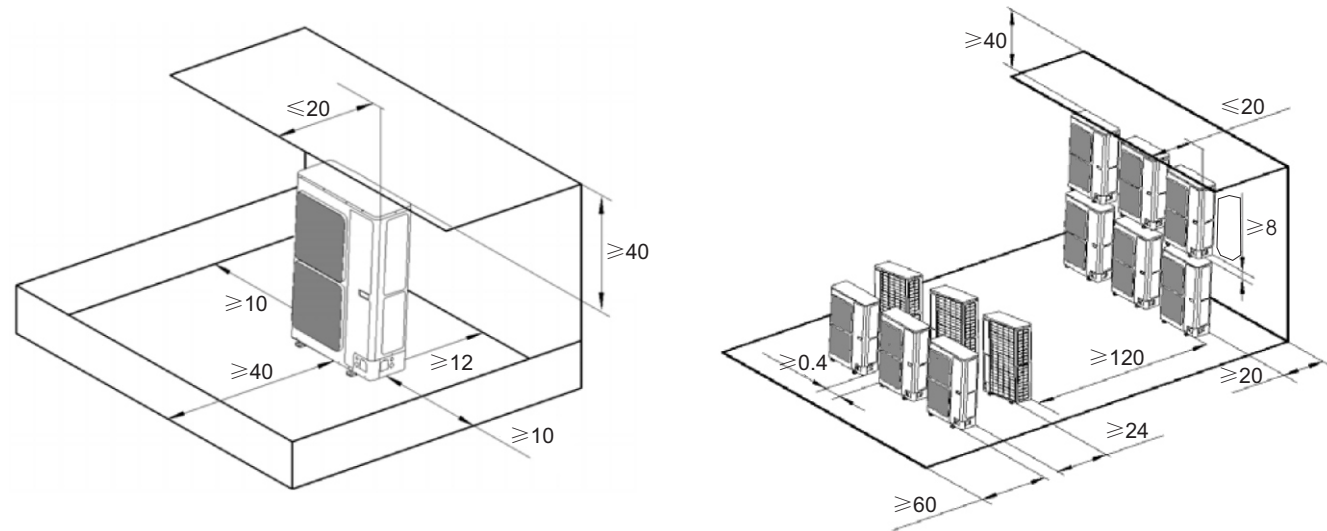

INSTALLATION INSTRUCTION

- 1) Check the installation location and ensure it is strength and level, so that the unit will not cause any operating vibration or noise after installation.
- 2) In accordance with the foundation drawing in the Fig. 6, please drill 4 holes in the installation location.

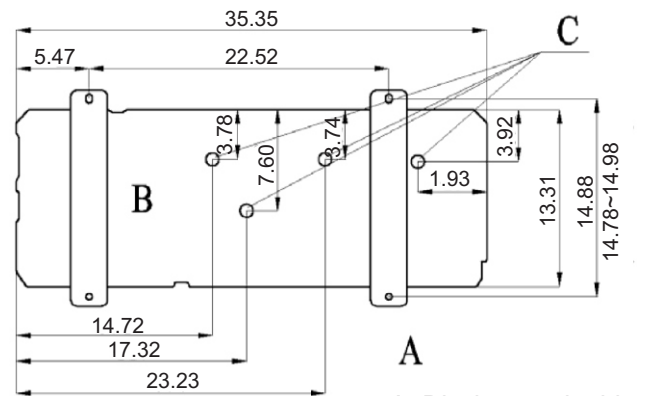

A: Discharge air side
B: Bottom view (inches)
C: Drain holes

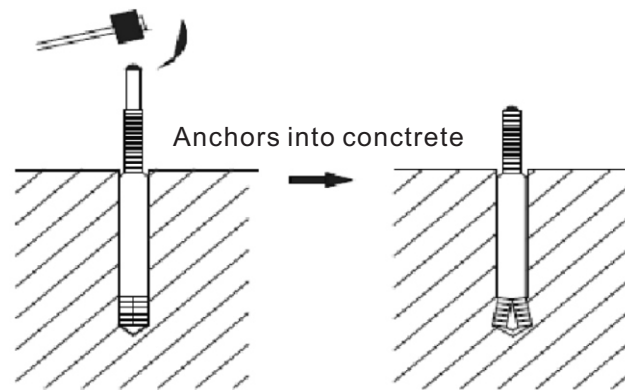

- 3) Fix the unit securely with the foundation bolts. You can get the M10 or M8 foundation bolts, nuts and washers from the market.
- 4) Rubber or spring shock absorbers should be used during the installation of the outdoor unit to meet the noise and vibration requirements.
- 5) Screw the foundation bolts into the ground, and it is better that their length is less than 0.79in from the foundation face.

INSTALLATION OF REFRIGERANT PIPES

MANIFOLD MODE OF CONNECTING PIPE

- 1) For only one BU module, there will not be more than three indoor units.

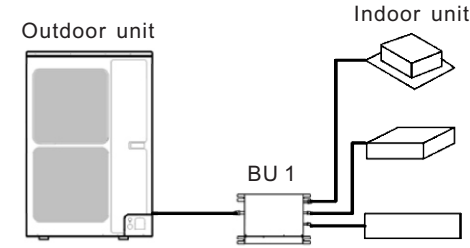

- 2) For two BU modules, there will not be more than six indoor units.

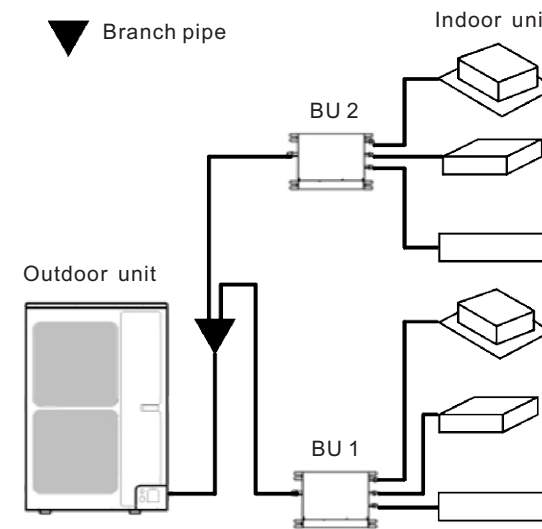

- 3) For three BU modules, there will not be more than nine indoor units.

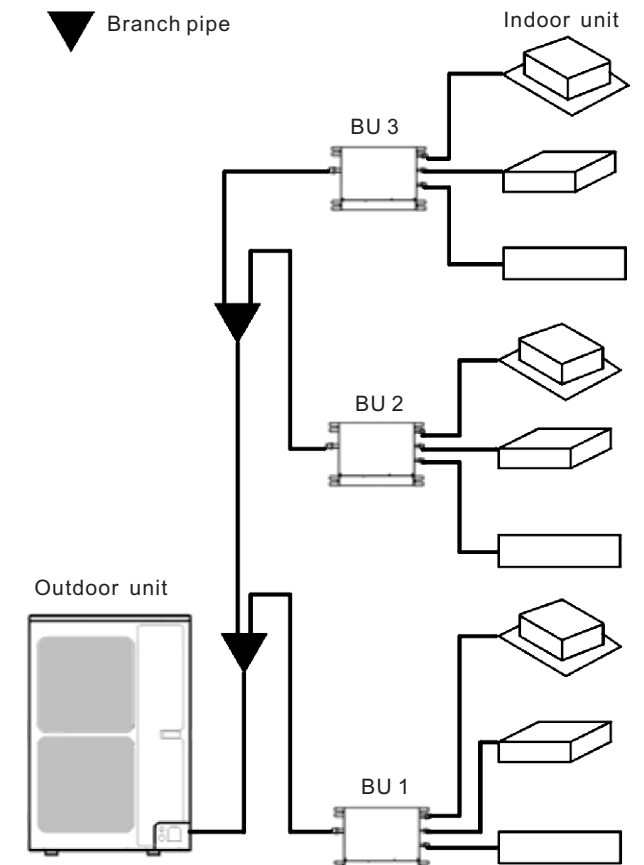

ALLOWABLE LENGTH AND DROP HEIGHT OF CONNECTING PIPE

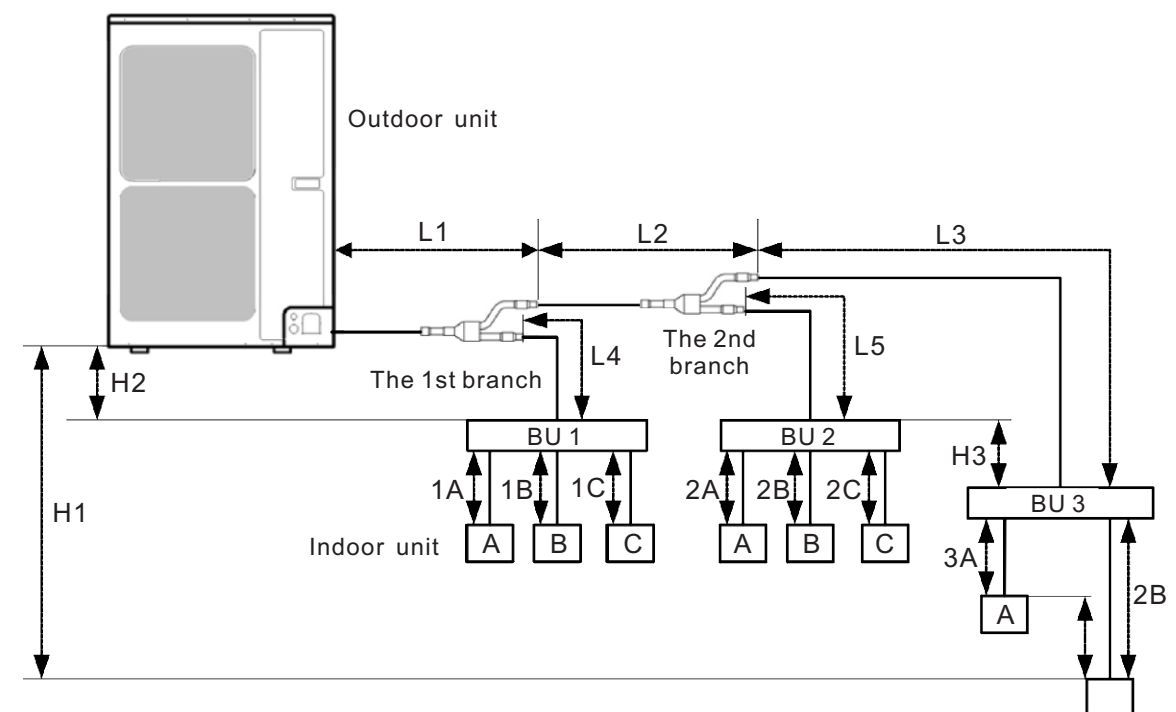

INSTALLATION OF REFRIGERANT PIPES

Items	The pipes	Length (Ft.)	
Maximum allowable length	Between outdoor unit and BU	L1+L2+L3+L4+L5	≤180
	Between indoor unit and BU	WMMS-80CH-V2B(59)2	≤262
		WMMS-90CH-V2B(59)2	≤295
	Between indoor unit and BU module	1A;1B;1C;2A;2B;2C;3A;3B	≤49
Between indoor unit and the 1st branch	L4+1B;L2+L5+2A; L2+L3+3B	≤131	
Maximum allowable length	Between outdoor and indoor units	H1	≤98
	Between outdoor units and BU	H2	≤98
	Between BU and BU modules	H3	≤49
	Between indoor and indoor units	H4	≤49
Minimum allowable length	Between outdoor and the 1st branch	L1	≥16
	Between BU and the branch	L3;L4;L5	as possible as short

DIMENSIONS OF CONNECTING PIPES

Items	Gas Pipe (inch)	Liquid Pipe(inch)
Capacity of indoor unit(Btu/h)	9000, 12000	3/8
	18000	1/2
	21000, 24000	5/8
BU module	Connecting to Indoor unit (I.D)	5/8
	Connecting to Outdoor unit (I.D)	3/4
Outdoor unit	WMMS-80CH-V2B(59)2	5/8
	WMMS-90CH-V2B(59)2	5/8
Between outdoor unit and the 1st branch	The pipe L1	3/4
Between the 1st and the 2nd branch	The pipe L2	5/8

CONNECTION OF BRANCH PIPES

If two or three BU modules used, Y-type branch pipe of (59)2S-00-BranchY will be chosen

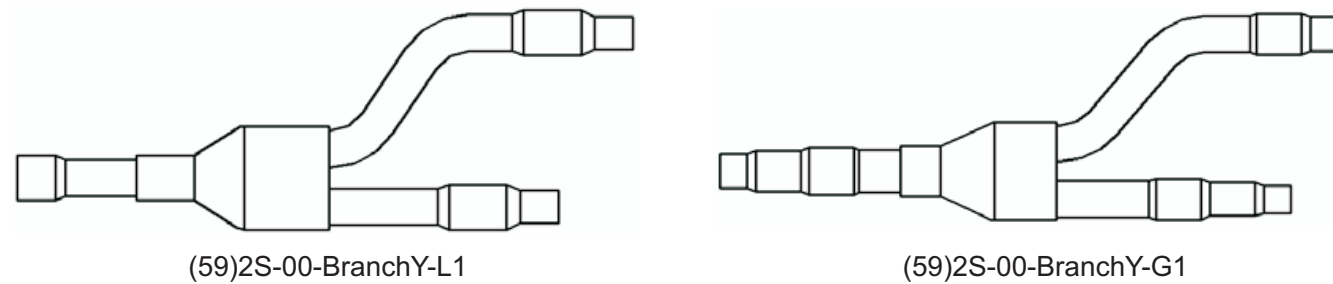

Y-type branch pipe is equipped with auxiliary tubes to adjust the diameter of different pipes. If the dimension of the pipe selected is different from the dimension of branch pipe joint, Cut the copper tube in the middle with tube cutter and clear up burrs. Please do that as following figure.

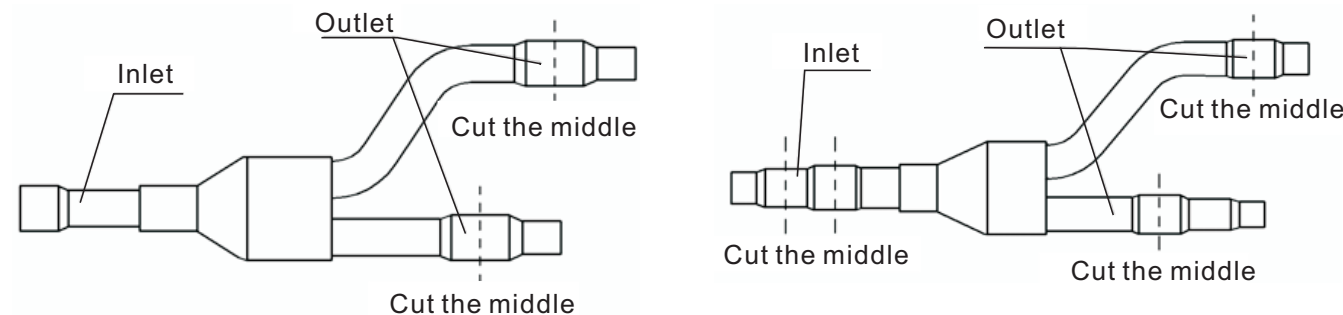

INSTALLATION OF REFRIGERANT PIPES

Y-type branch pipe must be installed in vertical or horizontal direction. In the inlet of the branch pipe, keep at least 19.69inch straight pipe.

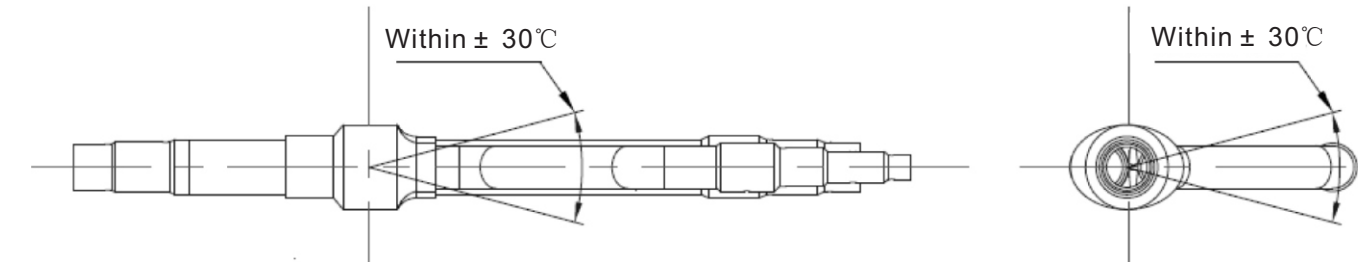

PRECAUTION FOR CONNECTION

- Pipe connections should follow the following rules:
 - Outdoor unit shall be installed close to the indoor unit, hence to minimize the length and bends of connection pipes.
 - The gap of outdoor unit and indoor units should be as small as possible.
 - The bending diameter of the pipeline is better as large as possible.
- The brazing operation must be strictly in accordance with the process requirements. During the installation, do not damage the pipeline and the bending diameter must be greater than 200mm.
- The connection pipe cannot often be bent or straightened. Otherwise it will harden.
- The elbow operation must use the elbow. Otherwise, the pipe may be cracking.
- The process of flaring
 - Using the tube cutter cutting the connecting pipe in the middle and remove the burrs.
 - Install the nut before the flaring operation.
 - Check the flared portion, whether there is fractured or not.
- The following table for the torque required to tighten the nuts.

Pipe diameter(inch)	Wall thickness(inch)	Tightening torque(N.m)
0.25	≥0.02	15~30
0.375	≥0.03	30~40
0.5	≥0.04	45~50
0.625	≥0.04	60~65
0.75	≥0.04	70~75

- Align the flared end of copper tube with the center of pipe joint. Tighten the nuts with hands.
- Tighten the flaring nuts with torque wrench until you hear a "click".

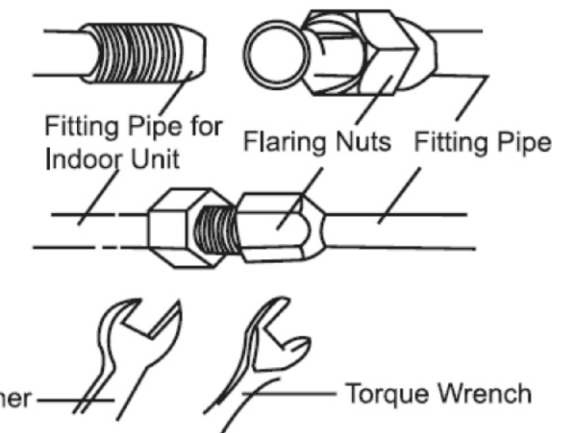

- After all the refrigerant installation has been done, use nitrogen to carry out gas leak check.
 - During the connection of the indoor unit or BU module to the refrigerant pipe, never pull any joints of the indoor unit or the BU module by force; otherwise the capillary pipe or other pipe may crack, which then would result in leakage.
 - The refrigerant pipe should be supported by brackets, that is, don't let the unit withstand the weight of it.
 - For the Super Free Match system, each pipe should be labeled to tell which system it belongs to avoid mistaken inaccurate piping.

INSTALLATION OF REFRIGERANT PIPES

CONNECTION OF REFRIGERANT PIPE

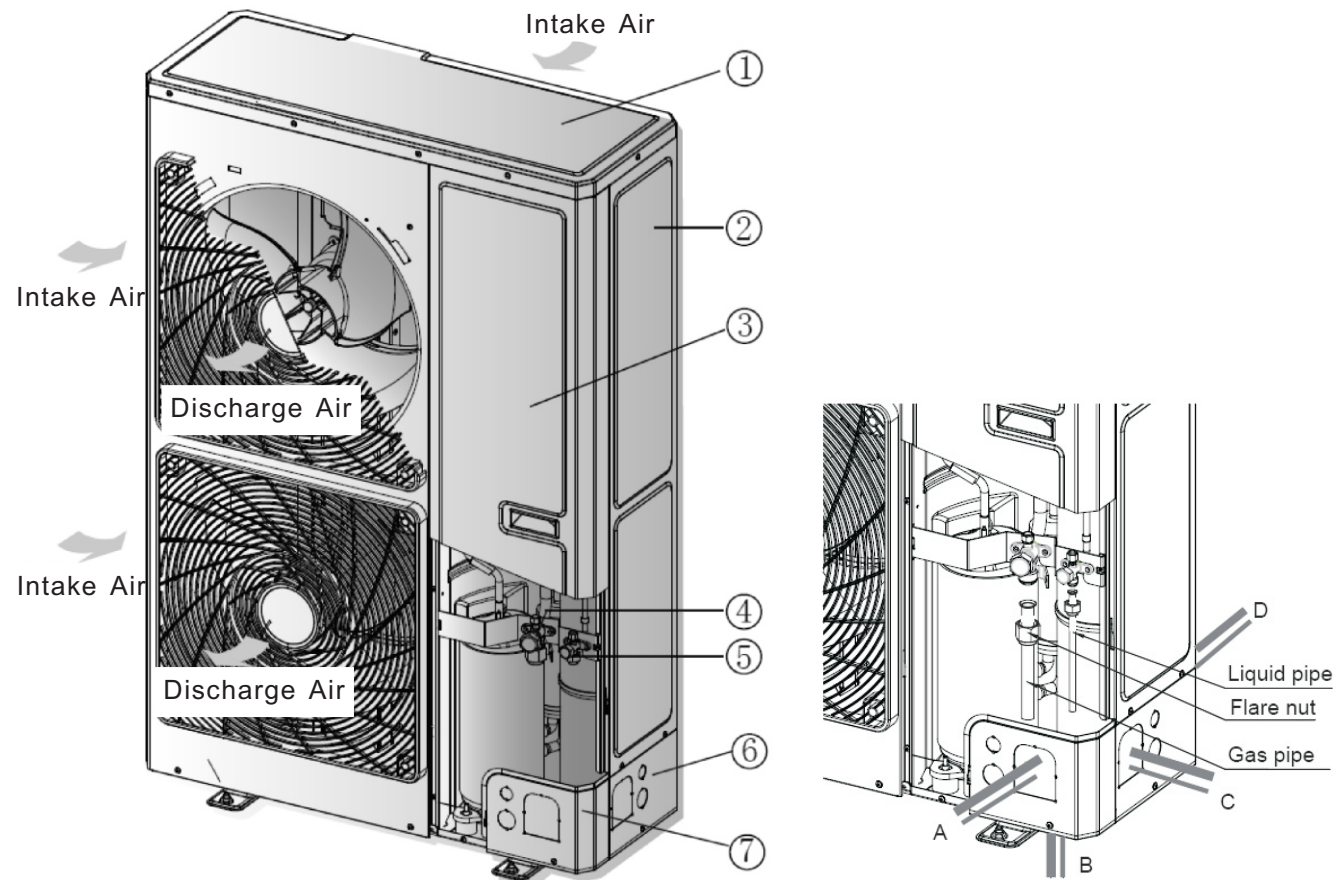

NO.	①	②	③	④
Name	Coping plate	Rear side plate	Front side plate	Gas side stop valve
NO.	⑤	⑥	⑦	
Name	Liquid side stop valve	Right connection board	Front connection board	
NO.	A	B	C	D
Name	Front connection	Bottom connection	Side connection	Rear connection

- 1) Unscrew the coping plate, front side plate, right connection board and front connection board.
- 2) The refrigerant pipes can be installed in four directions, please choose the proper direction.
- 3) Knock the holes in the plate of the chosen direction with the drill and hammer.
- 4) Connect the pipes to the stop valves.
- 5) Bend the pipes to go through the knockout holes.
- 6) Cover the through-holes with sealing materials to prevent the water, dust or small animals going into the outdoor unit.

LEAK TEST

- 1) Please make sure that the stop valves of the outdoor unit are closed during the operation.
- 2) The leak test should be made by pressurizing nitrogen gas.
- 3) Open the pressure reducing valve, pressurize the connection pipes to 1.0 MPa (145 PSI) slowly, wait ten minutes, and make sure that the pressure will not drop.
- 4) Rise the pressure to 2.0-4.0 MPa (290-580 PSI) slowly, wait 24 hours, and make sure the pressure will not drop.
- 5) If the pressure does not decrease, the pipes have passed the test. Otherwise, look for where the gas leaks from.

INSTALLATION OF REFRIGERANT PIPES

VACUUM OPERATION

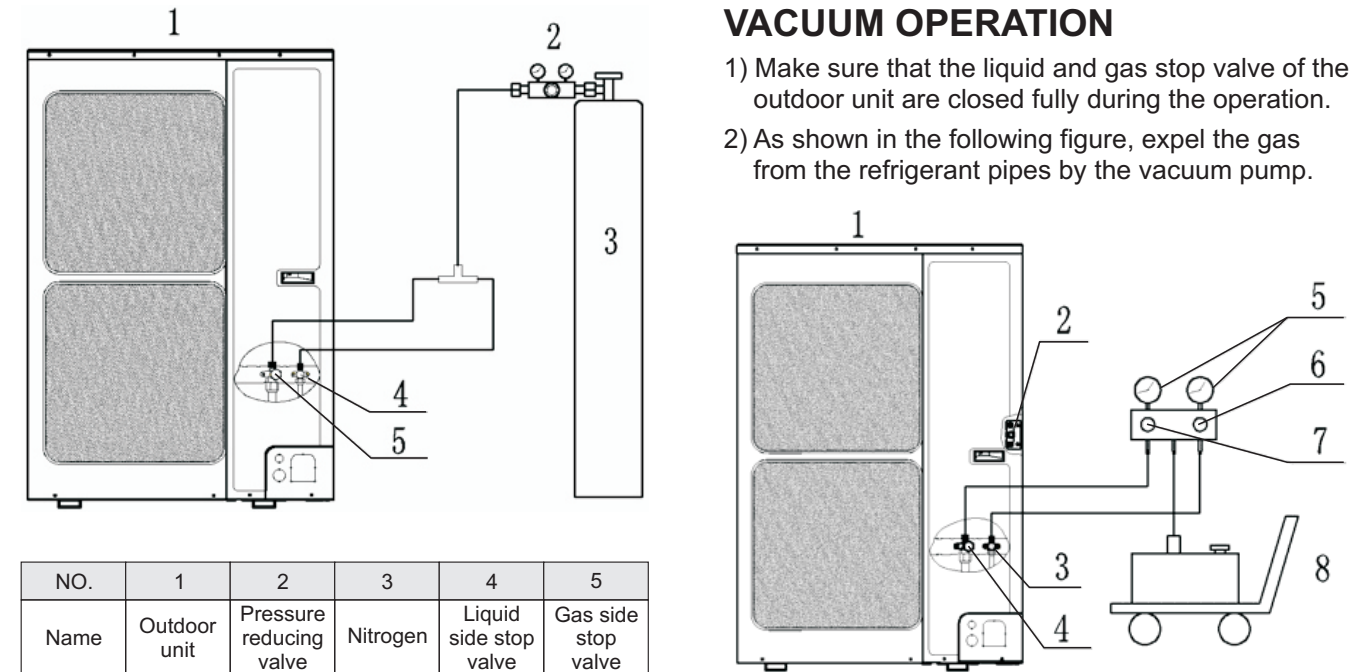

NO.	1	2	3	4	5
Name	Outdoor unit	Pressure reducing valve	Nitrogen	Liquid side stop valve	Gas side stop valve

- 3) Open the pump and turn on the knobs to evacuate the gas in the liquid and gas pipes.
- 4) When the pressure of the system is less than -0.1Mpa (-1bar), keep the system for more than one hour under the condition.
- 5) Then turn off the knobs and the pump, and if the pressure of the pressure-vacuum gauge does not rise within 2 hours, the system is under a vacuum. Otherwise, the system has leaked, please look for where the gas leaks in.

REFRIGERANT CHARGING

The refrigerant has been charged into the outdoor unit before shipped from the manufacturer, while additional refrigerant still need be charged into the refrigerant pipe during the field installation.

Calculation of the Additional Refrigerant Charging

Note:

- * The refrigerant charge of the outdoor unit does not include the charged additionally in the indoor unit, BU module and the refrigerant pipe.
- * For the length of the connecting pipe is decided on the field, the amount of additional refrigerant shall be decided depending on the dimension and the length of the liquid pipe used on the field.
- * Record the additional refrigerant charge for future maintenance.
- * It does not need to add refrigerant if the total length of liquid pipe is within 30m.

Example: WMMS-90CH-V2B(59) (2)

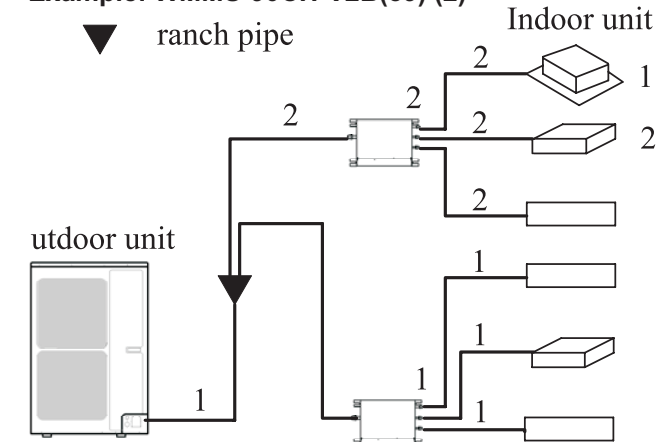

Serial No.	Model	
Indoor unit 1	Cassette type	WMMS-12EC-V2B(59)2
Indoor unit 2	Duct type	WMMS-12EF-V2B(59)2
Indoor unit 3	Wall mounted type	WMMS-18EW-V2B(59)2
Indoor unit 4	Wall mounted type	WMMS-09EW-V2B(59)2
Indoor unit 5	Ceiling/Floor	WMMS-12EU-V2B(59)2
Indoor unit 6	Wall mounted type	WMMS-09EW-V2B(59)2

INSTALLATION OF REFRIGERANT PIPES

Serial No.	Diameter (inch)	Length (m)
L1	0.375	20
L2	0.375	10
L4	0.375	10
1A	0.25	5

1B	0.25	5
1C	0.25	5
2A	0.25	5
2B	0.25	5
2C	0.25	5

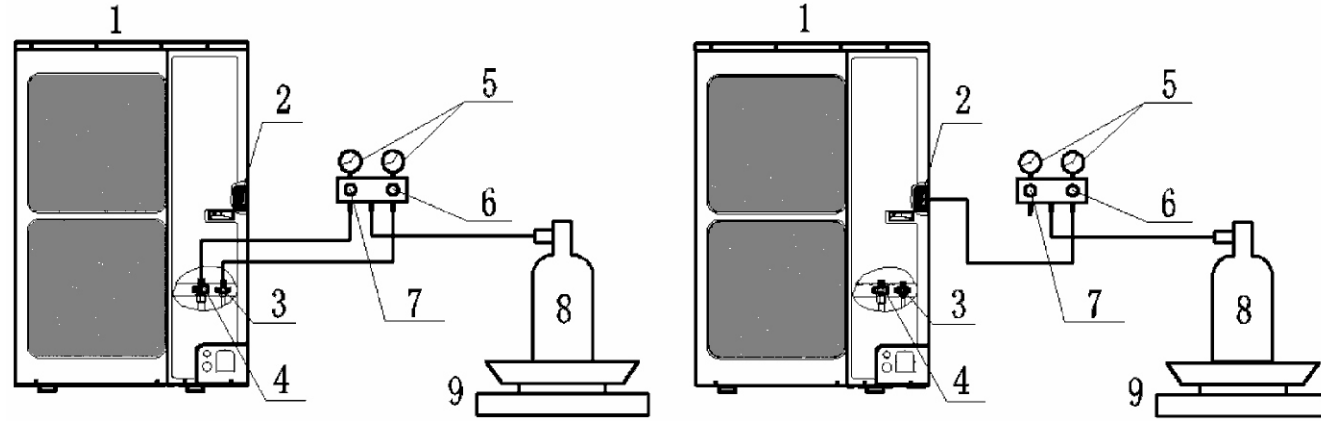

NO.	1	2	3	4	5	6	7	8	9
Name	Outdoor unit	Service port	Liquid side stop valve	Gas side stop valve	Pressure-vacuum gauge	Hi-knob	Lo-knob	R410A tank	Scale

When the liquid and gas stop valves have not been opened, the system is under the vacuum:

- 1) Refer to the left of the Fig. 20, connect the R410A tank to the system.
- 2) Turn on the R410A tank and the Hi-knob, charge the R410A refrigerant into the system from the liquid side stop valve. The Lo-knob should be closed completely.
- 3) Turn off the R410A tank and the Hi-knob immediately, when the adding refrigerant is enough.
- 4) Turn on the liquid and gas side stop valves in an anticlockwise direction slowly and completely.

If the pressure of the system is too high to charge refrigerant, you can do as follow:

- 1) Turn on the liquid and gas side stop valves in an anticlockwise direction slowly and completely.
- 2) Turn on the power of the air conditioner, and set cooling mode, running more than 0.5h when outside temperature is higher than 59°F DB.
 - a) Refer to the left of the Fig. 20, connect the R410A tank to the system.
 - b) Turn on the R410A tank and the Lo-knob, charge the R410A refrigerant into the system from the gas side stop valve. The Hi-knob should be closed completely.
 - c) Turn off the R410A tank and the Lo-knob immediately, when adding refrigerant is enough.
- 3) Turn on the power of the air conditioner, and set heating mode, running more than 0.5h when outside temperature is lower than 59°F DB.
 - a) Refer to the right of the Fig. 20, connect the R410A tank to the system.
 - b) Turn on the R410A tank and the Hi-knob, charge the R410A refrigerant into the system from service port. The Lo-knob should be closed completely.
 - c) Turn off the R410A tank and the Hi-knob immediately, when adding refrigerant is enough.

- * Make sure the liquid and gas side stop valves are opened completely after the installation.
- * Make sure exact refrigerant charge for the liquid pipe
- * Additional refrigerant charge must be measured exactly.
- * Make sure charging the liquid refrigerant into the system.
- * Please prevent the refrigerant leakage from your body when removing charging hose.
- * Please heat the refrigerant tank with hot water or hot air when the outside temperature is too low. However, it must be forbidden to heat with fire directly, otherwise it may lead to explosion.

ELECTRICAL WIRING WORK

WIRING CONNECTION

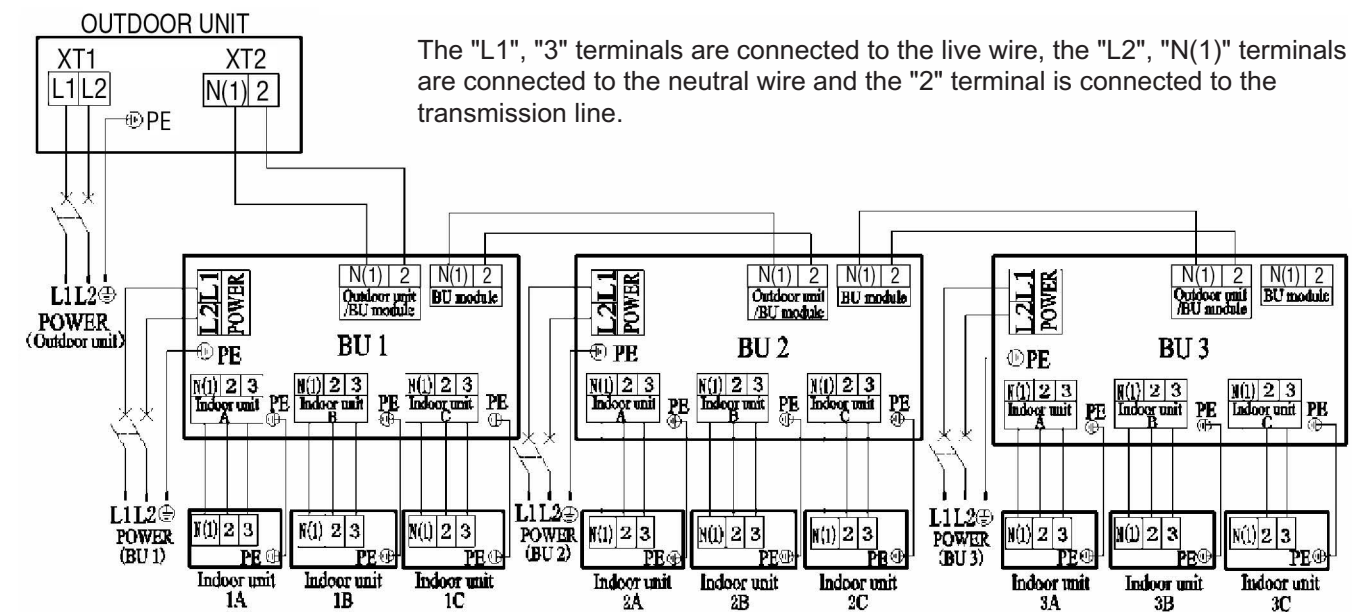

The "L1", "3" terminals are connected to the live wire, the "L2", "N(1)" terminals are connected to the neutral wire and the "2" terminal is connected to the transmission line.

REQUIREMENTS OF POWER CIRCUIT AND CABLE

Equipment	Model	Power Supply, if ODU Separately from Branch Boxes/IDUs				Power Supply, first ODU and then to Branch Boxes/IDUs			
		V/Ph/Hz	Circuit Breaker	Line AWG	Ground AWG	V/Ph/Hz	Circuit Breaker	Line AWG	Ground AWG
Outdoor Unit (ODU)	WMMS-80CH-V2B(59)2	208-230/1/60	40AMP	>=8	>=12	208-230/1/60	50AMP	>=6	>=10
	WMMS-90CH-V2B(59)2		50AMP	>=8	>=12		60AMP	>=6	>=10
Branch Unit Box (BU)	1-2S	208-230/1/60	15, if by itself	>=14	>=16	208-230/1/60	NA	NA	NA
	1-3S		15, if by itself	>=14	>=16		NA	NA	NA
	1-5S		20, if by itself	>=12	>=14		NA	NA	NA
Indoor Units (IDU)	Up to 5 from Each Branch Box	N(1)2/3/G from Branch Box	NA	>=18	>=18	N(1)2/3/G from Branch Box	NA	>=18	>=18

Note:

- * The total length of the transmission line between the outdoor unit and the furthest BU module is not more than 180ft. Otherwise, the system will not work possibility.
- * The specifications of the power cable and transmission line listed in the table above are determined based on the maximum power (maximum amps) of the unit.
- * The specifications of the power cable listed in the table above are applied to the conduit-guarded multi-wire copper cable (like, YJV copper cable, consisting of PE insulated wires and a PVC cable jacket) used at 104°F and resistible to 194°F. If the working condition changes, they should be modified according to the related national standard.
- * The specifications of the air switch listed in the table above are applied to the breaker with the working temperature at 104°F. If the working condition changes, they should be modified according to the related national standard.
- * The length of the recommended power cable should be less than 15 meters; otherwise, the diameter of the power cable is not enough.
- * Mentioned power cable and transmission line length is just a reference value. It may be different depending on the condition of installation, humidity or materials, etc.

GROUND REQUIREMENTS

- * The air conditioner is classified as a Class I appliances, so its ground ways must be reliable.
- * The ground wire must be fixed on the screw hole with the sign as the right figure.

ELECTRICAL WIRING WORK

- * The yellow-green wire of the air conditioner is the ground wire and must be fixed by the tapping screw. And it cannot be used for other purpose or cut off. Otherwise, it will cause the hazard of electric shock.
- * The reliable ground terminal should be provided and the ground wire cannot be connected to any of the following places: a) Water pipe; b) Coal gas pipe; c) Sewage pipe; d) Lightning rod; e) Telephone line; f) Other unreliable places considered by a professional.

PRECAUTIONS ON THE ELECTRICAL WIRING WORK

- * The ground connection should be reliable and the ground wire should be connected to the dedicated device of the building by the professional.
- * The electric installation should be carried out by the professional as instructed by the local laws, regulations and also this manual.
- * The air switch coupled with the leakage current protection switch must be equipped in the circuits, which is of enough capacity and of both magnetic and thermal tripping functions in case of the short circuit and overload.
- * The power supply of the outdoor unit and all the BU modules should be separately.
- * The electrical work should use a cable length enough to cover the entire distance with no connection. If it is unavoidable, please make sure the connection should be reliable and the external forces will not act on the wires. Otherwise it will cause electrical shock or fire etc.
- * The power cable with the rated voltage and exclusive circuit for the air conditioning should be used.
- * Do not pull the power cable by force.
- * The diameter of the power cable should be large enough and once it is damaged, it must be replaced by the dedicated one.

PRECAUTION OF LAYING WIRES

- 1) Use a wire stripper to strip off about 0.1inch of the insulation layer at the end of the wires;
- 2) Loosen the screws on the terminal block of the air conditioner;
- 3) Use the pliers to bend the end of the wire into a ring shape corresponding the size of the screw;
- 4) Pass the screw through the wire ring and fix it onto the terminal block.

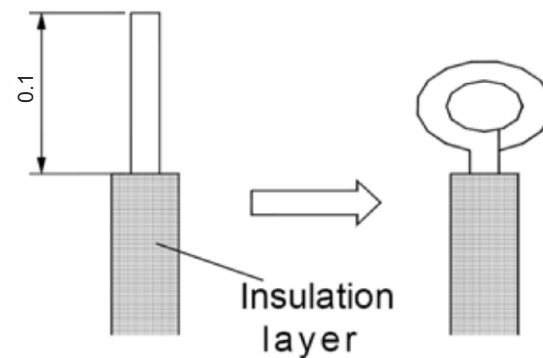

PROCEDURES FOR ELECTRICAL WIRING WORK

- 1) Knock the holes in the plate of the chosen direction with the hammer.
 - 2) Place the rubber ring on the knockout hole.
 - 3) Let the power cable and transmission line go through the knockout hole.
 - 4) Connect the power cable of the outdoor unit to the L1, L2 terminals with the sign of the XT1 and as well as the ground screw.
 - 5) Connect the transmission line of the outdoor unit to the N(1), 2 terminals with the sign of the XT2.
 - 6) Fix the power cable and transmission line firmly by cable fixing clip.
 - 7) Screw the coping plate, front side plate, right connection board, front connection board back.
 - 8) Cover the through-holes with sealing materials to prevent the water, dust or small animals going into the outdoor unit.
- * The transmission line and the power cable must be separated and separated with an interval of at least 2cm; otherwise it may be result in communication problem.
 - * In order to protect the power cable and transmission line from damaging by the hole, the rubber ring must be placed on the hole. Otherwise, it may cause electrical shock or fire etc.
 - * The power wire and transmission line must be more than one meter away from televisions or radios which can emit electromagnetic waves to prevent image interference or noise. Otherwise, the unit maybe cannot work.
 - * Confirm the each cable connected to the terminal screw is exactly and securely after finishing the electric work.
 - * Fix each ground wire separately with the ground screw.
 - * If the connecting wire is connected to the terminal incorrectly, the unit will not work normally.

DESIGN OF DRAINAGE PIPELINE

INSTALLATION OF DRAIN HOSE

- 1) Choose one drain hole in the bottom of the outdoor unit.
- 2) Connect the drain hose to the drain hole.
- 3) The drain hose should be kept at 5~10 degrees of gradient to facilitate discharge of the condensing water. Take care that does not exert too much force on the hose.
- 4) Thermal insulation materials should be placed at the joints of the drain hose so as to prevent from dew condensation. Fix the drain hose firmly by binding band.
- 5) The end of the drain hose should be inserted into the hole of drainage pipeline.

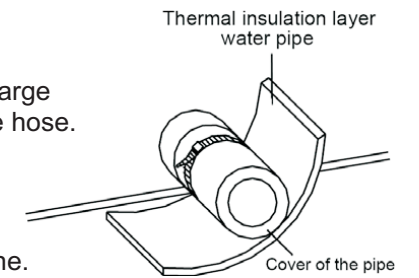

DESIGN OF DRAINAGE PIPELINE

- 1) The drainage pipeline should be kept at a certain gradient (1/50~1/100) so as to avoid bulges of pipes where there might be water bends.
- 2) The drainage pipeline is form of the hard PVC pipes for common purposes which can be purchased locally. The diameter of the PVC pipes is not less than 31mm and the pipeline should be fixed as close to the BU module as possible.
- 3) Insert the drain hose into the drain hole of drainage pipeline. Use binding band to fix it tightly. It is not allowed to use adhesive glue to join the drain hose to the drainage hole.
- 4) When the drainage pipeline is laid for a couple of units, the position of the shared pipeline should be approximately 3.94inch lower than the drainage hole of each module. In this case, some special-purpose pipes with thicker walls will be used.
- 5) At intervals of about 1 meter, fix the drain pipes to the wall with brackets, not floating in the air.

INSTALLATION OF PROTECTIVE LAYER ON CONNECTION PIPE

- 1) The refrigerant pipes should be insulated by the insulating material and plastic tape in order to prevent water condensation and leakage.
- 2) Do not use the foam on the branch pipe as the material for heat insulation.
- 3) The joints of the system should be wrapped with the insulating material and no gap is allowed on the joint of the system, as shown in Fig.24.
- 4) Bundle the refrigerant pipe and transmission line together with tape, and separate them from the drain pipe to prevent the condensate water overflowing.
- 5) Wrap the pipe from the bottom of the outdoor unit to the top of the pipe where it enters the wall. During the wrapping, the later circle should cover half of the former one.
- 6) At intervals of about 1 m eter, fix the refrigerant pipes to the wall with brackets, that is, don't let the unit withstand the weight of it or float it in the air.

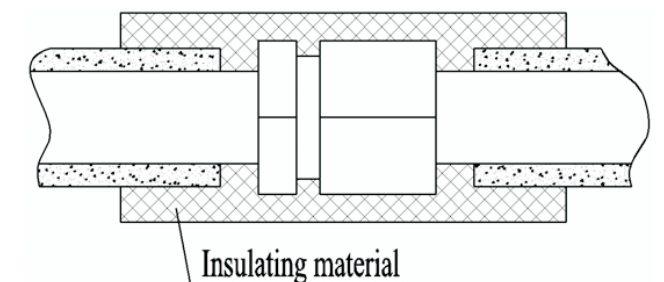

- * After the pipe is protected well enough, never bend it to form a small angle(<math><90^\circ</math>), otherwise it would crack or break.
- * Do not wrap the refrigerant pipes very tight, otherwise the insulation effect would be weakened. Additionally, make sure the drain hose is separated from the refrigerant pipes.
- * After that, cover the hole on the wall with sealing materials to prevent wind and noise going into the room.

TEST OPERATION

CHECK AFTER INSTALLATION

Items to be checked	Possible malfunction
Has it been fixed reliable?	The unit may drop, vibrate or make noise.
Has the gas leakage been checked?	It may cause insufficient cooling(heating) capacity.
Is the thermal insulation of the unit sufficient?	It may cause condensation and dripping.
Is the drainage well?	It may cause condensation and dripping.
Is the voltage in accordance with the rated voltage marked on the nameplate?	It may cause electric malfunction or the components may be burned out.
Are the lines and pipelines correctly installed?	It may cause electric malfunction or the components may be burned out.
Has the unit been safely grounded?	It may cause electrical leakage.
Are the models of lines in conformity with requirements?	It may cause electric malfunction or the components may be burned out.
Are there any obstacles near the air inlet and outlet of the indoor and outdoor units?	It may cause insufficient cooling(heating) capacity.
Have the length of connection pipes and refrigerant charge amount been recorded?	It is not easy to decide the charge amount of refrigerant.

TEST OPERATION

1) Before test operation

- * The appearance of the unit and the refrigerant pipes cannot be damaged during the installation.
- * Do not switch on power before installation is complete.
- * Electrical wiring must be connected correctly and securely.
- * The stop valves of the outdoor unit should be opened fully.
- * All the debris such as scraps and thrums must be cleared from the unit.

2) Test operation method

- * Test operation should be carried out by the licensed professional personnel while on the premises so that all items listed above are in normal conditions.
- * Set the status of the power supply switch as "ON" eight hours before the start of operation
- * Press mode button, to select the COOL, HEAT, FAN. Whether the air conditioner will work normally or not.
- * The fan motor of the indoor unit will run automatically in one minute.
- * The fan motor and compressor of the outdoor unit will run automatically in one minute.

If the unit cannot work or has any abnormal noise after the compressor is started, turn off the unit for an immediate check.

TESTING BOARD INTRODUCTION

COMPOSE OF THE TESTING BOARD

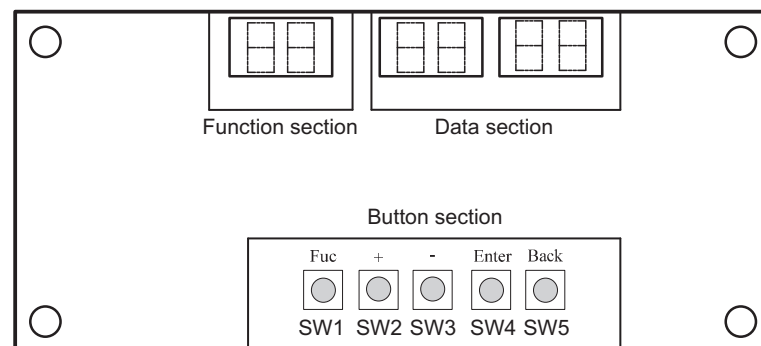

The testing board is composed of the function section, data section and button section.

TESTING BOARD INTRODUCTION

INSTRUCTION OF FUNCTION AND DATA SECTION

Running state	The display of function section				The display of data section	
Stop	1) The section will display the numbers of the indoor units which have established communication with the outdoor unit. For example, if there are seven established indoor units, the section will display "7". 2) It will display the address of the indoor units by turns. For example, the "1b" is represented of the indoor unit 1B. (BU module: 1/2/3/4, Indoor unit: A/B/C)				1) If the function section displays the numbers of the indoor units, the data section will display the outside temperature. For example, the "35" is represented of 95°F. 2) If the function section displays the address of the indoor unit, the data section will display the capacity of the indoor unit, for example, the "35" is represented of 3500W.	
Normal	The code of running state:					
	Code	Running state	Code	Running state	It displays the target gear of the compressor. If the gear is zero, it will display "0". For example, the gear is the fifteenth; it will display "15". The range of the gear is from 0 to 60.	
	UE	Pressure equalization	UH	Heating		
	UP	Pump down	F7	Oil returning		
UC	Cooling	H1	Defrosting			
Malfunction	If the malfunction occurs in the system, the section will display the error code. If there are several malfunctions, it will display the error codes by turns at intervals of 2 seconds.				1) If the malfunction occurs in the outdoor unit, the section displays nothing; 2) If the malfunction occurs in the indoor units, the section displays the address of the indoor unit.	

TROUBLESHOOTING

- * In the event of abnormal conditions (like, stinky smell), please shut off the power supply immediately and then contact the appointed service center; otherwise, the abnormal running would damage the air conditioner and also would cause electric shock or fire hazard.
- * Do not repair the air conditioning personally but instead contact the professionally skilled personnel at the appointed service center, as the incorrect repair would cause electric shock or fire hazard etc.

CHECK BEFORE CONTACTING SERVICE CENTER

Please check the following items before contacting the maintenance serviceman.

Conditions	Causes	Corrective actions
The unit does not run at all	Broken fuse or breaker is off	Replace the damaged fuse or close the breaker
	Power off	Restart the unit after power supply resumes
	Power supply plug is loose	Plug the power supply properly
	The batteries voltage of the remote controller is insufficient	Replace with new batteries
	Remote controller is out of the control scope	The distance shall be within 8m
The unit stops soon after it starts	Air inlet or outlet of indoor unit or outdoor unit is blocked	Remove the obstacles
Cooling or heating is abnormal	Air inlet or outlet of indoor unit or outdoor unit is blocked	Remove the obstacles
	Temperature setting is improper	Adjust the setting of remote controller or wire controller
	Air speed is set too low	Adjust the setting of remote controller or wire controller
	Improper airflow direction	Adjust the setting of remote controller or wire controller
	Door or window is open	Close the door or window
	Under direct sunshine	Hang curtain or blinders over the window
	Too many people in the room	
	Too many heat sources indoors	Reduce the heat sources
The filter screen is dirt or blocked	Clean the filter screen	

If the air conditioner still runs abnormally after the above check and handling, please contact the local appointed service center and also give a description of the error occurred as well as the model of the unit.

TROUBLESHOOTING

PROBLEM HANDLING

The conditions listed below are not classified into errors.

Conditions		Causes
The unit does not run	When restart the unit soon after it is stopped	The overload protection switch of the unit let the startup delayed for three minutes
	As soon as power supply is on	The unit will stand by for approximate one minute
The unit blows out mist	When the cooling operation starts	The hi-humidity air indoor is cooled quickly
The unit generates noise	The unit "clatters" as soon as it starts running	It is the sound generated during the initialization of the electronic expansion valve
	The unit "swishes" during the cooling operation	It is the sound when the refrigerant gas runs inside the unit
	The unit "swishes" when it is started or stopped	It is the sound when the refrigerant gas stops running
	The unit "swishes" when it is in and after the running	It is the sound when the draining system is operating
	The unit "squeaks" when it is in and after the running	It is the sound of friction generated by the skin plate etc which swells due to the temperature change
The unit blows out dust	When the unit restarts after it is not used for a long time	The dust inside the unit is blown out again
The unit emits odors	When the unit is running	The odors absorbed in are blown out

ERROR DESCRIPTION

If some error occurs when the unit is running, the error code will be displayed on the wired controller, the main board and the testing board of the outdoor unit. Check for more details about the meaning of each error.

Errors of definition	Main control display for outdoor unit			Indoor unit code	Testing board code
	Yellow LED	Red LED	Green LED		
The compressor is startup	Flash 1 time				
IPM current protection	Flash 3 times			H5	H5
IPM temperature protection	Flash 5 times			P8	P8
PFC current protection	Flash 7 times			HC	HC
PFC temperature protection	Flash 8 times			P8	P8
Low voltage protection	Flash 9 times			PL	PL
High voltage protection	Flash 10 times			PH	PH
Low pressure protection	Flash 11 times			E3	E3
High pressure protection	Flash 12 times			E8	E8
High pressure switch protection	Flash 13 times			E1	E1
Capacitor charging error	Flash 14 times			PU	PU
Current protection	Flash 15 times			E5	E5
Memory card error	Flash 16 times			EE	EE
Compressor demagnetizing protection	Flash 17 times			HE	HE
Compressor desynchronizing	Flash 18 times			H7	H7
Compressor phase lack	Flash 19 times			U2	U2
Compressor phase circuit detection error	Flash 20 times			U1	U1
Compressor current protection	Flash 21 times			L9	L9
Compressor overload protection	Flash 22 times			H3	H3
Compressor discharge temperature protection	Flash 23 times			E4	E4
Lack of refrigerant or jam protection	Flash 31 times			F0	F0
Normal operation		Flash 1 time			
Frequency limitation for current protection		Flash 2 times			F8
Oil returning		Flash 3 times		F7	F7
Defrosting		Flash 4 times		H1	H1
Frequency limitation for IPM temperature protection		Flash 5 times		EU	EU

TROUBLESHOOTING

Frequency limitation for PFC temperature protection		Flash 6 times		EU	EU
Frequency limitation for compressor overload protection		Flash 8 times			LU
Frequency limitation for compressor discharge temp protection		Flash 9 times			F9
Frequency limitation for low pressure protection		Flash 10 times			Pn
Frequency limitation for high pressure protection		Flash 11 times		F6	F6
Discharge temperature sensor error		Flash 12 times		F5	F5
Outside temperature sensor error		Flash 13 times		F3	F3
Suction temperature sensor error		Flash 15 times			dc
Condenser temperature sensor error		Flash 16 times		A7	A7
Sub-cool temperature sensor error		Flash 17 times			bC
Low pressure sensor error		Flash 18 times			dL
High pressure sensor error		Flash 19 times			e1
Fan motor protection		Flash 20 times		H6	H6
Driving board is connected			Flash 1 time		
Testing board is connected			Flash 2 times		
Computer is connected			Flash 4 times		
Indoor unit 1 is connected			Flash 5 times		
Indoor unit 2 is connected			Flash 6 times		
Indoor unit 3 is connected			Flash 7 times		
Indoor unit 4 is connected			Flash 8 times		
Indoor unit 5 is connected			Flash 9 times		
Indoor unit 6 is connected			Flash 10 times		
Indoor unit 7 is connected			Flash 11 times		
Indoor unit 8 is connected			Flash 12 times		
Indoor unit 9 is connected			Flash 13 times		
Indoor anti-freeze protection				E2	E2
Inside temperature sensor error				F1	F1
Evaporator midway temp sensor error				F2	F2
Liquid pipe of BU module temperature sensor error				b5	b5
Gas pipe of BU module temperature sensor error				b7	b7
Mode conflicts				E7	E7
Communication error	BU 1	Indoor unit A			E6 1A
		Indoor unit B			E6 1B
		Indoor unit C			E6 1C
	BU 2	Indoor unit A			E6 2A
		Indoor unit B			E6 2B
		Indoor unit C			E6 2C
	BU 3	Indoor unit A			E6 3A
		Indoor unit B			E6 3B
		Indoor unit C			E6 3C
	BU 4	Indoor unit A			E6 4A
		Indoor unit B			E6 4B
		Indoor unit C			E6 4C
Communication error between the main board and driving board					P6
Communication error between the main board and testing board					CE
Indoor unit gas sensor error					Fn
Indoor unit humidity sensor error					L1
Indoor unit water full error					E9
Jumper terminal error				C5	C5
Refrigerant recovery mode				Fo	Fo

CUSTOMER AND TECHNICIAN MUST READ

WHY DOES YMGI GROUP REQUIRE INSTALLATION AND SERVICE TO BE 100% PERFORMED BY LICENSED OR CERTIFIED HVAC TECHNICIAN/ CONTRACTOR?

1) They have the training and experience to accurately and safely install and service your equipment.

The equipment runs with high-pressure refrigerant and oil and line-voltage. The copper lines must be installed properly to prevent leakage and foreign substances from contaminating the refrigerant system.

2) You will save money in the long run.

If any problems occur on the unit that is fully installed by the licensed or certified contractor, they have the training and experience to correct the problem more efficiently. A technician(s) may be unwilling to repair an issue on a unit that they did not install. If you do find a technician willing to perform the service, there is an increased possibility of higher service fees than normal, increased service visits, or delayed service from that technician.

3) It's the law!

The federal, state and/or local government and authorities have various governing laws or regulations, guidelines, ordinances, etc., requiring only licensed or certified professionals can install and service high pressure HVAC equipment.

SUGGESTIONS, TO AID YOU IN HIRING AN HVAC CONTRACTOR:

- 1) Hire a currently, practicing, licensed/ certified HVAC technician/ contractor. Technicians, who are no longer practicing (retired, etc.) in this field, may not have the updated knowledge or may lack experience on the equipment you have purchased.
- 2) Hire a technician/ contractor who services customers in your local area and you are familiar with. Local contractors have a faster response time and will be easier for you to determine if they are reputable.
- 3) Use only reputable licensed/ certified HVAC installation contractors/ technicians to prevent any unexpected charges as a result from unethical business practices.
- 4) Check their references, to verify they are a good service provider to the general customers. N.A.T.E or A.C.C.A certified technicians are strongly recommended.
- 5) Some contractors/ technicians may not feel comfortable about installing the equipment that you purchased for them to install, and they prefer to purchase and install the equipment. You can contact YMGI directly to check and see if there have been any contractors in your area who have installed our products or similar.
- 6) Ask for a detailed quote for the whole installation project. A flat rate quote is the safest contract for both you and the contractor
- 7) Your local HVAC technicians may charge you on a project basis or on an hourly basis. To our general knowledge and experience, **a full single head installation may normally cost anywhere from \$800 to \$1500.** These costs are estimates and your actual costs may differ due to job nature and location.
- 8) Number of hours can vary depending upon each individual situation, some factors are, but not limited to:
- 9) How difficult or complex the indoor unit is to be securely installed.
- 10) How difficult or how long the inter-connecting pipes and wires are to be installed.

CUSTOMER AND TECHNICIAN MUST READ

- 11) If all the suggestions have been taken and all the necessary steps are followed.
- 12) If the contractor(s)/technician(s) are experienced with the systems/brands you purchase.
You might spend less. But remember, many times you get what you pay for.
- 13) Sign a contract with them. The contract should list all the detailed work they will conduct and the standards they will follow. Some contractors are willing to include a 1-year installation/service warranty at no extra charge. Check with them to see if that is available. If available, include that in the contract.
- 14) Verify and confirm the installation is done completely and all the unit functions have been checked and are working properly, all the items in the checklist have been checked and marked well in the warranty registration card/form, prior to paying the contractor in full.

The cost of not having your unit installed properly can be more expensive than spending a little extra money that hiring the right contractor will cost. Protect your investment and warranty eligibility by doing it right first time.

UPON PURCHASING, OPENING PACKING BOXES AND INSTALLATION OF YMGI UNITS/ACCESSORIES, YOU AND TECHNICIANS YOU HIRE TO INSTALL THEM ARE ASSUMED TO HAVE READ ALL MATERIALS AND AGREE TO FOLLOW AND BE BONDED BY ALL WE SAY IN YMGI MANUALS.

- 1) You understand all that is written hereafter in this and other documents that we publish.
- 2) You will follow what is written hereafter in this and other documents that we publish.
- 3) You will be bound by and completely follow all policies, guidelines, instructions, warnings, attentions and other materials, as published by YMGI Group, its subsidiaries or sister companies, in writing.
- 4) Only a successful installation, fully (100%) conducted by a qualified HVAC technician(s), as detailed in the checklist of the **Limited Product Warranty Policy** and **Limited Product Warranty Registration Card/Form**, along with a properly detailed installation invoice, is eligible for the **Limited Product Warranty**.
- 5) Failure to follow what is written hereafter may cause various equipment issues that you will take full responsibility and liability for, including, but not limited to, losing manufacturer's warranty, unit not working properly, unit malfunctions, under-performance, decreased safety, increased potential of various damages to your property, body, home and/or business, etc.
- 6) YMGI documents and policies supersede those made or provided by the sales distributors or installing contractors. YMGI Group maintains the final authority in explaining and resolving any and all discrepancies that might exist between distributors/contractors' documents and ours.

YMGI STRONGLY RECOMMENDS:

- * Customer hires a currently licensed/ certified HVAC technician(s) (N.A.T.E. or A.C.C.A certification is strongly recommended) to conduct 100% of the installation, inspection of all unit functions and repair service.
- * Customer signs an installation/service contract with the installation/service technician's company who has good service references and you trust. Installation and service is very important to the life of your investment and provide you a lifetime of comfort and peace of mind.
- * Customer requests the installer to put down a 1-year labor warranty coverage in the installation contract.
- * Have the technician check against all the items in the checklist of the **Limited Product Warranty Registration Card/Form**, sign and date it, to help ensure a proper and professional installation.
- * Customer pays in full, only after all the unit functions are inspected, the unit works properly, warranty checklist is fully filled out and signed and you are fully satisfied.
- * If any unit abnormality is found, have your technician check the unit first. Have them call for manufacturer technical assistance, if necessary, from your job site, not his office, so that we can more accurately assist him in diagnosing the cause of the malfunction.

QUESTIONS ABOUT SELF-INSTALLATION VS HIRING LICENSED HVAC TECHNICIANS

Does YMGI allow to do-it-yourself installations (DIY) partially or fully? NO.
Unfortunately no brand or manufacturer can take the responsibility of the equipment if it is not professionally installed by a currently licensed HVAC technician/ contractor.
If unit is installed by non-licensed people, in part or fully, will the factory warranty be void? YES.



CUSTOMER AND TECHNICIAN MUST READ

Some DIY installations have been successful, but these are exceptions. Most have resulted in equipment failure, due to lack of knowledge and experience. A few of the problems result from DIY's lack of knowledge in the following areas:

- * Sizing and selecting correct type, size and model of cooling and/or heating equipment.
- * Sizing and installing correct electric circuit breakers and wires.
- * Wiring the units correctly and properly.
- * Taping the ends, connecting to indoor and outdoor units correctly and properly.
- * Vacuuming the inter-connecting refrigerant lines.
- * Checking and/or fixing the refrigerant leaks.
- * Checking and/or fixing the condensate drain leaks.
- * Releasing the refrigerant from outdoor unit to indoor unit.
- * Running the unit to check all the unit functions.
- * Conducting the installation or trouble-shooting with correct tools, experience or professional knowledge to correct the problem.

RECEIVING AND FREIGHT DAMAGE

- * Freight (package/unit) shall be checked thoroughly for damage at receiving before accepting by signing on the carrier's delivery paperwork.
- * Upon shipment being signed for acceptance, it becomes a binding document as to the condition of the products on delivery. We cannot process any shipping damage claim, if you accept the delivery.
- * If damage is found at delivery, both you and the delivery driver must make notes on the delivery receipt or other freight paperwork detailing the damage found by marking position/parts on unit, description of damage, time/date, your name, contact phone, etc. on the delivery documents. Make a copy of the marked delivery receipt.
- * If the damage is minor or partial, that you choose to accept, you can contact the distributor or YMGI to discuss the possible replacement of the damaged part.
- * If refusal of the shipment is needed due to severe freight damage, **DO NOT** sign the carrier's delivery receipt document indicating that you accept the products. Mark receipt "REFUSED DUE TO FREIGHT DAMAGE." Sign and date along with the delivery driver's signature and date.
- * Take pictures showing the damage, before the delivery driver leaves.
- * If you accept the delivery or fail to note damage on the driver's delivery receipt, the ability to claim freight damage is lost and YMGI will not replace the unit on this basis.
- * Contact the distributor or YMGI, report the damage by forwarding the marked delivery receipt copy and pictures.
- * Only after YMGI verifies with the carrier the necessary detailed notes of received freight damage, will the damaged products be eligible for replacement.
- * If the returned products are found not damaged, YMGI will treat it as a return and will charge you 25% of product value plus added shipping cost.

RETURN-YMGI GROUP POLICIES & RETURN GOODS AUTHORIZATION (RGA)

All sales are final. If the customer wishes to return a product, the following **Return Policies** apply.

A. Only those products (units, parts or accessories) under the following conditions, are eligible for return:

- 1) **Products are returned within 30 days of their original shipment date from YMGI**
- 2) Products have not been installed.
- 3) No damage exists on the products being returned.
- 4) No missing products.
- 5) Products and packages are clean.
- 6) No duct tape or marking on the product or box.
- 7) Products are still their original package, in good shape and in re-sellable condition, as YMGI determines.

B. Preapproval steps for your return request:

- 1) Contact your distributor or YMGI to request a return.
- 2) Photograph your product and box to show details
- 3) YMGI will review your request, along with the pictures and any other details pertaining to your request.
- 4) If YMGI agrees to process your return request, a form called **Return Goods Authorization (RGA), along with an assigned RGA #** will be forwarded to your distributor or you.
- 5) Any return without YMGI Group approved RGA #, will not be accepted.

CUSTOMER AND TECHNICIAN MUST READ

C. YMGI must verify the following before you can pack your products:

- 1) No products (units, parts, accessories) are missing.
- 2) No damage is found.
- 3) The products are in the original packaging.
- 4) No duct tape on any product or box.
- 5) Pictures have been taken and sent to YMGI to verify the product and boxes are not damaged.
- 6) The RGA has been completed and a copy has been returned to YMGI, via email or fax.
- 7) YMGI has approved the request in writing.

D. Shipping Preparation:

- 1) Package all products in a manner in which no damage can occur to the product and secure to a pallet.
- 2) Take and forward pictures of packed pallets for YMGI to verify proper packaging and no existing damage.
- 3) Include the YMGI approved RGA# in the shipping documents.
- 4) YMGI reserves the right to approve or deny any shipments.
- 5) YMGI can arrange shipping for you, but not at YMGI's cost. If this option is chosen, a packing list and BOL will be issued to you through YMGI.
- 6) If the above option is not chosen, you will be responsible for all freight charges. YMGI will not accept any returned items COD.
- 7) Place the package in an area which is accessible to the shipping company for pickup and limits the possibility of damage to the product. Customer must be present at the time of freight pick up.

After shipping, fax the BOL to YMGI Group at 1-866-377-3355 or email to customerservice@ymgigroup.com, detailing the information of the freight company and their tracking number.

E. Freight Damage:

- 1) YMGI Group will inspect returned items
- 2) Claiming of freight damage from a customer hired carrier will be the customer's responsibility.
- 3) Claiming of freight damage from a YMGI hired carrier will be YMGI's responsibility.

F. Charges for your return:

- 1) A restocking charge of 25% creditable invoice value.
- 2) All return shipping fees.
- 3) Additional fees will be charged, if products are found to be damaged, missing or used.
- 4) YMGI will notify the distributor of the charges only after the inspection and assessment of the returned products has been completed.

Attention:

- 1) Returned products must be shipped within 7 days of YMGI's releasing of **RGA #**.
- 2) **All RGA** shipping shall be prepaid by the customer. **YMGI will not accept any COD freight.**

YMGI GROUP DISCLAIMING-1:

YMGI Group will NOT accept any return, or may not honor 100% credit for any return of Product(s)/Part(s)/Accessories, in any of the following cases:

- * Return requests made 30 or more days after the date of original sales shipping from YMGI Group warehouse.
- * Return shipment is initiated 8 days or more after the RGA is approved.
- * Returned products received not displaying an YMGI-approved valid **RGA #**.
- * Returned products received C.O.D.
- * Returned products not received in the original packaging.
- * Returned products received with non-repairable packaging, including duct tape or marks on units or carton boxes.
- * Returned products received with missing units/parts/accessories.
- * Returned products received, are found to be non-functional or damaged.

YMGI GROUP DISCLAIMING-2:

- * YMGI Group will not be responsible for any losses of returned unit(s)/part(s)/accessories in transition to YMGI Group warehouse.
- * YMGI Group RGA is valid for seven (7) days from the original issuing date. Returns will not be accepted, if shipping is made 8 or more days after the YMGI Group RGA is issued.



CUSTOMER AND TECHNICIAN MUST READ

DEFECTIVE UNITS / PARTS / ACCESSORIES-REPAIR OR REPLACEMENT

Out of thousands of units sold every year, there may be an occasional instance your product does not operate properly. Reasons of but are not limited to: **manufacturing, installation, operation, maintenance and knowledge of operator.**

Equipment failure does not automatically denote a product defect from the factory assembly line. The defects can be caused, during production, transportation, installation, operation, maintenance, or service. Defects may NOT be the responsibility of the manufacturer. Nobody willfully or intentionally produces a defective product. No determination shall be made until the technical issue(s) or the causes of the defect(s) are identified.

The defects might be found before/ during installation or in the operation of the unit. Defects can be in the form of blown fuse(s), defective control board(s), damaged remote control, loose or missing screws, etc. These defective parts can be replaced easily.

Some functions of our units are different from what are typical in traditional split type air conditioning and heat pump systems and similar systems made by other manufacturers. These are not defects. Take some time to learn the functions of your unit. We will be happy to assist you with any questions you may have concerning the functions of your new unit.

If a defect is found, whether at the original installation, or during normal operation, we will gladly help you in the following steps in sequence from 1 to 3:

1. Part repair or replacement after trouble-shooting: This is the most common and generally the easiest and most economical way for all the needed parts since the problem and all part needs can be accurately and completely identified.

* Your technician calls our technical support line, from your job site, after checking your units and getting all the information ready.

* Our technical support will go through several steps, over the phone or through email, with your technician, in order to help identify and resolve the problems. Normally wiring correction, piping correction, part repair/ replacement will resolve the problems.

* Your technician will then need to verify and confirm the problem(s) before YMGI can ship out the replacement part(s). Inaccurate or incomplete troubleshooting or part replacement will delay the repair. YMGI technical support will only speak with a licensed/certified technician in regards to the repair of your unit. In our experience this saves time and money for all parties involved.

Your technician is the only person to perform any physical checking, trouble-shooting and replacing of any defective part(s) for your units. Our factory technical support is just a help. **YMGI provides no labor warranty on the products.**

2. Unit/part repair at our workshop(s): Due to the limitations of our technical support not being at your job site, or your technician's limited experience with our product, the problem may not be resolved as quickly as would be desired. If the problem is still not resolved after attempts between your technician and our technical support, you can elect to have the unit repaired at our facility. If this step is chosen:

1) YMGI will send to you the **Customer Request to Ship Products to YMGI Service Center for Inspection and Repair, and Authorization to Charge** form.

2) You will review the form and fill all fields appropriately, sign and send back to the YMGI Group.

3) Once the form has been completed and sent back to YMGI, remove the units and ship back to YMGI.

Please make a note describing the problem and communication history, if possible. Our technicians will check the units and find the problem(s), repair the issue(s), and ship the unit back to you following the conditions set forth in the signed repair agreement. All unit removal and re-installation is done at your cost and must be done by a currently valid licensed HVAC technician.

3. Unit replacement: Only applies to those defects reported within 30 days of original purchase date and if all necessary warranty paperwork had been received and approved. This option applies only if the above steps cannot resolve the problem(s). Either indoor or outdoor unit replacement is available, based on the actual need, at YMGI's determination. ***This option shall be the last resort***, due to refrigerant and wiring considerations. All unit removal, re-installation and shipping cost are the responsibility of the customer. YMGI maintains the final authority as to unit replacement. Replacement will be made with the same model only. Alternate units will be treated as a new order.

Returning Replaced Defective Units/Parts/Accessories After Unit Repair: (Only applies to steps 1&3 above)

1) Repack the replaced unit/ part /accessory in the box which contained the replacement part.

2) Parts can be boxed for UPS, FedEx or equivalent ground service. Units shall be secured onto the skid on which the replacement was shipped after placing into the package from the replacement product.

3) Ship **all** replaced products, to YMGI-designated location. You will be charged if YMGI does not receive the replaced parts.

CUSTOMER AND TECHNICIAN MUST READ

Standard factory warranty does not cover the cost of materials and labor that are incurred at your site. There will be no cost for the replacement unit, if YMGI determines the defect is manufacturer related. Replacement will be made with the same model, only. Alternate units will be treated as a new order.

CUSTOMER SERVICE / TECHNICAL SUPPORT FROM YMGI GROUP

For questions or help with your unit, contact the original installer or service provider.

YMGI Group does not install nor physically service your unit. Your installer or service provider must check the unit prior to contacting YMGI Group from your jobsite, in order to be helped in an efficient and timely manner.

* Factory customer service at customerservice@ymgigroup.com Tel: 1-866-833-3138x704

* Factory technical support at techsp@ymgigroup.com Tel: 866-833-3138x703

* Fax: 1-866-377-3355

An "**YMGI Group Customer Service/Technical Support Daily Log Sheet**" will be filed in writing at our office, for effective communication between you and YMGI Group customer service, your technician and YMGI Group technical support. Before contacting the YMGI Group locate the IP# written at the top of your warranty registration form. Use this IP# whenever you contact the YMGI Group.

DISTRIBUTOR AND MANUFACTURER POLICIES

* All questions concerning sales or money will be directed to the sales distributor from which you purchased the units.

* Read and follow all policies set forth from the distributor from which you purchased your unit.

* Upon purchase and installation of the unit(s), you agree to be bounded by all policies published by both distributors and YMGI.

* YMGI Group has the final authority and supersedes other related parties (distributors, etc.) concerning all policies regarding YMGI products.

YMGI DISCLAIMING-3 (RE: LIMITED PRODUCT WARRANTY)

1) The YMGI **Limited Product Warranty Policy**, details the eligibilities, coverage's and other explanations of the warranty terms between YMGI group and the unit owner.

2) The YMGI **Limited Product Warranty Policy** and the **Warranty Registration Card/Form** are either included inside the user's manual and/or installation instruction manual, or come separately in the unit packaging box/ envelope. If for any reason they are not included with your shipment, contact our sales or customer service to request a copy (electronic or printed), prior to installation.

3) The checklist, in the **Warranty Registration Card/Form**, is for the currently licensed/ certified HVAC technician to fill out completely, while verifying all unit functions are operating correctly. This checklist is for the technician to test and check all details of your unit, to verify and ensure its proper operation.

4) The technician must complete all fields in the **Warranty Registration Card/Form**, especially the unit model and serial numbers and distributor information, and most importantly, the technician checklist.

5) **Warranty Registration Card/Form** shall be mailed, **along with the original copy of the currently licensed HVAC contractor's full installation invoice**, to YMGI Group, within 7-days after original installation, in order for YMGI to review and process your warranty registration.

6) Keep a copy of **Warranty Registration Card/Form** for your own use in the future, to aid in any possible future warranty claiming, any request of parts, customer service, and/or technical support.

7) YMGI reserves the right to approve or deny the warranty status based on the information reviewed.

Mailing address of the **Warranty Registration Card/Form**: Warranty Department, YMGI Group, POB 1559, O'Fallon, MO 63366, USA.



USER NOTES AND INSTALLATION/SERVICE/MAINTENANCE NOTES

USER NOTES

Put down whatever questions you have or problems you have seen as a unit history:

No.	Date	Notes	Asked for Your Technician for Help?	Did You Ask YMGI Tech. for Help?

INSTALLATION NOTES

Put down whatever questions you have or problems you have seen as a unit history:

No.	Date	Original Installation Company Name, Technician Name, Phone & HVAC License #	Job Not Performed by Technician	Technician Checklist Completed Fully?

SERVICE / MAINTENANCE NOTES

No.	Date	Contents of Service / Maintenance	Technician's Company Name, Technician Name, Phone & HVAC License #

MEMO

